

SCADA System for Monitoring Water Supply Network: A Case Study

Cveta Martinovska Bande¹; Gjorgji Bande²

Computer Science Faculty, University Goce Delcev, Macedonia¹; ROING²

cveta.martinovska@ugd.edu.mk¹; gjorgji.bande@gmail.com²

ABSTRACT

This paper presents a case study of a SCADA system for monitoring and control of the parameters in water supply system. The system maintains functional parameters and performs continuous supervision of water distribution stations in order to allow any problem to be solved. The control system is organized in a hierarchical structure with three layers. The first layer consists of field instruments, remote terminal units and field control devices. The signals from instruments via transmitters are sent to dedicated PLC panels at the second layer. The SCADA central level contains high speed PC computers for the supervision or operative drive of remote processes. The proposed system allows optimal functioning of the pumping systems, safety of the equipment and installations and efficient water usage.

Keywords: SCADA, water supply system, data acquisition, monitoring, PLC.

1. INTRODUCTION

In literature a distinction is made between different Industrial Control Systems (ICT): Supervisory Control and Data Acquisition (SCADA), Distributed Control Systems (DCS) and Programmable Logic Controllers (PLC) [1]. SCADA systems are used for real-time acquisition of sensor data, monitoring equipment and controlling processes in water distribution and wastewater collection systems, oil and gas pipelines, electrical power grid, etc [2, 3]. DCS are used to control production systems, while PLC for regulatory control. Within the last decade the security of the SCADA systems become important concern [4]. Initially, these control systems were isolated, using specialized hardware, software and protocols. Adopting information technology (IT)

solutions for ICT, standard computers, low-cost Internet Protocol devices and network protocols contributed to connectivity and remote access capabilities. However, connecting the ICT systems to IT networks made them more vulnerable.

Modern Water Supply System (WSS) requires control, analysis and prompt response to events that reduce the effectiveness of the water supply or disrupt the functionality of the system. The technological advances in the field impose automated approach to solving these problems [5].

This paper presents a study for reconstruction of the water supply network in a small city located in eastern Macedonia. Our aim is to create a SCADA system establishing a complete monitoring of the water supply network and thus allowing for quick and effective responses to alarming situations. The WSS for this city is interesting because there are three water sources which allow different configurations of the network. The main water sources for the city are springs in Kalin Kamen and alternative water supply options are Stanechka reka and four wells in the basin of Kriva reka. Furthermore, the disposition of the WSS is set on the both banks of the Kriva Reka, each of the banks having high and low zones, with seasonal and daily variations of the water requirements.

In this paper we propose architecture of a SCADA system for monitoring and control of the parameters in the WSS which will provide adequate functioning of the WSS, safety and efficient energy usage. SCADA system provides simple, fast and effective way of dealing with some situations and difficulties, such as natural disasters and their consequences, mechanical damages to the system, water loss, power interruption and communication problems among SCADA

components. Also this system enables efficient management of the values for previously defined variables, like pressure, water flow, level of water in reservoirs etc. Finally, it is helpful for preventing bio/chemical changes, such as increased presence of chlorine or other harmful materials in the water.

2. STRUCTURE OF THE WATER SUPPLY SYSTEM

The water supply system in the analyzed town relies on the intakes of water from the area called Kalin Kamen which is located about 20 km from the city [6]. From Kalin Kamen through a pipeline the water is carried to the spillway Crvena niva (Fig. 1).

From that storage the water is distributed to the tank Baglak 3, located at the high area of the Kriva

reka right bank, and to the water fabrication plant. At the plant there is a water tank of 150 m³ and the distribution shaft. Part of the water supply system is still under construction: the inflow of Stanechka reka that serves as a supplement to the WSS, the water supply line for high zone on the left bank of Kriva reka and the reservoir of 350 m³ in district Martinica.

From the water fabrication plant the WSS continues to the chlorine station and the two main water tanks as well as to the distribution shaft used for water supplying of the low zone of the Kriva Reka, left and right bank. An additional spare water source from the wells in the region of Kriva reka is connected at the chlorine station. The water from these wells is pumped with pumps from 635 m asl to the chlorine station.

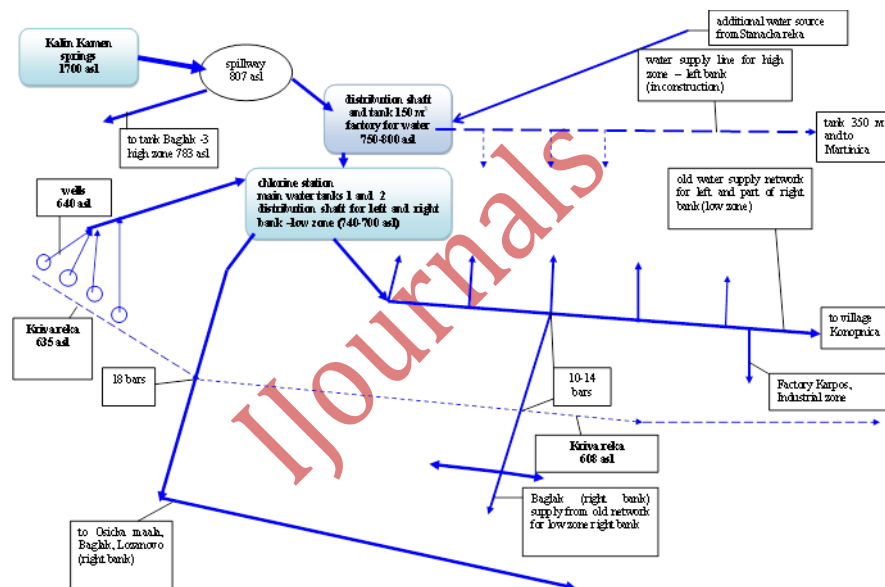

Fig 1: Global scheme of the analyzed water supply system

The two main tanks of 250 m³ are used for the low zones of Kriva reka left and right bank. Currently, the high zone of Kriva reka left bank, the industrial zone and the village Konopnica are also supplied with water from these two main tanks.

The rapid populating of the high zones of the city caused problems with the water supply and also led to defects and failures in the city network, resulting with restrictions in the water supply, particularly in the high areas. Also, there are periods when due to irrigation in the lower parts or even during the peak

of water consumption the water cannot reach the high areas. To overcome these problems and to bring the water in the higher parts, higher water pressure is used in the lower parts of the system which causes huge losses within the system.

The permanent water shortage and the returning of water from the higher parts, because of the high pressure, causes creation of so-called "air bags". This is the reason for the white color of the water, which creates an image of poor quality. Consumers believe that the water is too chlorinated because of

the coloration and this affects the water consumption. The changes of the pressure in the network cause frequent failures.

3. DESIGN AND SPECIFICATIONS

In the first stage the SCADA system comprises monitoring, alarming and reporting functions for WSS, like monitoring the levels in reservoirs, flows and pressures on the outlets of production pump stations and water distribution reservoirs, control of the chlorinating process etc. The second stage will comprise manual/automatic operation of the WSS.

The control system is organized in a hierarchical structure with three layers. The first layer consists of field instruments, remote terminal units (RTU), field control devices and control wiring (Fig. 2). Field instruments, such as electromagnetic flow meters, ultrasonic level meters, actuators and flow, level, pressure, torque and limit switches are located at the measuring points on pipelines, water channels, tanks and pump station. The signals from

instruments via transmitters are sent to dedicated PLC panels at the second layer (Fig. 3). The operators can monitor the process at the PLC display and set or adjust the process parameters according to the process conditions at the moment.

RTUs are used for monitoring the water level of the remote reservoirs/tanks. Programmable data loggers with small capacity are used as RTUs. Analog or digital data are logged and send by radio/ WiFi network to PLC panels or SCADA center. Four types of field control devices are used: electrical motors, open/close control valves, automatic control valves and chlorine dosing equipment.

The SCADA center is equipped with at least two servers, operator working station, and engineers workplace.

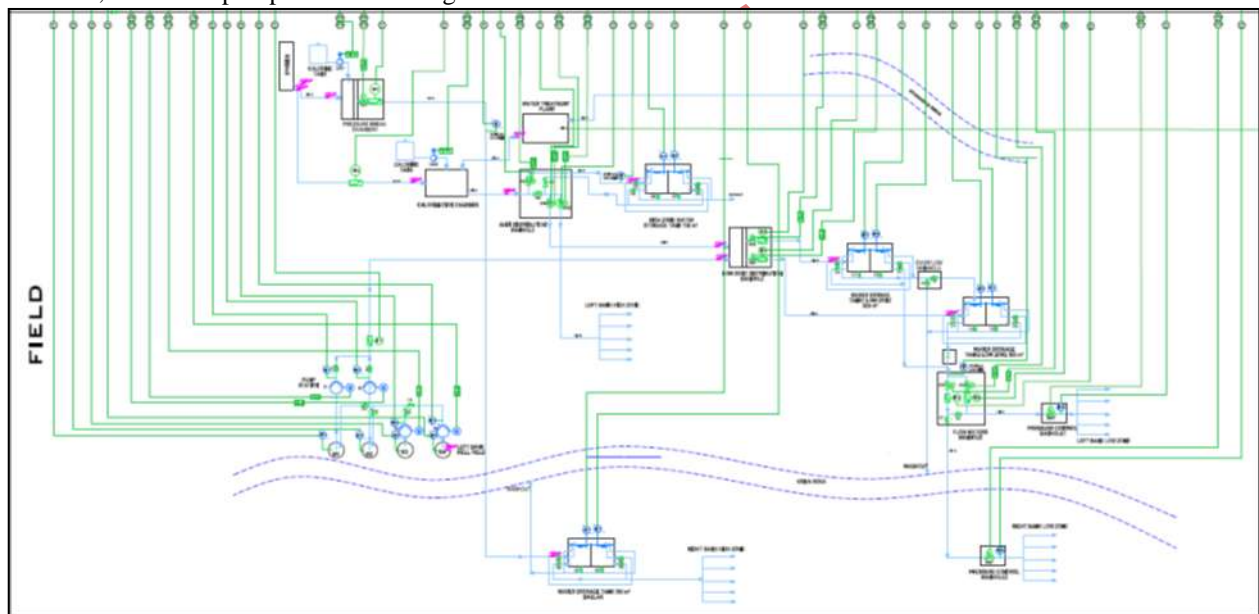

Fig 2: First layer of a SCADA system with field instruments, remote terminal units and field control devices

The system has to provide efficient and safe operation of the process plant by detecting alarm and error conditions, visually and audibly alerting the operator, monitoring all important system parameters and has to provide advising strategy for system optimization. The system allows operators, technicians and engineers to issue commands to change system parameters, start and stop equipment, provide configuration tools and operate diagnostic facilities.

The new project for WSS in the analyzed city intakes the water from Kalin Kamen through F219 steel pipes to the location Crvena Niva.

Another separation pipe F150 is set to the connector and chlorinating station through which the water is distributed to the tank. The tank is placed on the right bank of Kriva Reka for high zone Baglak 3 and is composed of two independent chambers. The plug at Crvena Niva has a pressure break tank 1 to reduce the hydrostatic pressure in

the inlet pipeline. The break pressure tank obtains wet and dry chamber. In the break pressure tank are placed the valves, with which the flow of the water is regulated manually in the tank, for the high zone

Baglak 3. In the same break pressure tank the chlorination is done with electromagnetic dosing pump.

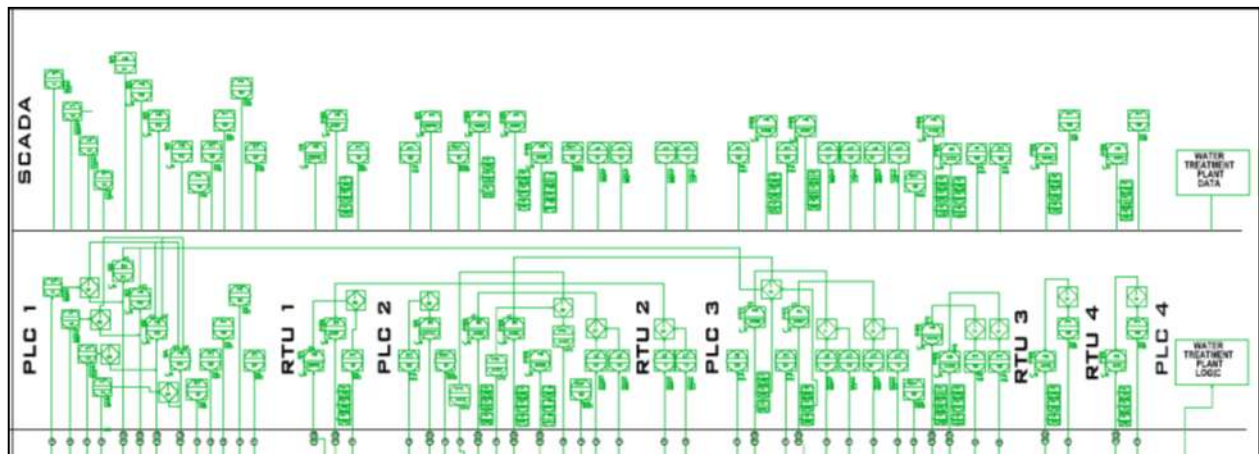

Fig 3: Second and third level of a SCADA system with PLC units and computers

In the new project for automation the system will be provided an automation of the existing valve with installation of an electric actuator for valve AV01. In the tank in the zone Baglak 3, two ultrasonic level transmitters LIT11 and LIT12 will be incorporate, one for each chamber. This system will achieve automatic regulation of the level of the water in the tank in zone Baglak 3 and will avoid unnecessary overflow, i.e. loss of water.

In case, when the water in the tank will come at a high or low level the transmitters LIT11 and LIT12 will give an alarm signal to the operators, and in case when the water level in the tank is high-high (before overflow) the transmitters LIT11 and LIT12 will give control signal to the automatic valve AV01 in the break pressure tank 1 to close the water supply.

In case of reduced water levels in the tank at a minimum depth (low – low level) the transmitters LIT11 and LIT12 will give a command to the automatic valve AV01 to open. In the same shaft will be installed an electromagnetic flowmeter FIT01. The flowmeter FIT01 will control the dosing of chlorine in the water supply system for the zone Baglak 3.

The flowmeter FIT01 will give a control signal to the dosing pump for chlorine CDP01, which according to the flow will be dosing the required amount of chlorine. Residual chlorine will be monitored by installing a residual chlorine transmitter RCIT01 after the break

pressure tank 1 in the pipeline with F150 for high zone Baglak 3 near the Filter station.

The F219 pipeline continues to the main distribution shaft, located to the filter station at elevation 780 meters above sea level. Before the main distribution shaft, the pipeline enters first in the prechamber for chlorination, in which the water comes from the Stanechka river and previously passes through the filter station. It is a surface water from the river that must be filtered and also chlorinated in the filter station. So the chlorination in the prechamber for chlorination is necessary only for the water that comes from the springs of Kalin Kamen.

For proper chlorination it is necessary to install a flowmeter FIT02, before the prechamber chlorination. The flowmeter FIT02 will provide a control signal to the dosing pump for chlorine CDP02, which depending on the flow will be dosing the required amount of chlorine. The residual chlorine will be monitored by installing a residual chlorine transmitter RCIT01, after the break pressure tank 1 of the pipeline with F150 for high zone Baglak 3 near the filter Station.

The residual chlorine will be monitored by installing the two residual chlorine transmitters RCIT02, located before the the tank, for the left coast of the high zone and residual chlorine transmitter RCIT03, located in the measuring shaft after the tanks, for low zone, left and right coast. An additional manual fine-tuning of the dosage of chlorine will be provide based on these measurements.

From the prechamber for chlorination, with a pipe F300, the water is transferred to the main distribution shaft located in front of the water tank. From this shaft with the help of 4 manual valves the water is transferred to the tank of 150 m³ for the left coast in the high zone, or directly into the distribution network for the left coast in the high zone and to the two tanks of 500 m³ for the left and right coast for the low zones.

For automatic control of the distribution of water in the areas on the left and the right coast, must be upgraded 3 electric actuators in the same shaft, for 3 manual valves (valves AV02, AV04 and AV05). The automatic valve AV02 shall control the water level into the tank of 150 m³ for the high left zone, using the control signal from the level transmitters LIT05 and LIT06, which will be installed in both chambers of the tank itself.

The automatic valve AV04 will control the distribution of the water into the tank of 500 m³ for left coast in the low zone, which will be explained below. The automatic valve AV05 will control the distribution of the water directly into the distribution network, for left coast in the high zone. All three automatic valves AV02, AV04 and AV05 will have direct interaction, to balance the supply and drainage of water in the main distribution shaft.

The third electric valve AV05 will close and open, inversely proportional from the first two valves AV02, AV04 (when the first two valves close the third opens). The interaction of the valves will be done through analog positioners to each of these valves VPIC02, VPIC04 and VPIC05.

The water from the main distribution shaft is distributed through the automatic valve AV04 in the distribution shaft for the left and right coast in the low zone, which is located at elevation 730 m asl. The water from the wells of Kriva Reka, which are located at elevation 640 m asl, is supplied in this shaft. Because of the height difference of the water, the water from the wells must be pumped with high pressure pumps, to the distribution shaft for low zone.

The shaft itself includes dry and wet chamber. In the dry chamber, there are two manual valves, which regulate the distribution of the water in the tanks 1 and 2 for the left and right coast in the low zone. Two electrical-valve actuators, AV06 and AV07 and two flow transmitters FIT03 and FIT04, should be built in this shaft. In the tanks 1 and 2 (for the low zone), which have two independent chambers, should be installed level transmitters. LIT07 and LIT08 for the tank 1 of elevation 721 m asl and LIT09 and LIT10 for the tank 2 at elevation

708 m asl (total number is 4 - one in each chamber).

Level transmitters, LIT07 and LIT08, will provide a control signal to the automatic valve AV06 to control the water level in the tank 1. Level transmitters, LIT09 and LIT10, will provide a control signal to the automatic valve AV07 to control the water level in the tank 2.

In case, when the water in the tanks will come at a high or low level, the level transmitters will give an alarm signal to the operators, and in case when the water level in the tanks will come at a high-high (before overflow) level, the level transmitters, will provide a control signal, to the inlet, automatic valve to close the water supply. In case of reduced water level into the tank at a minimum depth (low- low level) the level transmitters will give a command to the automatic valves to open.

When both of the valves AV06 and AV07 are fully closed and their end switches for closed position, ZSC06 and ZSC07 are closed, then they will provide a control signal to the valve AV04, located in the main distributive shaft to shut the water supply from the springs of Kalin Kamen and also, to the pumps for the wells, to stop pumping the water.

The water from the tanks, for the low areas, is distributed through the distribution shaft for measuring the flows. In the distribution shaft there are two manual valves AV08 and AV09. One is to control the distribution of the water in the left coast of the low zone, and the other to control the distribution of the water in the right coast of the low zone. These valves should be automated with adding electric actuators.

After the valves, two flow transmitters, FIT05 and FIT06, should be integrated. With the flow transmitter FIT05, the amount of water distributed on the right coast in the low zone, will be measured. A flow transmitter FIT06 will measure the amount of water distributed on the left coast in the low zone.

Before the distribution network for the left coast in the low zone, a shaft is located to control the pressure. The automatic valve AV10 and the pressure transmitter PIT05 will be installed into it. The control signal of the pressure transmitter PIT05, will control the pressure in the distribution network of the low zone, to be at a constant level, from 4 to 5 bar, by opening and closing the valve AV10.

Before the distribution network for the right coast in the low zone, a shaft is located to control the pressure. The automatic valve AV11 and the pressure transmitter PIT06 will be installed into it. The control signal of the pressure transmitter PIT06, will control the pressure in the

distribution network of the low zone, to be at a constant level, from 4 to 5 bar, by opening and closing the valve AV11.

The field of the wells of Kriva Reka, has 4 wells W1, W2, W3 and W4. Two of these wells W1 and W2, work as wells, and also as collection tanks in which, the water from the other two wells W3 and W4 is pumped using small pumps from 5KW. The water from the main wells W1 and W2 is pumped in the distribution shaft for low zone, with larger, high pressure pumps, from 17.5 KW.

All wells are equipped with the level transmitters LIT01, LIT02, LIT03 and LIT04.

Level transmitters LIT01, LIT02, LIT03 and LIT04, will provide a control signal to the corresponding pumps P1, P2, P3 and P4. In case when the water in the wells comes at a high or low level, the level transmitters will give an alarm signal to the operators. In case when the water level in the wells W1 and W2 comes to high-high (before overflow level) the level transmitters will give a control signal to the pumps P3 and P4, to stop the pumping in the tanks W3 and W4.

In case of reduced water level in the wells, to a minimum depth (low level), the level transmitters will give a command to the appropriate pumps to stop the pumping in order to protect them from damages, which are happening when the pump is working and there is no water. Level transmitters LIT01, LIT02, LIT03 and LIT04 will give signal to the PLC panel for the pump station, or will give a signal to the SCADA center. With this signal the water level in the wells, will be shown on the mimic display.

To each pump, local control panels are installed, with start /stop buttons, and selector switches for the local / remote work. In case the operator selects the local mode then he would be able to operate the pumps with the local panels with start /stop buttons. In case the operator selects remote mode then he would be able to operate the pumps from the engine control panels, located in the engine room of the pump station.

The filter station for the Suva Reka water treatment is in its final phase of construction. In this station a local PLC panel will be built and it will monitor the work of the filter station itself. After completing the construction and putting it into operation, a PLC panel will be connected via GPRS / GSM modem with the SCADA center. In addition, only monitoring of the work of the filter station will be performed. The operating will be possible only locally, through the local PLC panel.

4. FURTHER DEVELOPMENT

SCADA system is well known and implemented in the industry. SCADA applications via PLCs are designated to operate on certain, predefined scenarios, in which the limiting/ triggering parameters for particular actions are known in advance, just as the action schemes to be undertaken should a trigger occurs.

Initial triggering parameters for the PLCs to take action are based on knowledge and experience of the operating personnel. Meanwhile, a database is picking up the parameters from the PLCs and RTUs and creates a time-based history of the values. The results collected are analyzed through adequate algorithms using data mining techniques to create timed envelope values that are returned to the PLCs. Should an excess situation occurs, such as less water in the sources, defects within the network etc., an algorithm is activated to reconfigure the WSS network (PLCs parameters for the actuators, electric valves, shutters etc.). Once the situation is resolved/ stabilized (monitored by the sensors/ RTUs), the software returns the regular control to the automatics.

The system also controls the manual override on the proactive units, so no unauthorized intrusions are allowed, unless approved by the operator (for technical maintenance, defects or such) which significantly increases the safety of the WSS against voluntary or hostile actions.

SCADA system also controls the quantity of the water supply, hence enabling the WSS companies to obtain adequate billing for the services rendered. This very point also allows the SCADA to locate defects within the network (loss of water, pressure) indicate and undertake adequate actions for the resolution of the problem.

5. CONCLUSION

The implementation of this project will significantly contribute to improving the standard of living of the local population, regular and continuous supply of quality drinking water and maintenance of the cleanliness and the hygiene to a higher level. The project will enable the further development of those parts of the city with intensive construction.

SCADA systems generally have a huge role and application in today's technology and they are making the process of control and automation of the systems significantly easier and more reliable.

6. REFERENCES

- [1]. K. Stouffer, J. Falco and K. Kent, "Guide to Supervisory Control and Data Acquisition (SCADA) and Industrial Control Systems Security", National

- Institute of Standards and Technology Special Publication 800-82, 2006.
- [2]. D. Bailey, and E. Wright, Practical SCADA for Industry, IDC Technologies, 2003.
- [3]. S. Boyer, SCADA Supervisory Control and Data Acquisition, 2nd edition, ISA, 1999.
- [4]. J. Slay and M. Miller, "Lessons Learned from the Maroochy Water Breach", IFIP International Federation for Information Processing, vol. 253, Critical Infrastructure Protection, eds. E. Goetz and S. Sheno (Boston: Springer), pp. 73-82, 2007.
- [5]. M. Dobriceanu, A. Bitoleanu, M. Popescu, S. Enache, E. Subtirelu, "SCADA System for Monitoring Water Supply Networks", WSEAS Transactions on Systems, vol.7 no. 10, pp. 1070-1079, 2008.
- [6]. Technical Report, Water Supply Company, Municipality Kriva Palanka, 2010.

IJournals