

Analysis of Stability Enhancement Using AI Technique on Hybrid Solar-Wind Energy In Power System

Author: Neha Singh¹, Author²: Ritesh Nagar²

Affiliation: Assistant Professor, School of Engineering & Technology, Vikram University Ujjain¹

Affiliation²: Research Schloar²

E-mail: singh.neha659@gmail.com¹; rn4777@gmail.com²

ABSTRACT

In this paper a study of Hybrid system (solar-wind) model is designed in MATLAB/SIMULINK which is connected directly with two alternators in electrical power system. The main aim is analysis the level of a total harmonic distortion (THD) of output voltage. For these different types of controlling techniques has been given for stable power system. Different controlling techniques such as Constant Frequency Control, Constant Tolerance Band Control, Variable Tolerance Band Control, Discontinuous Current Control using with Artificial Intelligence (AI) is implemented for relative analysis. It is seen that the distortion level of waveform (output voltage) is less by using Constant Frequency Control technique in hybrid electrical power system.

Keywords: Hybrid system, Total Harmonic Distortion (THD), Artificial Intelligence (AI), Constant frequency control.

1. INTRODUCTION

The Hybrid wind-solar power system defines the two renewable energy sources. The main elements of these power system includes wind turbine and solar power station, with battery and the power management center that is used maintain the

electrical power generation. This type of arrangement is the type of the micro-grid construction having power generating unit, loads and batteries. Now a day's micro-grid is very popular due to the easy installation and wide advantages over the conventional power generation using with AI technology with trains a system to react and handle the system during uneven condition and to achieve reliability.

An additional ability as well as advantage of micro grids is that during the condition of the faulty situation due to which harmonics, transients, variation infrequency and other disturbing elements produced can be removed from utility grid easily. For the enhancement of power system the output capacity of the system is connected before its integration with the hybrid solar power which is designed with Wind energy on MATLAB/SIMULINK. After designing hybrid system a Universal Bridge of the three leg stabilizer is used as a controller is combined and integrated on MATLAB/SIMULINK the Universal Bridge of the three leg stabilizer provide controlling of output voltage so that the hybrid system will work efficiently. As past we know that the conventional pulse width modulation (PWM) technique is used in bridge to control the output

voltage to enhance the power quality, but it is not sufficient and does not able to correct the power as desired values. By taking it one step forward we uses a Universal Bridge of the three leg stabilizer. This provides a comprehensive optimal sizing, energy management, operating and control strategies and integration of different renewable energy sources to constitute a hybrid system. It also uses the different errors produced in micro grids and with include distributed generation, micro grid value propositions, applications of power electronics, economic issues, micro grid operation and control, micro grid clusters, and protection and communications issues. In today's world the requirement of electrical energy going to shift on the renewable energy due to which there is a fast progression of this energy market, aim of combining different sources of energy sources is that a hybrid renewable energy system (HRES) has more advantage as compared to single unite power generation. The wind and solar integrated hybrid power system applications have remote standalone or dispersed grid-connection and also have a combination of both applications which is connected to the large power generating units.

2. PROBLEMS IN HYBRID SYSTEM

During the operation of wind and solar power as we know that the hybrid system have a several drawbacks, while hybrid systems are intermittent in natures that make unreliable. If we use only wind power to generate electricity which is able to supply high amounts of power, but we also know that its operation is highly uneven because the propellers of the wind mill can rotate due to the flow and availability of wind. And same with the solar power plant as solar energy is present only during day but the amount of solar irradiation levels is changing the intensity of solar irradiation

is effected by uneven cast by clouds, wither conditions etc. But the wind and photovoltaic power have the higher potential to fulfill our energy requirements and can be achieved by using AI technique. AI is a system which learns the from the system itself and commend the controller to react only when the input is given by it. Both Wind and Solar power are then on-conventional sources of energy that helps to lower down the issue of the global warming and lower down the use of fossil fuel reserves, which helps to make our environment healthy.

3. MODELING COMPONENTS

While the condition of if the source uneven due to that is not able to generate electricity or unavailable, the other energy source use to compensate the difference. Several hybrid wind and solar hybrid system uses the tracking maximum power point tracking mechanism (MPPT) to control the output power. The MPPT technique is used in our system to enhance the performance. In many systems literatures they use separate DC/DC boost converter connected in parallel in the rectifier stage as shown in Figure 1 works as MPPT control for wind and solar hybrid system uses the tracking maximum power point. A normal multi-input connection is also used to connect the wind and solar hybrid from the DC-end for MPPT. The connections which are made is combination of buck and buck-boost converter. Therefore, by connecting two intermittent renewable sources with MPPT. The MPPT algorithms enhances the power transmission, efficiency and reliability of the system.

This system can perform on both Individual and simultaneous operation of wind and solar generating plant over wide range and can support

step up/down operations for each renewable source. MPPT is used for the each source features of the proposed mechanism is that it is basic need two system remove the requirement of separate input filters to correct the power factor. AI is integrated with the MPPT, Cuk and SEPIC converters. The give method is a combination fusion of Cuk and SEPIC converters connect with the AI. During operation harmonic are also produced due to which lower the value of current lifespan and rise in power loss due to heating. For these filters are used to remove the high frequency current harmonics injected into wind turbine generators.

The system has the front-end rectifier stage in a hybrid energy system. This type of connection provides the freedom for both the energy sources to supply the load separately or simultaneously depending on the availability of the energy sources. While the operation and control of power system the main aim to provide quality power to utility and also economical for the users. The demand of the electricity is increasing day by day So to fulfill the

demand a AI technology has to be used and integrated with hybrid solar and wind power system. Artificial intelligence (AI) is a tool, which are fast, robust and adaptive and can overcome the drawbacks of conventional methods for different power systems problems. In this work, applications of AI techniques have been studied for solving losses in hybrid power system.

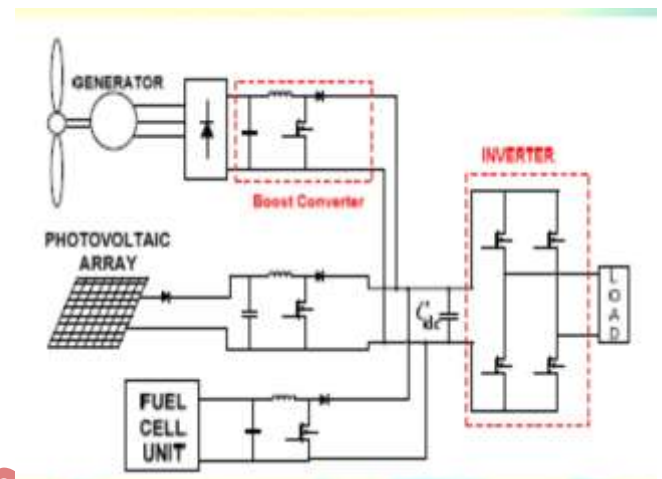

Figure No 1

4. POWER SYSTEM MODELLING

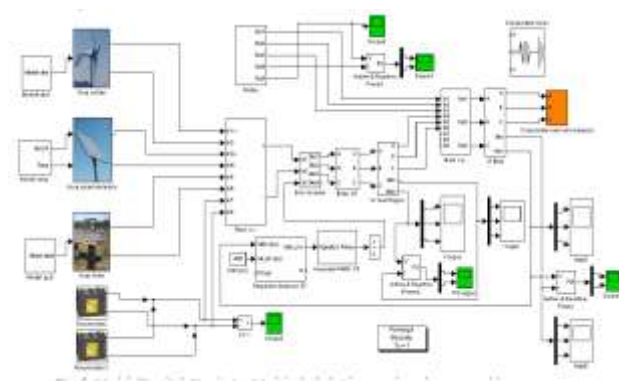

Figure No. 2

The computer software of the given system is mainly done the numerical analysis. So it is typical to perform the selective processing during operation of the hybrid system, mainly in faulty conditions. By artificial intelligence techniques to to perform the selective processing during operation because operational personnel to check and judge greatly reduces the workload of operational staff also improves the efficiency of dealing with incidents. This is one of the main causes in recent years that researches on application of electric power stream with artificial intelligence (AI).

Harmonic produced due to which it lower down the value of current lifespan and rise in power loss due to heating a. The fused multi input rectifier stage

provides MPPT to be used to reach and produce maximum power by both wind and sun during their availability. MPPT algorithm is used only in wind power with standard perturb and observe method is used for the solar. Now, Ćuk converter that is DC-DC converter which have the output voltage even greater than or less than the input voltage. MPPT is a high efficiency DC to DC converter use as electrical load to a solar panel or array and generate suitable voltage for the load.

5. AI INTEGRATION

The Artificial intelligence (AI) is one of the best technologies, which is integrated with Maximum Power Point (MPPT). MPPT is used to correct the output voltage from the hybrid grid which is compact with AI and AI is a technology which learns from the system data itself, this data is analyzed and gives a prediction to the system to correct the power. This predicted data is then given into the MPPT and DC-DC converter which maintain the value of output voltage of power at suitable consideration, so that the hybrid system can produced maximum output voltage.

6. CONCLUSION

The Hybrid solar-wind power system is the need to fulfill the today's energy requirement. This system can be modified and use the AI technology in MPPT which enhance the overall performance of the hybrid system, so the system become more reliable, efficient, compress energy losses, enhance stability and helps in generating output voltage which is more cost effective with this technology.

7. REFERENCES

[1] K. Shivarama Krishna, Sathish Kumar K. A review on hybrid renewable energy systems. *Renewable and Sustainable Energy Reviews* 2015; 52: 907–916.

[2] Parhizi S., Lotfi H., Khodaei A., Bahramirad S. State of the art in research on microgrids: a review. *IEEE Access* 2019; 3: 890–925.

[3] Mahmoud Ghofrani and Negar Nirom and Hosseini Optimizing Hybrid Renewable Energy Systems: A Review, 2016 intechopen science

[4] Post HN, Thomas MG. Photovoltaic systems for current and future applications. *Sol Energy* 1988;41(5):465–73.

[5] Shaahid SM, Elhadidy MA. Opportunities for utilization of stand-alone hybrid (photovoltaic – diesel- battery) power systems in hot climates. *Renew Energy* 2003;28(11):1741–53.

[6] Mathew S, Pandey KP, Anil Kumar V. Analysis of wind regimes for energy estimation. *Renew Energy* 2002;25(3):381–99

[7] M. A. Abido, and Y. L. Abdel-Magid, "Optimal design of power system stabilizers using evolutionary programming," *IEEE Trans. Energy Con.*, vol. 17, no. 4, pp. 429-436, December 2012.

[8] K. E. Bollinger, and S. Z. Ao, "PSS performance as affected by its output limiter," *IEEE Trans. Energy Con.*, vol. 11, no. 1, pp.

[9] K. C. Lee, "Analysis of power system stabilizers application for controlling poorly damped oscillations in the ALCAN/B.C. Hydro power systems," *IEEE Trans. Power Sys.*, vol. 8, no. 1, pp. 255-263, February 1993.

[10] N.G. Hingorani (2019). "Understanding of FACT concept technology of flexible ac transmission system", IEEE Power Engineering IEEE press, Wiley India.

[11]. L. Gyugyi. (1988). "Power Electronics in electric utilities: Static VAR Compensator", *Processing of IEEE*, Vol.7, No.4, pp.483-494.

[12] N. Hingorani, L. Gyugyi, (2010). "Understanding FACT concept technology of flexible AC transmission system", IEEE Press, Newyork.

[13] NagarjunDonipalaet. al. (2014). "An Adaptive Power System Stability Enhancement using Static

Synchronous Series Compensator (SSSC)", *Int. Journal of Engineering Research and Applications*, ISSN:2248-9622, Vol.4, No.1, pp.261-265.

[14] B.M. Naveen Kumar Reddy, Himani Goyal. (2013). "Power System Stability Enhancement using Static Synchronous Series Compensator (SSSC)", *International Journal of Modern Engineering Research (IJMER)*, Vol.3, Issue.4, pp.2530-2536.

[15] H. Taheri, S. Shahabi, Sh. Taheri and A. Gholami (2009). "Application of Synchronous Static Series Compensator (SSSC) on Enhancement of Voltage Stability and Power Oscillation Damping", *IEEE Transactions on Power System*, pp.533-539.

[16] Abido M. A. (2009). "Power System Stability Enhancement Using Facts Controllers: A Review", *The Arabian Journal for Science and Engineering*, Vol.34, pp.153-172.

[17] B.N. Singh, A. Chandra, K.AI-Haddad and B. Singh (1999). "Performance of sliding- mode and fuzzy controllers for a static synchronous series compensator", *IEEE proceedings*, Vol.146, No.2, pp.200-206.

[18] G. N. Pillai, A. Ghosh, A. Joshi, (2000). "Torsional interaction studies on a series compensator based on solid-state synchronous voltage source", *Industrial Technology 2000, Proceedings of IEEE International Conference on*, Vol.2, pp.179-184, 19-22.

[19] Sen K.K, (1998). "SSSC-Static Synchronous Series Compensator: Theory, Modeling and Publications", *IEEE Trans. Power Delivery*, Vol.13, No.1, pp.241-246.

[20] A. H. Norouzi, A. M. Sharaf, (2005). "Two control schemes to enhance the dynamic performance of the STATCOM and SSSC", *IEEE Trans. Power Delivery*, Vol.20, No.1.

[21] Ritesh Nagar, S. K. Bhatt, "A Comparative analysis of a Conventional and cross phase UPQC for enhancing the Power Quality," vol. 7, no. 7. *IJSHRE*, 2018.

[22] Amit Marmat and Ritesh Nagar, "Appropriateness of Parametric Bootstrap System for Appraise Mean Time to Failure of a Problematical System", *International Journal of Research in Engineering, Science and Management*, vol. 3, no. 12, pp. 161-163, Dec. 2020, [doi: 10.47607/ijresm.2020.428](https://doi.org/10.47607/ijresm.2020.428)

[22] Amit Marmat and Ritesh Nagar, Analysis of Non-Parametric Bootstrap & Monte Carlo simulation Methods to evaluate MTBF during Faulty Conditions", *International Journal of Emerging Technologies and Innovative Research (www.jetir.org)*, ISSN:2349-5162, Vol.8, Issue 1, page no.69-74, January-2021, <http://www.jetir.org/papers/JETIR2101011.pdf>