

Speed Control of PMSM based on Particle swarm optimization Method to tune PI parameters

Ms. Aastha Singh Chandel¹, Mr. Pawan Pandey²

¹ M. Tech Scholar in Power Electronics, MIT, Indore (M.P). E-mail: (aastha190391@gmail.com)

² Assistant Professor & head in Electrical & Electronics Dept. MIT, Indore (M.P). E-mail: (pawanpandey@mitindore.co.in)

DOI: 10.26821/IJSHRE.9.1.2021.9135

Abstract:

PMSM normally used when there is high demand for its characteristic of speed stability and synchronous operation. Nowadays, due to advanced system, PMSM receives an attention and widely use due to its advantageous features such as high efficiency, low noise as well as high power density. This thesis proposes the optimization of the PI gain used in the speed control of permanent magnet synchronous motor (PMSM). The optimization technique used in this project is Particle Swarm Optimization. PMSM can be built in different structures which may have been constructed from two to fifty or more magnet poles. In this project, field-oriented control is used to control the speed of the PMSM.

The PSO is used to find the finest gain of the speed- PI so that the speed error will be minimized and it is designed to achieve the specific objective function. In this paper, the objective is to reduce the steady state error of the system drive. By randomly initialize, these particles fly through the search space dimension to evaluate and updating their positions and velocity. As updating the

position and velocity, the personal and global best value also keeps updating until it finds better fitness and achieve the optimal value. The simulation results proved that the proposed technique can reduce the speed error close to zero and get the better result compared to the heuristic method. This research work presents a novel design of speed control for a permanent magnet synchronous motor using evolutionary techniques called Particle swarm optimization method.

1. Introduction

The speed control of the PMSM has been an important subject recently. Today, numerous modern industries are controlled utilizing proportional plus integral (PI) controllers. The notoriety of the PI controllers can be ascribed to their great execution in an extensive variety of working conditions, useful straightforwardness, which enables Engineers to work them in a basic, clear way and recognition, with which it is seen among analysts and experts inside the procedure control enterprises. Regardless of its, the board utilizes, one of its fundamental deficiencies is that there is no effective tuning technique for this sort of controller.

A few strategies have been proposed for the tuning of PID controllers. Among the customary PI tuning strategies, the Ziegler–Nichols strategy might be the most surely understood. For an extensive variety of useful procedures, this tuning approach works great. Be that as it may, now and then it doesn't give great tuning and tends to create a major overshoot. Consequently, this strategy typically needs retuning before connected to control mechanical procedures. To upgrade the capacities of conventional PI parameter tuning systems, a few insightful approaches have been proposed to enhance the PI tuning, for example, genetic algorithm and particle swarm optimization, etc.

It has been affirmed that the greater part of the modern controllers being used today use PI or modified PI control plans. This across-the-board acknowledgment of the PI controllers is generally ascribed to their effortlessness and powerful execution in an extensive variety of working conditions. One noteworthy issue looked at in the organization of PI controllers is the best possible tuning of pick-up values. Throughout the years, different heuristic procedures were proposed for tuning the PI controller. Among the soonest techniques is the established Ziegler-Nichols tuning system, in any case, it is hard to decide ideal or close ideal parameters with this because most mechanical plants are regularly exceptionally complex having high order, time delay, and nonlinearities.

2. Literature review

Impressive work has been done in the past on the design of PMSMs with various rotor designs. For exterior PMSMs, some essential plan models for torque ability, loss estimation, thermal properties, and magnet insurance have been set up by Slemon [19, 20]. A detailed plan case of surface mounted

PMSM is given by Panigrahi [21]. The planning strategy proposed in these papers created inexact relations for deciding the real engine measurements to meet a plan detail. These relations are valuable in getting an estimation of what can be accomplished before a definite engine configuration is done. Be that as it may, a large portion of the plan relations is communicated in the shape which is autonomous of the attributes of the inverter supply to the engine. These PM engines are prepared to do high torque, furthermore, increasing speed, especially in the typical speed extend, yet they are not appropriate for rapid activity because of poor magnet insurance and motion debilitating ability.

For the ordinary plan of inside PMSMs, the proportion of rotor saliency is as high as 2 to 3 [11]. The required engine parameters can be accomplished through various offbeat rotor arrangements [16, 17, 18, 25]. It is demonstrated that a high saliency proportion and a low PM excitation motion can be accomplished by sandwiching adaptable sheets of magnets between hub covers as appeared in [16]. The favorable position of this development lives in its low PM motion and extensive steady power speed run.

Past outline contemplates having considered just saliency proportions more prominent than solidarity. By the by, developments with $L_q/L_d < 1$ are conceivable either by utilizing single or different q-axis transition hindrances [17] or by utilizing a rotor with two pivotal parts: one non-notable (outside PMSM) and the other of the synchronous hesitance compose [18]. It is demonstrated that this sort of engine permits a lower estimation of evaluated current and shows a bigger speed run for transition debilitating tasks. In any case, both the rotors with low and high saliency proportions have the particular burdens that the

mechanical structure restrains the most extreme speed, what's more, requires offbeat assembling innovation.

The issue of transition debilitating utilizing current control was first featured by Jahns. He proposed a restorative technique for control of the standard vector control design [13]. An input of current controller mistake in the synchronous organizes was managed to zero through a PI-controller by lessening the d-pivot current I_d and in this manner getting the q-pivot current I_q . Another technique introduced by Sul utilizing a PI control of the voltage blunder between the immersed voltage and the yield voltage order of the PI current controller to change the d-axis current order [52]. Then again, the plan introduced by Morimoto takes a gander at voltage reference to decide the control modes between consistent torque also, transition debilitating [51].

3. Modelling of PMSM

The ordinary plan technique for PM machines depends on the planner's involvement. To outline a synchronous engine with astounding execution and monetary cost, it is important to do an ideal plan of the structures of the PMs in the engine. Rising out of the advancement up until this point, the PMSM has a wide range of sorts of rotor PM structures. By and large, the essential three conspicuous PM game plans of rotor structures are surface mounted magnets, radially polarized magnets (inserted type), what's more, circumferentially charged magnets (talked type) [8– 11].

The d-and q-organize based proportionate circuit demonstrate is utilized for the displaying of PMSMs. Fig. 3.2 delineates a calculated cross-sectional perspective of a 3-stage, 2-shaft inside PMSM alongside two reference outlines. To demonstrate the inductance contrast ($L_q > L_d$), the

rotor is drawn with saliency. The electrical unique condition regarding phase factors can be composed as:

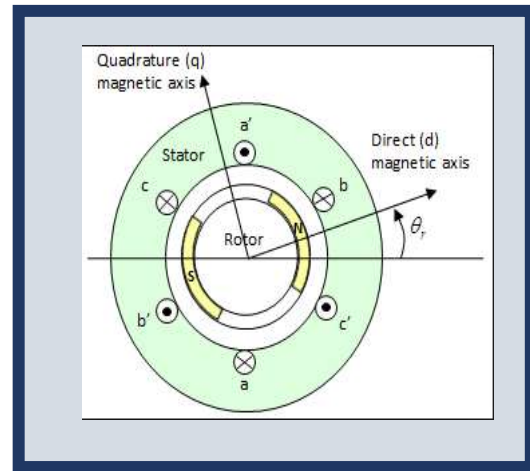

Fig. 1 Cross-sectional view of the motor

$$V_a = RI_a + \frac{\partial \varphi_a}{\partial t} \quad (3.1)$$

$$V_b = RI_b + \frac{\partial \varphi_b}{\partial t} \quad (3.2)$$

$$V_c = RI_c + \frac{\partial \varphi_c}{\partial t} \quad (3.3)$$

Where, V_a, V_b, V_c are phase voltages, I_a, I_b, I_c are phase currents and R is resistance. The flux linkages ($\varphi_a, \varphi_b, \varphi_c$) are as:

$$\varphi_a = L_{11}I_a + L_{12}I_b + L_{13}I_c + \varphi_{ma} \quad (3.4)$$

$$\varphi_b = L_{21}I_a + L_{22}I_b + L_{23}I_c + \varphi_{mb} \quad (3.5)$$

$$\varphi_c = L_{31}I_a + L_{32}I_b + L_{33}I_c + \varphi_{mc} \quad (3.6)$$

Where, ($\varphi_{ma}, \varphi_{mb}, \varphi_{mc}$ are a component of phase flux linkages given by permanent magnets. In the above equations, inductances are functions of the angle θ . When the rotor q-axis is line up with the phase axis, then stator self-inductance is reached its maximum. On the other hand, mutual inductances reach their maximum value when the rotor q-axis is in the middle between the two phases. The

consequence of saliency comes into view in the stator self and mutual inductances which are indicated by the expression 2θ . In the interim, the flux linkage at the stator windings owing to the permanent magnets is:

$$\varphi_{ma} = \varphi_m \cos\theta \quad (3.7)$$

$$\varphi_{mb} = \varphi_m \cos\left(\theta - \frac{2\pi}{3}\right) \quad (3.8)$$

$$\varphi_{mc} = \varphi_m \cos\left(\theta + \frac{2\pi}{3}\right) \quad (3.9)$$

For this system the input power can be represented as:

$$P_{input} = V_a I_a + V_b I_b + V_c I_c \quad (3.10)$$

To find the phase currents from the flux linkages, the inverse of the time-varying inductance matrix will have to be computed at each time step [4]. The calculation of the inverse at each time step is prolonged and could create problems of numerical stability. To overcome such quantities in voltages, currents, flux linkages, and phase inductances, stator quantities are changed to a d-q rotating reference frame using Park's transformation. Such consequences in the equations having time-invariant coefficients.

4. Introduction to PSO

PSO calculation depends on swarm intelligence(SI). The strategy got inspiration by noticing the social collaboration, practices of creatures seen among birds, fishes and so on. PSO follows the technique that is found in fishes, where they discover food by contending and the coordinating among themselves. The multitude has people which are considered particles in which every molecule addresses different conceivable arrangement of the boundaries that are obscure which ought to get improved. A 'swarm' is normally instated by a populace of arbitrary

arrangements. In this framework, particles fly's around in a multi-dimensional hunt space. It continues changing its situation as for its own insight and furthermore by thinking about the experience of its adjoining molecule.

The objective of every molecule is to look through an answer effectively to accomplish this. The particles swarm among themselves and moves to the best capacity which is called fitting capacity. At that point it unites to a solitary min or max arrangement. A capacity is now characterized and that capacity is utilized to examine the presentation of that molecule. The precision of the regulator that is tuned relies upon model's exactness. So, the framework model is significant. The lone target of this work is to utilize the proposed PSO to accomplish the ideal boundary estimations of a PID regulator that is utilized in a two-tank process. Here we instate a framework with a populace that has arbitrary arrangements. They are called particles. Furthermore, an arbitrary speed is allocated to every one of them. PSO relies upon the data that get traded between swarms (particles). Each multitude adjusts its way to its best wellness work that has been accomplished till that second. This worth is alluded as pbest. In addition, swarms change its way likewise by considering the best past position that was accomplished by its adjoining part. It is alluded as gbest. In the inquiry space the particles move with a speed which is versatile in nature.

A capacity is utilized to break down the presentation of multitude; with the goal that we can discover whether it has achieved the best arrangement. This capacity is called wellness work. As the amassing happens, every molecule attempts to accomplish its best capacity and by the end, particles show a deteriorating pattern. Through this

cycle every molecule gets upgraded. Think about D as the component of search space.

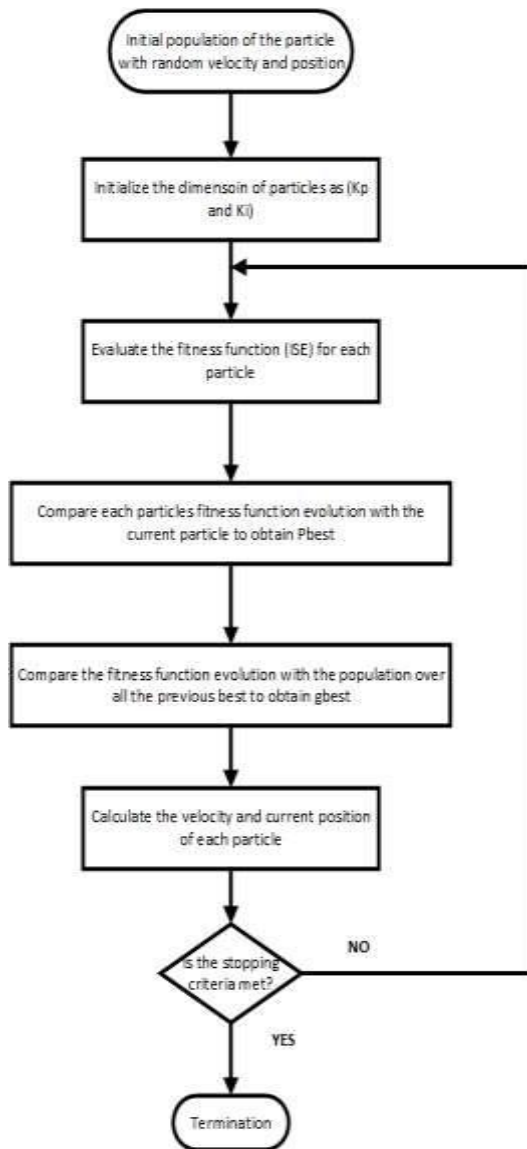

Fig. 2 PSO flow chart

A basic PSO has two phases, exploration and exploitation. In the exploration phase, particles search the most promising regions and in the exploitation phase particle moves towards the best position. PSO finds the global best (gbest) value of particles by changing their position with respect to best position of particles. Local best value (pbest) of each particle communicates their information to the rest of the particles through their neighbors. Therefore, the overall best position of particles attracts the other particles gradually according to the updated velocity of each particle which is

depending on gbest and pbest values. The efficiency of the algorithm depends on the strategy used to select parameters for the next iteration. The basic PSO algorithm requires three steps, namely, generation of particles, positions and velocities, second, update velocity and third, position update. PSO is initialized with the group of random particle positions (x_i^k) and velocities (v_i^k) between upper and lower bound of design variable values as expressed in following equations

$$x_i^k = x_{min} + rand(N, d) * (x_{max} - x_{min}) \quad (3.1)$$

And

$$v_i^k = v_{min} + rand(N, d) * (v_{max} - v_{min}) \quad (3.2)$$

Where, N : number of population.

d : number of parameters to optimize.

k : current iteration count.

x_{min} and x_{max} : minimum and maximum value of particles in search space.

v_{min} and v_{max} : minimum and maximum value of the position of particles to move in search space.

The second step is to update velocities of all particle positions for next ($k+1$) iteration using the particles fitness values which is function of particle positions. These fitness function value determines which particle has a global best (gbest_k) value in the current swarm (iteration) and also determine the best position (pbestⁱ) of each particle.

After finding the two best values, the particles update its velocity and positions of each (i^{th}) particle using following equation:

$$v_i^{k+1} = wv_i^k + c_1r_1(pbest_i^k - x_i^k) + c_2r_2(gbest^k - x_i^k) \quad (3)$$

Where, r_1 and r_2 are the two distinct random values between 0 and 1. c_1 and c_2 are acceleration constant

which are set at 2. These constants help to move particles towards the best possible value ($gbest^k$) and 'w' is the inertia weight used to balance between previous and current best value. Inertia weight change in succeeding iteration as :

$$w = w_{max} - \frac{(w_{max} - w_{min})}{itermax} * iter \quad (4)$$

Where, itermax is the maximum number of iterations. w_{max} and w_{min} , the upper and lower limit of inertia weights which are 0.9 and 0.4 respectively. Now positions of particles are updated using following equation:

$$x_i^{k+1} = x_i^k + v_i^{k+1} \quad (5)$$

5.RESULT AND DISCUSSION

In this section performance of the PSO method for optimization of PI controller for speed control of PMSM motor is analysed and compares its result with Z-N method. A complete comparative simulation model of the PMSM motor using PSO and the G-N method is shown.

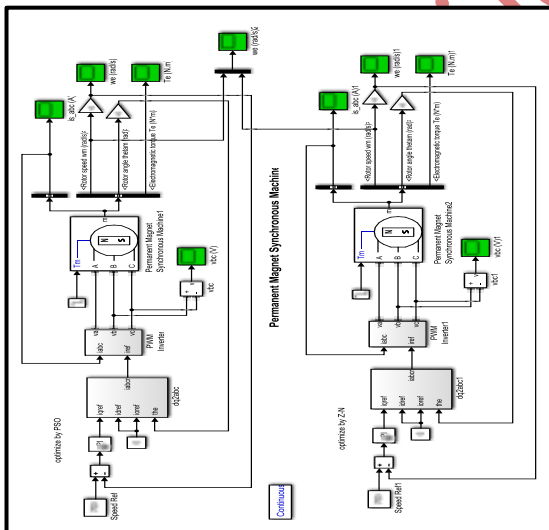

Fig 3 Comparative MATLAB simulation model of PMSM motor

The optimized value of motor is tabulate in table 1

Table 1

Method			Best fitness function	Execution time In sec.
	Kp	Ki		
PSO	1.05	1.727	4.0720333×10^4	85.43486
	7	7	0^4	5
Z-N	50	2.414	4.3935×10^5	105.2567
		7		

(a) Convergence profile: figure 4 and 5 shows the convergence profile of fitness function optimize by PSO method concerning iteration count. This figure clearly illustrates that the value of the global best value of fitness function and mean value of fitness function for the population size of 30 is converged at the best value.

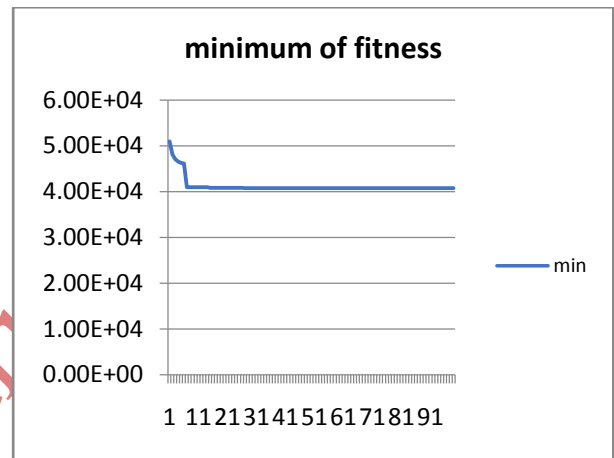

Fig 4: convergence profile of the global best value of fitness function over iteration count

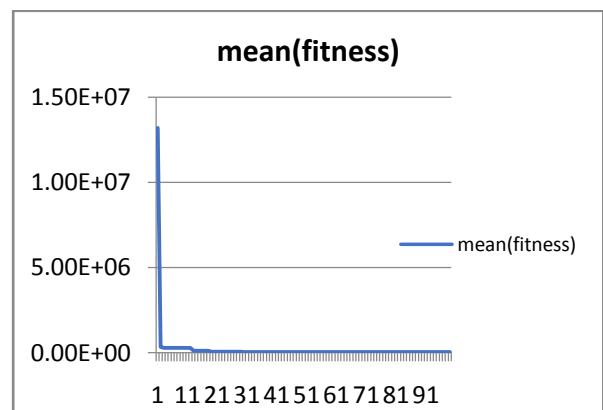

Fig. 5 Convergence of mean value of fitness function over iteration count

Comparison based on statistical evaluation:

Table-2 gives the statistical comparative results for both the method. All stochastic optimization methods start with a randomly generated population and hence to establish their effectiveness, enough runs must be taken. Out of two methods employed for determining the optimal gains of the PI controller, PSO gives the best performance, which is observed from the statistical inference Table-3. It is observed that out of 100 runs best minimum value (4.07203×10^4) is obtained using PSO. Further, the worst maximum (4.07×10^4) is also less than those obtained by Z-N methods. Also, the average value (4.07×10^4) is less than those obtained by other techniques. It is stressed here that the standard deviation (6.70×10^{-11}) is obtained by PSO is significantly less than that obtained by the Z-N method. This shows the robustness of the PSO method over Z-N for the present problem.

Table 2- Statistically comparison of proposed hybrid system

Algorithm	Best value (fbest) in 100 runs	(μ)	median (fbest) in 100 runs	std (fbest) in 100 runs(σ)	runs	runs
PSO	4.07203×10^4	4.07×10^4	4.06×10^4	6.70×10^{-11}	4.07×10^4	80

Z-N	4.3935×10^5	5.935×10^5	4.95×10^5	7.70×10^{-1}	5.35×10^5	5
------------	----------------------	---------------------	--------------------	-----------------------	--------------------	----------

(c) **Time-domain simulation performance:** table 3 shows the comparative analysis of the performance of PSO and Z-N-based optimized PMSM motor in terms of undershooting, overshoot, rise time, settling time, etc.

Table 3: comparative performance evaluation of PMSM motor

Algorithm	Maximum overshoot	Rise time in sec	Settling time in sec	Steady state error	Peak time in sec	Undershoot
PSO	0.956	1.3490	2.4042	0.0004	4.7990	0
Z-N	0.9996	51.3066	91.3512	0.0024	182.5065	0

Fig. 6 shows the comparative step response of speed in rpm of the PMSM motor. This figure clearly illustrates that the performance of PSO optimized controller (shown by the green solid line) have better in terms of overshoot, settling time over Z-N based controller gain.

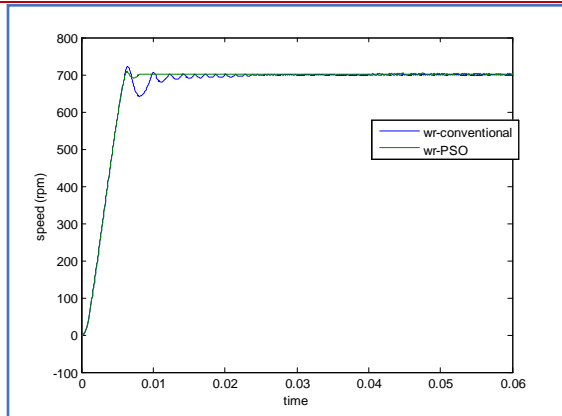

Fig.6 Comparative response of speed of PMSM motor concerning the time

Figure 7 depicts that response of torque concerning time has less oscillation in PSO based optimized PMSM motor compare to the Z-N method. Figure 8 illustrates the three-phase current of PSO optimized PMSM motor which is set at their required value with less oscillation in response.

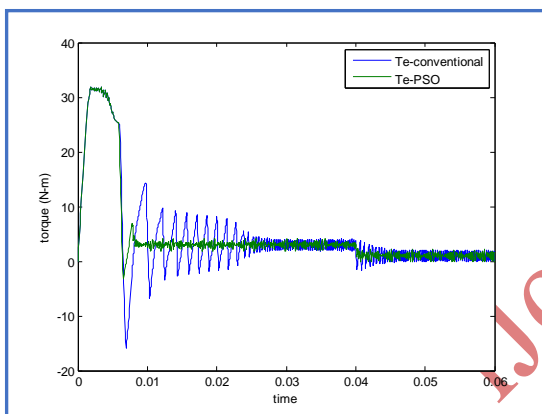

Fig. 7 Response of torque concerning the time

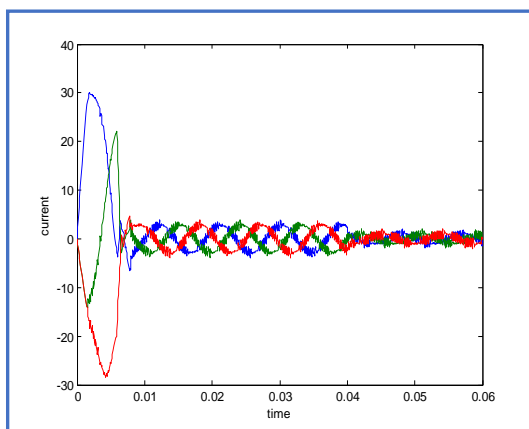

Fig. 8 response of three-phase current of PSO optimize PMSM motor.

6.CONCLUSION

The optimal PI speed controller of a permanent magnet has been designed using the PSO technique to optimize PI parameters instead of using the heuristic technique which is more time-consuming compared to using the PSO technique. The result was based on the case study, which is the condition of reference speed and the electromagnetic torque value. After a few iterations, it clearly showed that the PSO can find the optimal value of the PI parameters and demonstrated a better performance in the steady-state error of the system drive. PMSM falls in the Synchronous Control framework. For the PMSM framework, vector control is picked as a controlling strategy. For this motor drive framework, Control is picked rather than Direct Torque Control (DTC) even though DTC has made incredible progress in controlling AC motor. All stochastic optimization methods start with a randomly generated population and hence to establish their effectiveness, a sufficient number of runs must be taken. Out of two methods employed for determining the optimal gains of the PI controller, PSO gives the best performance, which is observed from the statistical inference. It is observed that out of 100 runs best minimum value (4.07203×10^4) is obtained using PSO. Further, the worst maximum (4.07×10^4) is also less than those obtained by Z-N methods. Also, the average value (4.07×10^4) is less than those obtained by other techniques. It is stressed here that the standard deviation (6.70×10^{-11}) is obtained by PSO is significantly less than that obtained by the Z-N method. This shows the robustness of the PSO method over Z-N for the present problem.

References

- [1] Liu Mingji, Cai Zhongqin, ChengXiming, and Ouyang Minggao, "Adaptive position servo

- control of permanent magnet synchronous motor,” American Control Conference, 2004. Proceedings of the 2004 Volume 1, 30 June-2 July 2004, Page(s):84 - 89 vol.1.
- [2] J. F. Gieras and M. Wing, Permanent Magnet Motor Technology (Design and Application). Marcel. Dekker, Inc, second edition, revised and expanded ed., 2002.
- [3] P. Pillay and R. Krisnan, “Modeling, simulation, and analysis of permanent magnet motor drives,” IEEE Trans. on Industry Application, vol. IA-25, pp. 265–279, March/April 1989.
- [4] T.-S. Low, M. A. Jabbar, and M. A. Rahman, “Permanent-magnet motors for brushless operation,” IEEE Transactions on Industry Applications, vol. 26, pp. 124–129, Jan/Feb 1990.
- [5] G. R. Slemon, “Electrical machines for variable-frequency drives,” Proceedings of The IEEE, vol. 82, pp. 1123–1139, August 1994.
- [6] T. M. Jahns, “Interior permanent-magnet synchronous motors for adjustable speed drives,” IEEE Transactions on Industry Application, vol. IA-22, pp. 738–746, July/August 1986.
- [7] T. J. E. Miller, Brushless permanent-magnet and reluctance motor drive. Oxford, London: Claredon Press, 1989.
- [8] B. Stumberger, A. Hamler, M. Trlep, and M. Jesenik, “Analysis of interior permanent magnet synchronous motor designed for flux weakening operation,” IEEE Transaction on Magnetics, vol. 37, pp. 3644–3647, September 2001.
- [9] R. F. Schiferl and T. A. Lipo, “Power capability of salient pole permanent magnet synchronous motors in variable speed drive applications,” IEEE Transactions on Industry Applications, vol. 26, pp. 115–123, January/February 1990.
- [10] Xiao Xi, Li Yongdong, and Li Min, “Performance control of PMSM drives using a self-tuning PID,” Electric Machines and Drives, 2005 IEEE International Conference on 15-18 May 2005, Page(s):1053 – 1057.
- [11] R.C Eberhart and J. Kennedy, “A new optimizer using particle swarm theory,” Proceedings of the 6th International Symposium on Micro-machine and Human Science, Nagoya, Japan, 1995, pp.39-43.
- [12] J. Kennedy and R.C. Eberhart, “particle swarm optimization,” Proceedings of IEEE International Conference on Neural Networks, Piscataway, New Jersey, USA, 1995, pp. 1942-1948.
- [13] P. Pillay, R. Krishnan: “Modeling, Simulation, and Analysis of Permanent-Magnet Motor Drives, Part I: The permanent-Magnet Synchronous Motor Drive”, *IEEE Trans. Ind. App.*, vol. 25, No. 2, pp.265-273, 1989.
- [14] B. K. Bose, Power electronics and AC drives. New York: MacGraw-Hill, 1986.
- [15] G. R. Slemon, “On the design of high-performance surface-mounted pm motors,” IEEE Transaction on Industry Application, vol. 30, pp. 134–140, January 1994.
- [16] G. R. Slemon and X. Liu, “Modelling and design optimization of permanent magnet motors,” Electric Machines and Power Systems, vol. 20, pp. 71–92, 1992.
- [17] B. P. Panigrahi and K. C. Patra, “Design of a permanent magnet synchronous motor,” Electric Machine and Power System, vol. 27, pp. 771–779, 1999.
- [18] W. L. Soong, D. A. Staton, and T. J. E. Miller, “Design of a new axially laminated interior permanent magnet motor,” IEEE Transaction on Industry Application, vol. 31, pp. 358–367, Mar/Apr 1995.

- [19] D. M. Ionel, J. F. Eastham, and T. Betzer, "Finite element analysis of a novel brushless dc motor with flux barriers," *IEEE Transaction of Magnetics*, vol. 31, pp. 3749–3751, November 1995.
- [20] O. A. Mohammed and G. F. Uler, "A hybrid technique for the optimal design of electromagnetic devices using direct search and genetic algorithms," *IEEE Transaction on Magnetics*, vol. 33, pp. 1892–1895, May 1997.
- [21] N. Bianchi, S. Bolognani, and B. J. Chalmers, "Salient-rotor pm synchronous motors for an extended flux-weakening operation range," *IEEE Transaction on Industry Application*, vol. 36, pp. 1118–1125, July/August 2000.
- [22] A. Gottvald, K. Preis, C. Magele, O. Biro, and A. Savini, "Global optimization methods for computational electromagnetic," *IEEE Transaction on Magnetics*, vol. 28, pp. 1537–1540, Mar 1992.
- [23] N. Bianchi and S. Bolognani, "Brushless dc motor design: an optimization procedure using genetic algorithms," in *Proceedings of IEE Electrical machines and drives conference*, (Cambridge, UK), pp. 16–20, IEE, September 1997.
- [24] G. F. Uler, O. A. Mohammed, and C.-S. Koh, "Utilizing genetic algorithms for the optimal design of electromagnetic devices," *IEEE Transaction on Magnetics*, vol. 30, pp. 4296–4298, November 1994.
- [25] N. Bianchi and S. Bolonani, "Design optimization of electric motors by genetic algorithms," *IEE Proceeding on Electric and Power Application*, vol. 145, pp. 475–483, September 1998.
- [26] T. Renyuan and Y. Shiyou, "Combined strategy of improved simulated annealing and genetic algorithm for inverse problem," in *10th Conference on the Computation of Electromagnetic Fields COMPUMAG'95*, (Berlin, Germany), pp. 196–197, 1995.
- [27] T. Higuchi, J. Oyama, and E. Yamada, "Optimization procedure of surface pm synchronous motors," *IEEE Transaction on Magnetics*, vol. 33, pp. 1943–1946, March 1997.
- [28] C. Schatzer and A. Binder, "Design optimization of a high-speed permanent magnet machine with the vekopt algorithms," *Industry Application Conference, IEEE*, vol. 1, pp. 439–444, 2000.
- [29] J. K. Lahteenmaki, "Optimization of high-speed motors using a genetic algorithm," *International Conference on Electric Machines and Drives, IEE*, vol. 1, pp. 26–30, September 1997.
- [30] R. Rong and D. A. Lowther, "Applying response surface methodology in the design and optimization of electromagnetic devices," *IEEE Transaction on Magnetics*, vol. 33, pp. 1916–1919, March 1997.
- [31] F. Gillon and P. Brochet, "Screening and response surface method applied to the numerical optimization of electromagnetic devices," *IEEE Transaction on Magnetics*, vol. 36, pp. 1163–1167, July 2000.
- [32] G. X. Ke, T. S. Low, L. Z. Jie, and C. S. Xin, "Robust design for torque optimization using response surface methodology," *IEEE Transaction on Magnetics*, vol. 38, pp. 1141–1144, March 2002.
- [33] Y. Fujishima, S. Wakao, A. Yamashita, and T. Katsuta, "Design optimization of a permanent magnet synchronous motor by the response surface methodology," *Journal of Applied Physics*, vol. 91, pp. 8305–8307, May 2002.
- [34] B. K. Bose, "A high-performance inverter-fed drive system of an interior pm synchronous machine," *IEEE Transaction on Industry*

- Application, vol. 24, pp. 987–997, Nov/Dec 1988.
- [35] A. B. Kulkarni and M. Ehsani, “A novel position sensor elimination technique for the interior pm synchronous motor drive,” IEEE IAS Annual Meeting Record, pp. 773–779, 1989.
- [36] G. R. Slemon, “Operating limits of inverter-driven permanent magnet motor drives,” IEEE Transaction on Industry Applications, vol. IA-23, pp. 327–32, March/April 1987.
- [37] M. N. Uddin, T. S. Radwan, G. H. George, and M. A. Rahman, “Performance of current controllers for vsi-fed ipmsm drives,” IEEE Transaction on Industry Applications, vol. 36, pp. 1531–1538, November/December 2000.
- [38] S. Morimoto, Y. Takeda, and T. Hirasa, “Current phase control methods for permanent magnet synchronous motors,” IEEE Trans. Power Electronics, vol. 5, pp. 133–139, Apr. 1990.
- [39] S. Morimoto, M. Sanada, and Y. Takeda, “Wide-speed operation of interior permanent magnet synchronous motors with high-performance current regulator,” IEEE Trans. Ind. Applicat., vol. 30, pp. 920–926, July/Aug 1994.
- [40] J. M. Kim and S. K. Sul, “Speed control of interior permanent magnet synchronous motor drive for the flux weakening operation,” IEEE Transaction on Industry Applications, vol. 33, pp. 43–48, January/February 1997.
- [41] B. J. Chalmers, “Influence of saturation in brushless permanent-magnet motor drives,” IEE Proc., vol. 139, pp. 51–52, Jan 1992.
- [42] B. J. Chalmers, R. Akmes, and L. Musada, “Validation of procedure for prediction of field-weakening performance of brushless synchronous machines,” Proc. ICEM 1998, Istanbul, Turkey, vol. 1, pp. 320–323, 1998.
- [43] E. C. Lovelance, T. M. Jahns, and J. H. Lang, “Impact of saturation and inverter cost on interior pm synchronous machine drive optimization,” IEEE Trans. Ind. Applicat., vol. 36, pp. 723–729, MAY/JUNE 2000.
- [44] A. Verl and M. Bodson, “Torque maximization for permanent magnet synchronous motors,” IEEE Trans. Contr. Syst. Technol., vol. 6, pp. 740–745, Nov. 1998.
- [45] E. Cerruo, A. Consoli, A. Raciti, and A. Testa, “Adaptive fuzzy control of high-performancemotion systems,” IEEE Proceeding of Industrial Electronics Conf. (IECON), pp. 88–94, 1992.
- [46] Z. Q. Zhu, Y. S. Chen, and D. Howe, “Online optimal flux-weakening control of permanent-magnet brushless ac drives,” IEEE Trans. on Ind. Applicat, vol. 36, pp. 1661–1668, Nov/Dec 2000.
- [47] J.-J. Chen and K.-P. Chin, “Minimum copper loss flux-weakening control of surface mounted permanent magnet synchronous motors,” IEEE Transactions on Power Electronics, vol. 18, pp. 929–936, July 2003.
- [48] L. Zhong, M. F. Rahman, W. Y. Hu, and K. W. Lim, “Analysis of direct torque control in permanent magnet synchronous motor drives,” IEEE Transaction on Power Electronics, vol. 12, pp. 528–536, May 1997.
- [49] M. F. Rahman, L. Zhong, and K. W. Lim, “A direct torque-controlled interior permanent magnet synchronous motor drive incorporating field weakening,” IEEE Transaction on Industry Application, vol. 34, pp. 1246–1253, November/ December 1998.
- [50] J. Faiz and S. H. Mohseni-Zonoozi, “A novel technique for estimation and control of stator flux of a salient-pole pmsm in dtc method based on mtpf,” IEEE Transaction on Industrial Electronics, vol. 50, pp. 262–271, April 2003

- [51] P. Vas, Sensor less Vector and Direct Torque Control. Oxford University Press, 1998.
- [52] C. Martins, X. Roboam, T. A. Meynard, and A. S. Caryalho, "Switching frequency imposition and ripple reduction in dtc drives by using a multilevel converter," IEEE Transaction on Power Electronics, vol. 17, March 2002.
- [53] C. Lascu, I. Boldea, and F. Blaabjerg, "A modified direct torque control for induction motor sensor less drive," IEEE Transaction on Industry Application, vol. 36, pp. 122–130, Jan/Feb 2000.
- [54] Ker-Wei, Yu and Shang-Chang, Hu "An application of AC servo motor by using particle swarm optimization based sliding mode controller," IEEE Conference on Systems, Man, and Cybernetics, pp. 4146-4150, October 8-11, 2006.
- [55] L. Gao, H. Gao, and C. Zhou, "Particle swarm optimization-based algorithm for machining parameter optimization," In Proceedings of the 5th World Congress on Intelligent Control and Automation, pp. 867-2871, June 15-19, 2004.

ijournals