

Speed Control of BLDC Motor Using Convention PI and Bayesian Regulation Algorithm Based Controllers

Mr. Shailesh Kumrawat¹, Mr. Pawan Pandey²

¹ M. Tech Scholar in Power Electronics, MIT, Indore (M.P). E-mail: (kumrawatshailesh@gmail.com)

² Assistant Professor & head in Electrical & Electronics Dept. MIT, Indore (M.P). E-mail: (pawanpandey@mitindore.co.in)

Abstract: BLDC motors find applications in Automotive, especially in electric vehicle (EV), appliance and industries because it does not require mechanical commutator used in traditional motors, replacing it with an electronic commutator that commutator improves the reliability and durability of the motor. Three phase voltage source inverter feeds power to the BLDC motor. It is operated by energizing two of its three phase windings at a time. This makes efficient use of windings and develops higher motor torque. The energization of the stator windings is dependent on the position of the rotor. Hall sensors are used for determining the position of the rotor. Based on the position of the rotor the switching devices in the inverter are commutated for every 60 degrees. The inverter gives desirable voltage and output frequency by controlling the switching times on or off using PWM techniques. In present work two different techniques are used for speed controlling, one is conventional PI controller-based technique and other is Bayesian regulation algorithm-based controller. The results clearly shows that Bayesian regulation algorithm-based controller has performed better than PI controller. The work is performed using MATLAB/Simulink software.

Keyword: BLDC, Bayesian regulation, PI controller, MATLAB/Simulink, Speed control.

1. Overview

Brushless DC motor is a permanent magnet synchronous motor which is powered by dc-voltage through the inverter that produces the ac electric signal to drive the motor. The torque-speed characteristics of the BLDC motor are similar to the BRUSHED DC motor, that's why the name BLDC came. The commutation is done in BLDCM is electronically instead of brushes. It is easily controlled through the rotor position sensors and performs well especially in speed/torque. With these advantages, the motor will spread to more applications. The applications of BLDCM are

increased and it is competing with the induction motors and dc motors. The output voltage and output frequency of the inverter are dependent on the switching state of the inverter.

Brushless dc (BLDC) motors are preferred as small horsepower control motors due to their high efficiency, silent operation, compact form, reliability, and low maintenance. However, the problems are encountered in these motors for variable speed operation over last decades continuing technology development in power semiconductors, microprocessors, adjustable speed drivers control schemes and permanent-magnet brushless electric motor production have been combined to enable reliable, cost-effective solution for a broad range of adjustable speed applications. Household appliances are expected to be one of fastest-growing end-product market for electronic motor drivers over the next five years. The major appliances include clothes washer's room air conditioners, refrigerators, vacuum cleaners, freezers, etc. Household appliance have traditionally relied on historical classic electric motor technologies such as single-phase AC induction, including split phase, capacitor-start, capacitor-run types, and universal motor. These classic motors typically are operated at constant-speed directly from main AC power without regarding the efficiency. Consumers now demand for lower energy costs, better performance, reduced acoustic noise, and more convenience features. Those traditional technologies cannot provide the solutions.

2. Literature review

In past many authors developed different techniques to control speed of BLDC motor, few of them has been discussed in this section:

J. A. Prakosa, et. al. in [1] discussed that Quad copter drone usually uses Brushless Direct Current (BLDC) motor as rotor due to high efficiency and small volume. The BLDC motor speed control is very important for drone position and velocity

determent. The optical sensor can be used to measure the rotation speed of BLDC motor when tested in the laboratory.

Devendra Potnuru,

et. al. in [2] discussed the rapid control prototyping implementation of closed loop speed control for a Brushless dc (BLDC) motor drive using dSPACE DS1103 controller board. Generally, control algorithms which are developed for the motor drive might show good simulation results during steady state and transient conditions; however real-time performance of the drive greatly depends on execution of real time control software, speed and position measurements and data acquisition.

H. S. Hameed in [3] discussed that Brushless DC motor has many properties including high starting torque, high efficiency, high torque, as well less electrical noise. Therefore, it is widely utilized in industrial applications. The number of controllers is presented in this paper to drive the BLDC motor.

Alejandra de la Guerra et. al. in [4] discussed that the design of an Active Disturbance Rejection Controller (ADRC) for the permanent magnet Brushless DC motor (BLDC) to compensate the load torque variations in the rotor shaft, that does not require the measurement of the rotor shaft speed.

A. Azarudeen, D. Mary in [5] discussed that paper presents the performance analysis of conventional and digital pulse width modulation (PWM) control scheme for speed control of electronically commuted trapezoidal Brushless dc (BLDC) motor. Both these methods follow the PWM speed control strategy, only difference is in the controller part. One drive system consists of conventional PI controller and the other have digital controller.

G. S. John, A. T. Vijayan in [6] discussed that the increased use of variable speed drive systems in small scale and large-scale applications like automobile industries, medical equipment and household appliances led to the development of BLDC motor. BLDC drives have various advantages like higher efficiency, better speed-torque characteristics high power density and low maintenance over other conventional motors.

Grepl R., Ryszard Jabłoński, Tomas Brezina in [7] discussed that the application of Extended Kalman Filter to the speed control of a BLDC motor. The inputs to EKF are computed based on the measured data as well as the disturbance (an external mechanical load).

J. Weirong, H. Haibo, L. Jianping in [8] discussed that the classical PID cannot adapt to the dynamic

characteristics of the brushless DC motor, integral separation fuzzy control combined with classical PI is put forward to build up brushless DC motor speed current double closed-loop control system. Among them, the speed outer loop uses integral separation fuzzy PI control; the current inner loop uses integral separation PI control.

S. Yaya, W. Honghua in [9] discussed that the increase use of variable-speed drive motors to reduce energy consumption will require a shift from PID controllers to system based on fuzzy logic algorithms to simplify design, reduce development time, and eliminate complex math formulas.

Alireza Shabani, et. Al. in [10] discussed that presents a method for the optimal design of a slot less permanent magnet brushless DC (BLDC) motor with surface mounted magnets using an improved bee algorithm (IBA). The characteristics of the motor are expressed as functions of motor geometries. The objective function is a combination of losses, volume and cost to be minimized simultaneously.

Debjyoti Chowdhury, Madhurima Chattopadhyay, Priyanka Roy in [11] discussed that deals with a new commutation approach to achieve the sensorless drive of permanent magnet BLDC motor over the conventional six switch commutation circuitry. In the simulation model, we have introduced four switch three phase Brushless DC (BLDC) motor drive in which the rotor position is estimated using back EMF detection technique.

Madhurima Chattopadhyay et. al. in [12] discussed that a simulation model has been developed in this paper to study the behavioral characteristic of Brushless DC motor and also analyses the harmonics present in the stator current, rotor speed and acceleration of the BLDC drive circuit. Hence in order to improve the accuracy of the motor drive control system, we have introduced a denoising module in the feedback path.

J. Bernat, S. Stepien in [13] discussed a new adaptive speed controller for the brushless DC motor. The methodology of model reference adaptive control is applied to a novel model of BLDC motor. This novel model provides the possibility to compensate the torque ripples and load torque. The system stability is proven using Lapunov function.

U. Vinatha in [14] discussed that BLDC motors have been gaining attention from various industrial and household appliance manufacturers, because of its high efficiency, high power density and low

maintenance cost. After many research and developments in the fields of magnetic materials and power electronics, their applications to electric drives have increased to a significant extent.

P. Suganthi in [15] discussed that BLDC motors characterized as permanent magnet synchronous motors. Since it has its own unique characteristics such as long life, good efficiency, remarkable starting torque, it has gained good momentum in market hence it is widely used in leading automobile industries.

3. Principle operation of BLDC motor

The principal operation of BLDC motor and Brushed DC motor is same. In Brushed DC motor the feedback is mechanical commutator, but in BLDC motor the feedback is given feedback sensors which are hall sensors or optical encoders.

The principle of the hall sensors is that whenever a current carrying conductor is placed in the magnetic field it produces a force so that the emf induced on the two sides of the conductors. The hall sensors placed in the stator of the BLDC motor gives low or high signal when the rotor rotates and moves near to the sensor, which gives the position of the rotor.

The DC voltage is applied to the motor through three phase voltage source inverters (VSI), so that the stator coils are excited and due to the interaction of stator flux and the rotor flux the stator starts rotating. To maintain this rotation the orientation of the magnetic field should be rotated sequentially in either clockwise direction or in anti-clockwise direction.

4. PID Controller Design

PID (proportional integral derivative) control is one of the prior control techniques. Its initial execution was in pneumatic gadgets, trailed by vacuum and solid-state analog electronics, before showing up at the present computerized usage of microchips. It has a basic control structure which was comprehended by plant administrators and which they discovered generally simple to tune. It is a conventional control circle input instrument and utilized as a criticism controller. PID's working guideline is that it computes a mistake an incentive from the handled estimated esteem and the ideal reference point.

$$\frac{n(s)}{e(s)} = G_c(s) = K_p \left(1 + \frac{1}{T_i s} + T_d s \right) \quad (1)$$

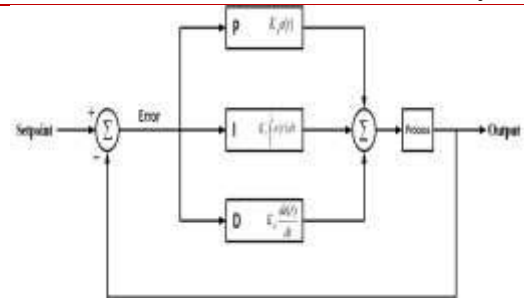

Figure 1: Block Diagram of the PID controller

5. Bayesian Regularization (BR) Algorithm:

BRANNs are extra vigorous than usual back-propagation networks and can lessen the necessity for long cross-validation. BR algorithm is a process that changes a nonlinear regression into a “well-modelled” statistical problem in the means of a ridge regression. In this algorithm regularization is used to improve the network by optimizing the performance function $F(\omega)$. The performance function $F(\omega)$ is the sum of the squares of the errors of the network weights (E_w) and the sum of squares error of the data (E_D) [30].

$$F(\omega) = \alpha E_w + \beta E_D \quad (2)$$

Where,

$$E_D = \sum_{k=1}^n e_k^2 \quad (3)$$

$$E_w = \sum_{i=1}^n w_i^2 \quad (4)$$

where α and β denotes objective function values. Bayesian Regularization is a training algorithm that updates the values of weights and bias according to LM optimization [31]. In Bayesian Regularized training algorithm, the weights of the models are considered as random initially, and then the value of the network weights and training set are reproduced using Gaussian distribution. The α and β parameters are calculated using the Bayes' theorem,

$$\alpha = \frac{\gamma}{2 E_w} \quad (5)$$

$$\beta = \frac{N_D - \gamma}{2 E_D} \quad (6)$$

$$\gamma = \sum_{i=1}^{N_w} \frac{\lambda_i}{\lambda_i + \alpha} \quad (7)$$

N_D is the number of data points, N_w is number of weights, λ_i is eigen values of the data Hessian and

Y is the effective number of parameters necessary for the model.

6. Result and Discussion

6.1 Speed control of BLDC motor using PI controller

In the previous section, a detailed discussion about proposed methodology is done. In present section those methods are implemented and results are obtained after simulation. This section will deal with speed torque response using PI controller for BLDC motor.

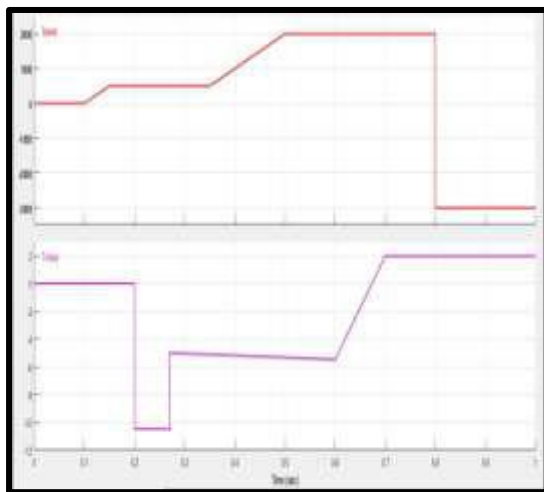

Fig 2 speed torque reference value

Figure 2 shows the reference value of speed and torque take into consideration. The response of drive will be noted based on this value.

Fig 3 shows the Simulink model of speed control of BLDC motor using PI controller. The model is mainly comprised of speed controller, voltage controller, BLDC motor, DC-DC converter and 3phase inverter.

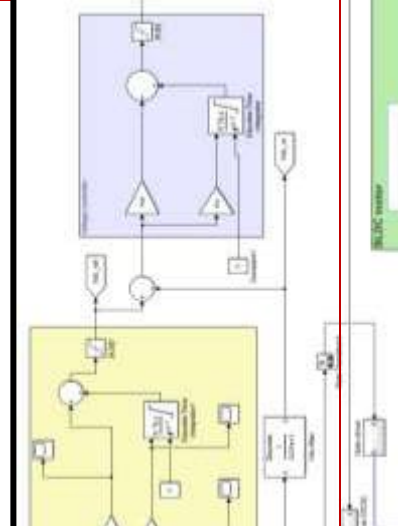

Fig 3 Simulink model of speed control of BLDC motor using PI controller

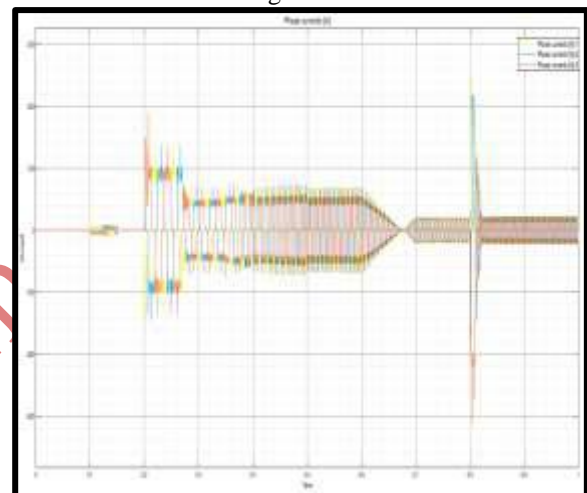

Fig 4 Three phase current response from Invertor for PI controller

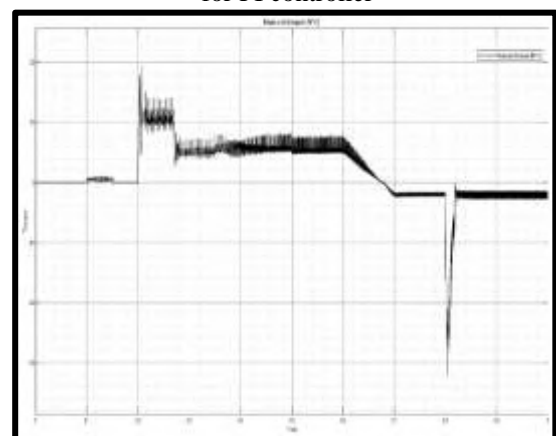

Fig 5 Measured torque response for PI controller

Figure 4 shows the output waveform of phase currents using PI controller. Figure 5.4 shows the torque response of discussed model for PI controller.

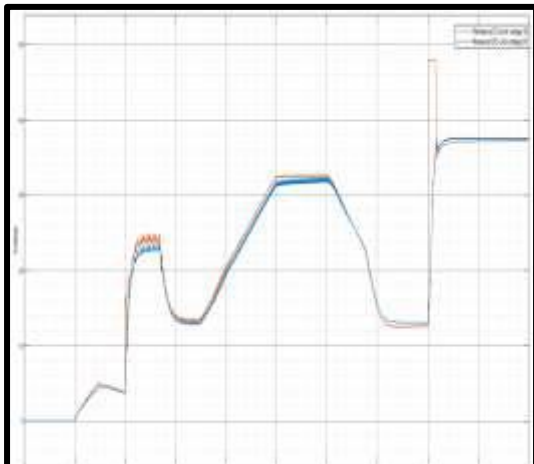

Fig 6 reference and measured DC-link Voltage for PI controller

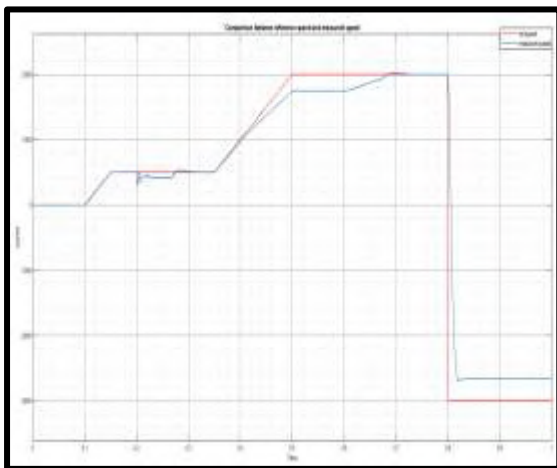

Fig 7 Measured and reference Speed vs. Time of a BLDC motor for PI controller

Figure 6 shows a comparative plot of reference and measure DC link voltage for PI controller. Figure 7 presents a comparative plot of reference and measured speed with the help of conventional controllers for dissed reference input speed and torque requirement.

5.2 Speed control of BLDC motor using Bayesian regulation controller

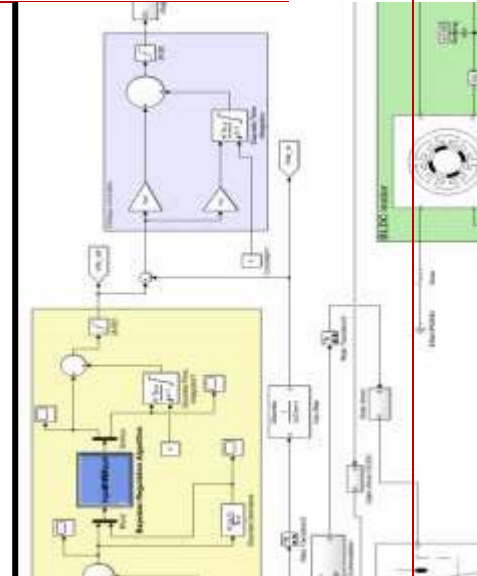

Fig 8 Simulink model of speed control of BLDC motor using Bayesian Regulation based controller

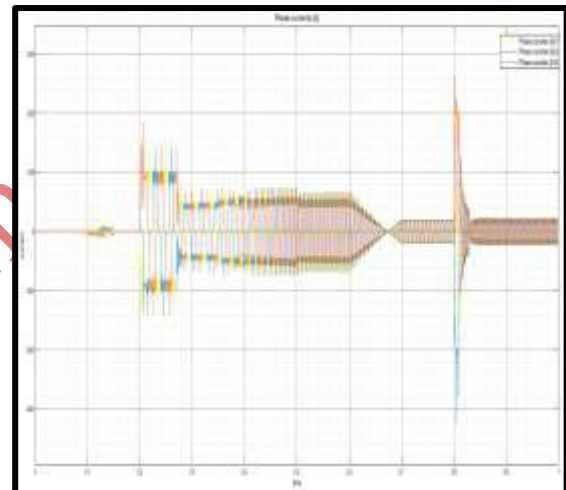

Fig 9 Three phase current response from Invertor for BR based controller

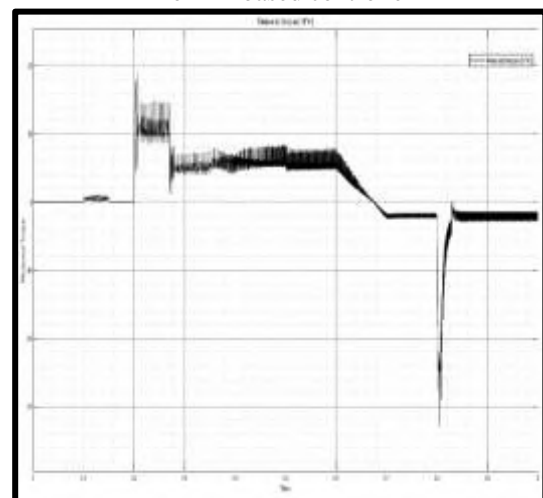

Fig 10 Measured torque response for BR based controller

Figure 9 shows the output waveform of phase currents using BR based controller. Figure 10 shows the torque response of discussed model for BR based controller.

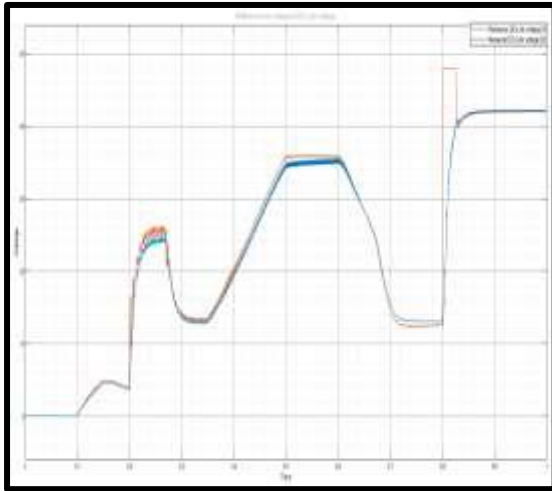

Fig 11 reference and measured DC-link Voltage for BR based controller

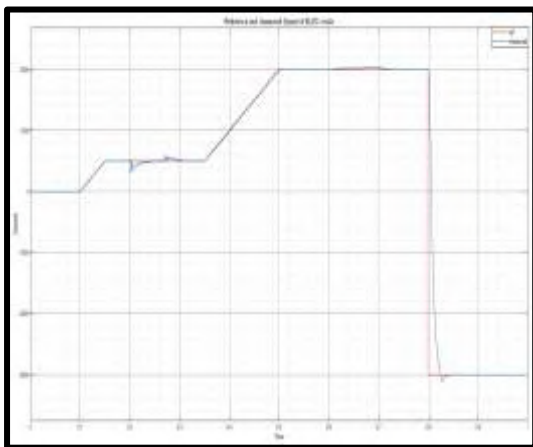

Fig 12 Measured and reference Speed response of a BLDC motor for Bayesian Regulation based controller

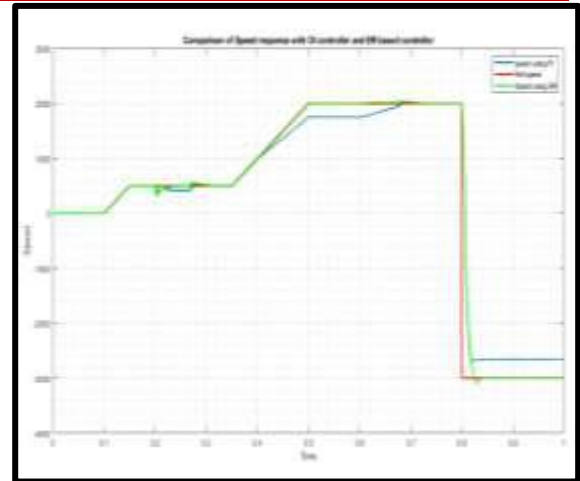

Fig13 Comparison of speed response with PI controller and BR based controller

Figure 11 shows a comparative plot of reference and measure DC link voltage for Bayesian Regulation based controller. Figure 12 presents a comparative plot of reference and measured speed with the help of conventional controllers for dissed reference input speed and torque requirement using Bayesian Regulation based controller

Figure 13 shows the comparative plot of 3 signals. Red colour line is response signal for speed. Blue colour line is for speed response using PI controller. Green colour line is for BR algorithm-based controller. The figure clearly shows the BR based follow reference line in far better manner than the conventional PI controller

7. Conclusion

In this thesis a closed loop speed control of BLDC motor drive BR algorithm-based controller is carried out and it is compared with PI controller fed BLDC drive. Simulation results show that current ripple and torque ripple are minimized which enhance the performance of the drive. By comparing the performances of Permanent magnet brushless dc motor with BR and PI controller, it is concluded that applying the load torque to the motor with conventional controller, motor speed will be decreased and it should regain its speed quickly. The Rise time of BR controller is better than PI controller. With BR controller, BLDC motor has low steady state error while with PI controller; there is some steady state error. Hence BR based controller gives high efficiency. The results show that the dynamic performance of the motor is quite satisfactory for various loading conditions. The actual tuning of the controller only involves minimal effort. The motor displays good tracking performance for different speed trajectories. The robustness of the controller is positively established by evaluating its

performance under noisy loading conditions. The controller remains stable for a wide range of sampling frequencies.

References

- [1] J. A. Prakosa, D. V. Samokhvalov, G. R. V. Ponce, and F. S. Al-Mahturi, "Speed Control of Brushless DC Motor for Quad Copter Drone Ground Test," in *2019 IEEE Conference of Russian Young Researchers in Electrical and Electronic Engineering (EIConRus)*, Jan. 2019, pp. 644–648, doi: 10.1109/EIConRus.2019.8656647.
- [2] D. Potnuru, A. M. K., and S. Ch., "Design and implementation methodology for rapid control prototyping of closed loop speed control for BLDC motor," *J. Electr. Syst. Inf. Technol.*, vol. 5, no. 1, pp. 99–111, May 2018, doi: 10.1016/j.jesit.2016.12.005.
- [3] H. S. Hameed, "Brushless DC motor controller design using MATLAB applications," in *2018 1st International Scientific Conference of Engineering Sciences - 3rd Scientific Conference of Engineering Science (ISCES)*, Jan. 2018, pp. 44–49, doi: 10.1109/ISCES.2018.8340526.
- [4] A. de la Guerra, L. Alvarez-Icaza, and L. Torres, "Brushless DC motor control with unknown and variable torque load," *IFAC-Pap.*, vol. 51, no. 13, pp. 644–649, Jan. 2018, doi: 10.1016/j.ifacol.2018.07.353.
- [5] A. Azarudeen and D. Mary, "Performance analysis of conventional and digital PWM control scheme for speed control of BLDC motor drives," in *2017 International Conference on Advances in Electrical Technology for Green Energy (ICAETGT)*, Sep. 2017, pp. 69–75, doi: 10.1109/ICAETGT.2017.8341460.
- [6] G. S. John and A. T. Vijayan, "Anti-windup PI controller for speed control of brushless DC motor," in *2017 IEEE International Conference on Power, Control, Signals and Instrumentation Engineering (ICPCSI)*, Sep. 2017, pp. 1068–1073, doi: 10.1109/ICPCSI.2017.8391874.
- [7] H. Z., S. V., and G. R., "Sensorless Speed Control of BLDC Motor using EKF with Computed Inputs and Disturbance," in *Advanced Mechatronics Solutions*, Cham, 2016, pp. 45–50, doi: 10.1007/978-3-319-23923-1_7.
- [8] J. Weirong, H. Haibo, and L. Jianping, "Simulation and Design of Integral Separation Adaptive Fuzzy Control System for Brushless DC Motor," in *2013 International Conference on Computational and Information Sciences*, Jun. 2013, pp. 1194–1197, doi: 10.1109/ICCIS.2013.316.
- [9] S. Yaya and W. Honghua, "Research on Reduction of Commutation Torque Ripple in Brushless DC Motor Drives Based on Fuzzy Logic Control," in *2009 International Conference on Computational Intelligence and Security*, Dec. 2009, vol. 1, pp. 240–243, doi: 10.1109/CIS.2009.158.
- [10] A. Shabaniyan, A. A. P. Tousiwas, M. Pourmandi, A. Khormali, and A. Ataei, "Optimization of brushless direct current motor design using an intelligent technique," *ISA Trans.*, vol. 57, pp. 311–321, Jul. 2015, doi: 10.1016/j.isatra.2015.03.005.
- [11] D. Chowdhury, M. Chattopadhyay, and P. Roy, "Modelling and Simulation of Cost Effective Sensorless Drive for Brushless DC Motor," *Procedia Technol.*, vol. 10, pp. 279–286, Jan. 2013, doi: 10.1016/j.protcy.2013.12.362.
- [12] M. Chattopadhyay, P. Roy, and S. Dutta, "Simulation Modeling of BLDC Motor Drive and Harmonic Analysis of Stator Current, Rotor Speed and Acceleration using Discrete Wavelet Transform Technique," *Procedia Technol.*, vol. 4, pp. 666–670, Jan. 2012, doi: 10.1016/j.protcy.2012.05.107.
- [13] J. Bernat and S. Stepien, "The adaptive speed controller for the BLDC motor using MRAC technique," *IFAC Proc. Vol.*, vol. 44, no. 1, pp. 4143–4148, Jan. 2011, doi: 10.3182/20110828-6-IT-1002.01497.
- [14] U. Vinatha, S. Pola and K. P. Vittal, "Simulation of four quadrant operation & speed control of BLDC motor on MATLAB / SIMULINK," *TENCON 2008 - 2008 IEEE Region 10 Conference*, Hyderabad, India, 2008, pp. 1-6, doi: 10.1109/TENCON.2008.4766449.
- [15] P. Suganthi, S. Nagapavithra and S. Umamaheswari, "Modeling and simulation of closed loop speed control for BLDC motor," *2017 Conference on Emerging Devices and Smart Systems (ICEDSS)*, Tiruchengode, 2017, pp. 229–233, doi: 10.1109/ICEDSS.2017.8073686.
- [16] H. Wu, M. Wen and C. Wong, "Speed control of BLDC motors using hall effect sensors based on DSP," *2016 International Conference on System Science and Engineering (ICSSE)*, Puli, Taiwan, 2016, pp. 1-4, doi: 10.1109/ICSSE.2016.7551633.
- [17] N. Samoylenko, Q. Han and J. Jatskevich, "Improving Dynamic Performance of Low-Precision Brushless DC Motors with Unbalanced Hall Sensors," *2007 IEEE Power Engineering Society General Meeting*, Tampa, FL, USA, 2007, pp. 1-8, doi: 10.1109/PES.2007.386221.
- [18] X. Zhang, L. Sun, K. Zhao and L. Sun, "Nonlinear Speed Control for PMSM System Using Sliding-Mode Control and Disturbance Compensation Techniques," in *IEEE Transactions on Power Electronics*, vol. 28, no. 3, pp. 1358–1365, March 2013, doi: 10.1109/TPEL.2012.2206610.
- [19] H. Liu and S. Li, "Speed Control for PMSM Servo System Using Predictive Functional Control and Extended State Observer," in *IEEE Transactions on Industrial Electronics*, vol. 59, no.

- 2, pp. 1171-1183, Feb. 2012, doi: 10.1109/TIE.2011.2162217.
- [20] S. Singh and A. N. Tiwari, "Various techniques of sensorless speed control of PMSM: A review," 2017 Second International Conference on Electrical, Computer and Communication Technologies (ICECCT), Coimbatore, 2017, pp. 1-6, doi: 10.1109/ICECCT.2017.8117995.
- [21] Danyang Bao, Xuwei Pan, Yi Wang, Xinshuo Wang, Ke Li, "Adaptive Synchronous-Frequency Tracking-Mode Observer for the Sensorless Control of a Surface PMSM", *Industry Applications IEEE Transactions on*, vol. 54, no. 6, pp. 6460-6471, 2018.
- [22] Shweta Singh, Amjad Anvari-Moghaddam, "Sensor-based and Sensorless Vector Control of PM Synchronous Motor Drives: A Comparative Study", *Power Electronics Conference (SPEC) 2018 IEEE 4th Southern*, pp. 1-6, 2018.
- [23] Nitesh Tiwari, A. N. Tiwari, "Design and Control of Buck Converter using PID and Fuzzy Logic Controller", *Power Energy Environment and Intelligent Control (PEEIC) 2018 International Conference on*, pp. 557-564, 2018.
- [24] Hao Lin, Abraham Marquez, Feng Wu, Jianxing Liu, Hao Luo, Leopoldo G. Franquelo, Ligang Wu, "MRAS-Based Sensorless Control of PMSM with BPN in Prediction Mode", *Industrial Electronics (ISIE) 2019 IEEE 28th International Symposium on*, pp. 1755-1760, 2019.
- [25] Shadab Murshid, Bhim Singh, "Energy-efficient single-stage solar PV powered sensorless PMSM drive for water pumping", *Renewable Power Generation IET*, vol. 13, no. 13, pp. 2267-2277, 2019.
- [26] Jarosław Guziński, Marcin Morawiec, Zbigniew Krzemiński, Krzysztof Łuksza, Patryk Strankowski, Abdellah Kouzou, "Sensorless Low Speed PMSM Motor Control with Cogging Torque Compensation", *Smart Grid and Renewable Energy (SGRE) 2019 2nd International Conference on*, pp. 1-6, 2019.
- [27] Shadab Murshid, Bhim Singh, "An Improved SMO for Position Sensorless Operation of PMSM Driven Solar Water Pumping System", *Power Electronics Smart Grid and Renewable Energy (PESGRE2020) 2020 IEEE International Conference on*, pp. 1-5, 2020.
- [28] Shadab Murshid, Bhim Singh, "Reduced Sensor-Based PMSM Driven Autonomous Solar Water Pumping System", *Sustainable Energy IEEE Transactions on*, vol. 11, no. 3, pp. 1323-1331, 2020.
- [29] M P Srinivasan, Alivelu Manga Parimi, "Solar Powered Permanent Magnet Synchronous Motor Drive for Water Pumping Applications", *Emerging Technology (INCET) 2020 International Conference for*, pp. 1-6, 2020.
- [30] Irfan Sami, Shafaat Ullah, Abdul Basit, Nasim Ullah, Jong-Suk Ro, "Integral Super Twisting Sliding Mode Based Sensorless Predictive Torque Control of Induction Motor", *Access IEEE*, vol. 8, pp. 186740-186755, 2020.
- [31] Zhihao Song, Wenxi Yao, Kevin Lee, "A V/Hz based Maximum Torque per Volt Control in Flux-Weakening Region for Interior Permanent Magnet Synchronous Motors", *Energy Conversion Congress and Exposition (ECCE) 2020 IEEE*, pp. 2740-2745, 2020.
- [32] Sachin Patel, Vinod Patel, Chanakya Bhatt, "Implementation of Sensorless Vector Control PMSM Drive for Electrical Vehicle Application", *Power and Renewable Energy Conference (IPRECON) 2020 IEEE International*, pp. 1-6, 2020.