

PAPR Reduction for OFDM systems using Modified Selective Mapping

Authors: Mr. Chetan Tomar¹; Dr. Amit Udawat²

¹Research scholar, ECE department, SKITM, Indore (chetansinghtomar01@gmail.com)

²Hod, ECE department, SKITM, Indore (amitudawat@skitm.in)

Abstract—The need for advanced multiplexing techniques has remained a serious challenge with increased bandwidth requirement. With increasing number of users, large data being generated and limited bandwidth available for systems, efficient multiplexing techniques are needed that use the available bandwidth efficiently. One of the most efficient multiplexing techniques available is the Orthogonal Frequency Division Multiplexing (OFDM). It is widely used in WAN based applications. One of the major challenges that OFDM suffers from is high value of Peak to Average Power Ratio (PAPR). This causes high Bit Error Rates and reduced Quality of Service. The proposed work uses a modified selective mapping technique and attains lower PAPR compared to previously existing work.

Keywords:-

OFDM, PAPR-, High Power Amplifier, Clipping, Filtering SLM, PTS, Companding, Interleaving, Bit Error Rate (BER).

I. INTRODUCTION

Orthogonal Frequency Division Multiplexing or OFDM is a technique that works on the principle of orthogonality. The carriers or signals are mutually orthogonal and hence create no overlap. Using OFDM in place of FDM helps in accommodating more users or devices in the same available bandwidth.

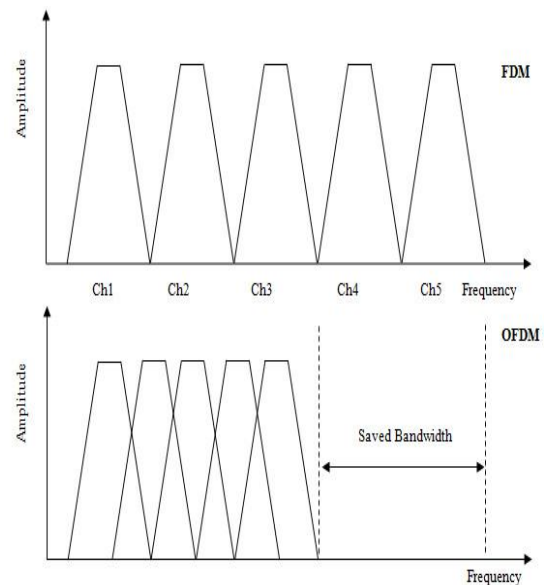

Fig.1 Comparative Analysis of FDM and OFDM.

The major advantages of this technique are high spectral efficiency and efficient digital implementation. The drawback lies in the fact that the amplitude variations of OFDM signals is large, which requires large back-off in the transmitter amplifier and hence High Power Amplifiers (HPAs) are not efficiently used. In order to reduce the distortion caused by a HPA without setting it to large back-offs, several techniques have been introduced that limit the peak of the envelope of the signal (clipping)[1],[5], a problem that is usually referred to as peak-to-average power ratio (PAPR) reduction. These techniques have varying PAPR-reduction capabilities, power, and bandwidth and complexity requirements. PAPR is a very well-known measure of the envelope fluctuations of a multicarrier (MC) signal and plays a decisive role in the adoption of any particular technique. So the major problem with OFDM is high peak to power ratio or PAPR

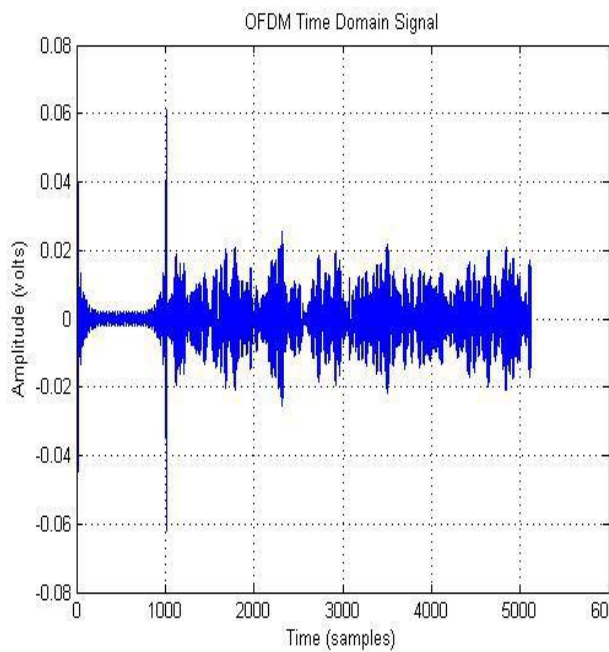

Fig.2 OFDM Time Domain Signal

The graph above shows the time domain OFDM signal. It can be seen that the signal has high peaks leading to high peak to average power ratio defined by:

$$PAPR = \max \{x^2(t)\} / \text{mean}\{x^2(t)\} \quad (1)$$

Where $x(t)$ denotes the time domain OFDM signal. The Complementary Cumulative Distribution Function (CCDF) is often used to analyze the magnitude of PAPR in an OFDM system, which is mathematically defined as:

$$\text{Probability (PAPR } \{x\} > Y) = 1 - (1 - e^{-Y})^N \quad (2)$$

Here N is the number of sub-carriers, Y is any arbitrary value of PAPR above which the possibility of attaining PAPR is evaluated. The CCDF plot clearly indicates the possibility of attaining PAPR greater than a particular PAPR value. Since the user data is random in nature, hence the modulated version of the OFDM signal is also random in nature. Hence probabilistic approaches need to be used for the analysis of PAPR.

II. SELECTIVE MAPPING

Selective mapping is the most fundamental and highly efficient technique to reduce PAPR. It

provides a high performance as compared to normal OFDM. In this method set of m different symbols are generated of the same signal X and out of these m symbols the symbol with minimum PAPR is transmitted, which is given by:

$$\text{Min}\{PAPR(x(t)^m)\} \quad (3)$$

The block diagram of the SLM technique is given below:

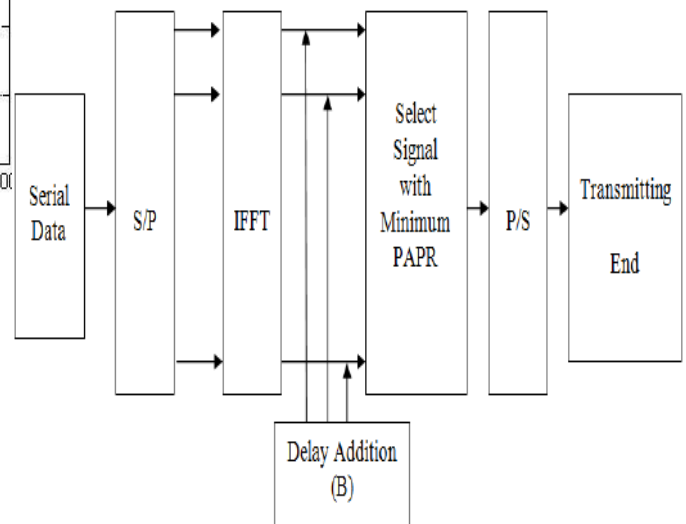

Fig.3 Block Diagram of SLM Technique

The only disadvantage of SLM can be thought to be the increase in complexity in case more delay vectors are added which eventually increases the searching complexity. Each X block contain N wide variety of binary information, and those blocks are improved by means of one-of-a-kind phase sequence. These exclusive segment collection are termed as M . After multiplying with M distinctive stages a very changed information movement is acquired. This changed statistics circulate is implemented to the IDFT block which generates mutually orthogonal sub carriers and those sub carriers are modulated via the records movement. With out the IDFT blocks, N nearby oscillators could be wanted for generating N together orthogonal sub carriers which might in turn boom the complexity and electricity consumption of the gadget whilst making it cumbersome. The larger the wide variety of levels introduced, i.e. the bigger the period of the segment vector, extra is the PAPR discount capability.

III. MODIFIED SELECTIVE MAPPING

In the proposed selective mapping technique, the signal received after the selective mapping technique is analysed and residual peaks are found. The residual peaks are multiplied with an inverse sync function so as to reduce the residual peaks. The flowchart of the proposed system is shown below.

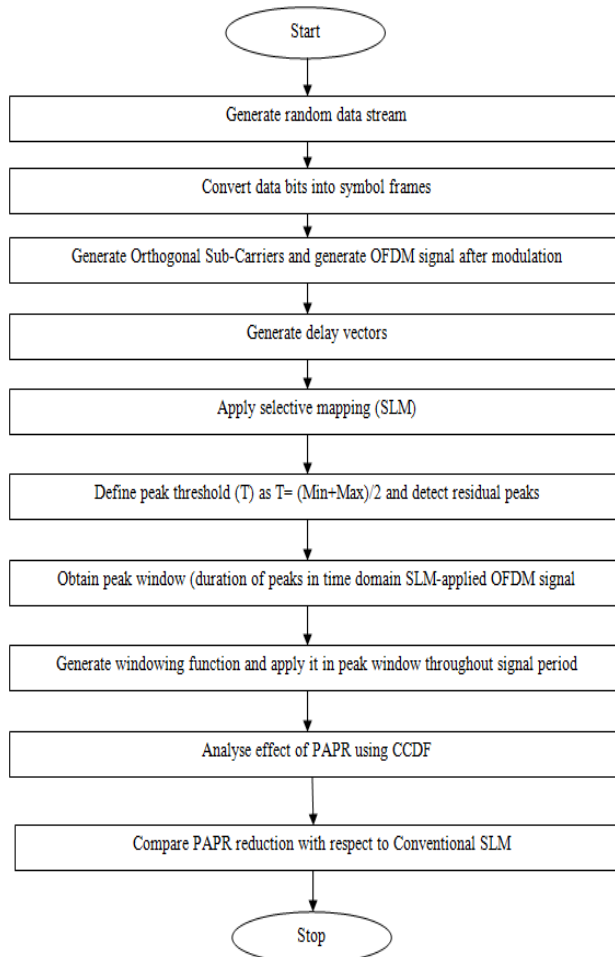

Fig.4 Flowchart of Proposed Technique

In the proposed scheme, an inverse sync window is multiplied with the residual peaks of the signal after SLM is applied. The inverted sync is chosen since it resembles the inverted peaks of a typical time domain OFDM signal. The inverted sync function is defined as:

$$W=1-\text{sinc}(m)/\pi^2.m^2 \quad (5)$$

The inverted sync function is shown in the figure below:

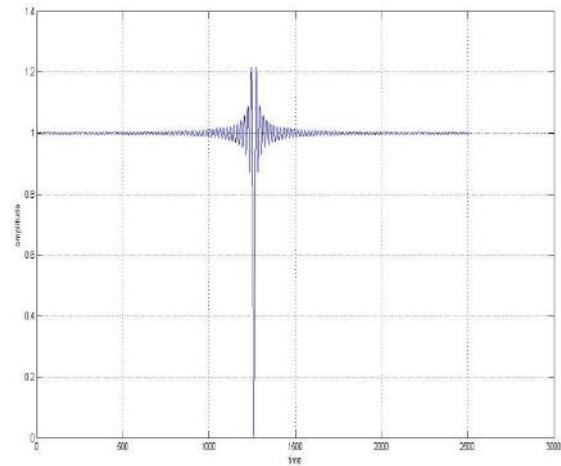

Fig.5 Inverted sync windowing function.

IV. RESULTS

The results are analyzed using the CCDF curve and an earlier plummet or fall in the CCDF curve among two systems indicates that the PAPR has been reduced in the one with an earlier fall of CCDF or PAPR.

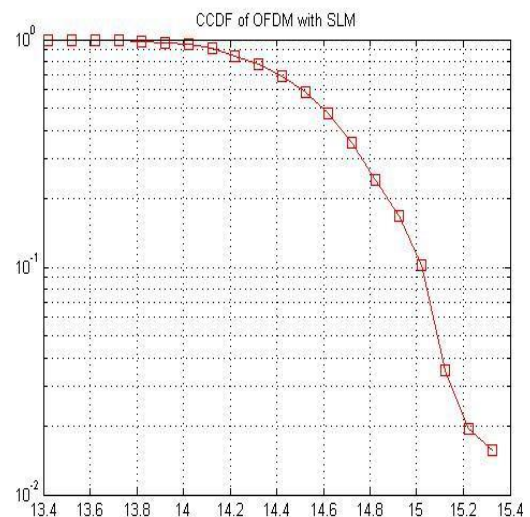

Fig.6 CCDF of Conventional SLM

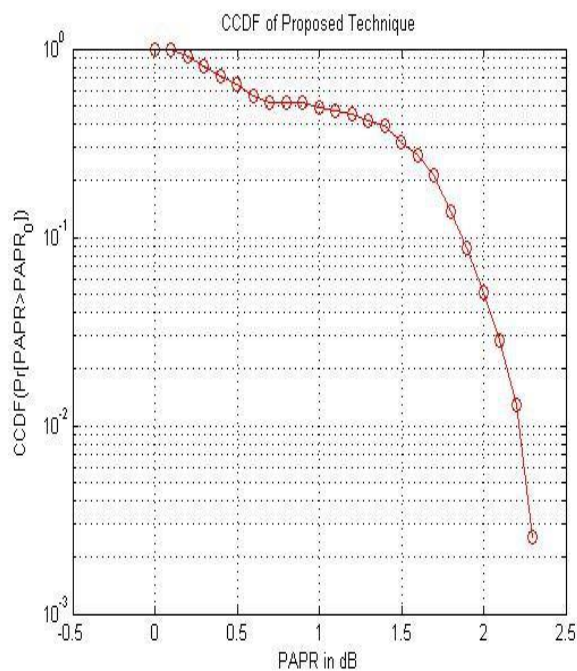

Fig.7 CCDF Proposed Technique

CONCLUSION

It can be concluded from the previous discussions and supporting results that the proposed technique is effective in reduction of OFDM based data transmission. A modification to the selective mapping technique has been proposed so as to reduce the PAPR of the system. The peak windowing and SLM have been combined to identify residual peaks after SLM alone is applied. The CCDF has been used for the analysis of the PAPR of the system. It can be seen from the results that the proposed system attains extremely low values of PAPR for OFDM systems

REFERENCES

[1] Z. Xing, K. Liu, A. S. Rajasekaran, H. Yanikomeroglu and Y. Liu, "A Hybrid Companding and Clipping Scheme for PAPR Reduction in OFDM Systems," in IEEE Access, vol. 9, pp. 61565-61576, 2021

[2] S. Thota, Y. Kamatham and C. S. Paidimarry, "Analysis of Hybrid PAPR Reduction Methods of OFDM Signal for HPA Models in Wireless Communications," in IEEE Access, vol. 8, pp. 22780-22791, 2020

[3] S. Thota, Y. Kamatham and C. S. Paidimarry, "Analysis of Hybrid PAPR Reduction Methods of OFDM Signal for HPA Models in Wireless

Communications," in IEEE Access, vol. 8, pp. 22780-22791, 2019

[4] Chongfu Zhang ,Wei Zhang , Xiujun He , Chen Chen ; Huijuan Zhang ; Kun Qiu, , "Physically Secured Optical OFDM-PON by Employing Chaotic Pseudorandom RF Subcarriers", IEEE 2017

[5] Wei Zhang ,Chongfu Zhang ,Chen Chen ,Wei Jin ,Kun Qiu, "Joint PAPR Reduction and Physical Layer Security Enhancement in OFDMA-PON",IEEE 2016

[6] Wei Zhang ,Chongfu Zhang ,Wei Jin ,Kun Qiu ,Chen Chen," Hybrid time-frequency domain chaotic interleaving for physical-layer security enhancement in OFDM-PON systems", IEEE 2016

[7] Xiaonan Hu , Xuelin Yang , Zanwei Shen ,Hao He ,Weisheng Hu ,Chenglin Bai," Chaos-Based Partial Transmit Sequence Technique for Physical Layer Security in OFDM-PON",IEEE 2015

[8] Xuelin Yang , Xiaonan Hu ,Zanwei Shen ,Hao He ,Weisheng Hu ,Chenglin Bai, "Chaotic signal scrambling for physical layer security in OFDM-PON",IEEE 2015

[9] Bo Liu ,Lijia Zhang ,Xiangjun Xin ,Yongjun Wang," Physical Layer Security in OFDM-PON Based on Dimension-Transformed Chaotic Permutation", IEEE 2014

[10] Wei Zhang ; Chongfu Zhang ; Wei Jin ; Chen Chen ; Ning Jiang ; Kun Qiu," Chaos Coding-Based QAM IQ-Encryption for Improved Security in OFDMA-PON", IEEE 2014

[11] Yong Tao ; Lingchen Huang ; Biao Chen," Secure communication in an OFDM-PON system by using frequency hopping",IEEE 2013

[12] Ning Jiang ; Ding Liu ; Chongfu Zhang ; Kun Qiu, ," Modeling and Simulation of Chaos-Based Security-Enhanced WDM-PON", IEEE 2013

[13] Elaine Wong," Next-Generation Broadband Access Networks and Technologies", IEEE 2012

[14] Neda Cvijetic, "Recent progress in DSP-based optical access and OFDMA-PON", IEEE 2012

[15] Lijia Zhang ; Xiangjun Xin ; Bo Liu ; Yongjun Wang, "Secure OFDM-PON Based on Chaos Scrambling", IEEE 2011

[16] Arsenia Chorti ; H. Vincent Poor, "Faster than Nyquist interference assisted secret communication for OFDM systems", IEEE 2011

[17] H. Li, T. Jiang and Y. Zhou, "An Improved Tone Reservation Scheme With Fast Convergence for PAPR Reduction in OFDM Systems," in IEEE Transactions on Broadcasting, vol. 57, no. 4, pp. 902-906, Dec. 2011.

[18] H. Jeon, J. No and D. Shin, "A Low-Complexity SLM Scheme Using Additive Mapping Sequences for PAPR Reduction of OFDM Signals," in IEEE Transactions on Broadcasting, vol. 57, no. 4, pp. 866-875, Dec. 2011.