

A SURVEY ON RAIL TRACK INSPECTION METHODS

A.Indhuja¹, C.Ranjani²

PG scholar¹, Assistant Professor²

Department of Computer Science and Engineering^{1,2}

Sri Ramakrishna Engineering College^{1,2}

Indhujanandan1494@gmail.com¹, ranjini.c@srec.ac.in²

ABSTRACT

Rail track monitoring is an emerging system, which is being adopted and supported by many countries across the world. In-service rail track monitoring and fault reporting refers to the inspection of the track frequently and intimates the fault to responsible person to provide service at the right time. The proposed system explains the automatic control of the gates at the railway crossing in order to reduce the traffic jam occurred near the level crossing. This system provides the exact location of the fault by enabling GPS and intimates the fault to the highest authority using GSM or Wi-Fi module. When deployed, this reduces the human hurdles of operation, increases consistency and prevents accidents at railway level crossing. It also avoids human intervention and manual errors since the quality of the result depend upon the workers.

Keywords: Track inspection, In-service, Monitoring

1. INTRODUCTION

Rail track is one of the most important infrastructures for the rail transport and plays a vital role for the safe and comfort journey of the passengers. Monitoring of railway tracks routinely is essential in ensuring the safety of railway system. Poor track management leads to degradation in the quality of ride, flange contact, flange climb, finally leads to the derailment.



Fig 1. Railway Track

There are two main methods for inspecting the track condition. One is portable devices which involves engineer's assistance to operate along the track line during the midnight. It's a time consuming work and the accuracy of the result is not guaranteed since it depends on the ability of the workers. Another one is the Track Recording Vehicle (TRV) for scrutinizing the geometry condition of the track, which uses many acceleration sensors, optical sensors, and gyro sensors for measuring the different irregularities, such as vertical unevenness, gauge, lateral alignment, cross level, and twist. However, such a system is expensive and the optical sensors are very much sensitive to the harsh environment. In addition, TRV can only carry out the inspection in the midnight (off duty). The track will be inspected only once or less in a month. The dreadful track degradation cannot be detected immediately and there is potential safety threat for the journey of the passengers.

2. LITERATURE SURVEY

The track inspection method presented in [9] is directly related to the suspension system of the railway vehicles since the irregularities of the tracks are measured by the sensors which is mounted on the vehicle body. The sensors used for measuring the vehicle dynamical response are only acceleration sensors. On the car body floor, four acceleration sensors are installed which are just above one side of the bogie frame and beside the air springs. For each bogie, four acceleration sensors are equipped in the bogie frame sides facing to outside and two are in the front and the other two are in the rear. Each sensor can measure both the vertical acceleration and lateral acceleration of the bogie frame. The acceleration signal can be transformed to displacement signal by applying double integral to the acceleration signal. The data acquisition device samples the signal from the sensor and sends the data to the processing device where the track alignments are estimated by double integrating the filtered data. The estimated track alignments are further assessed by using a track

geometry deviation standard. The data acquisition system can save the sampling data for 8 hours.

The method explained in [1] projects that the data can be collected more frequently even during day-to-day activity, related to the current condition of the track. In addition, the development of the proper data management and analysis can give a detailed description of the track line status, especially concerning rail defects and in general, short-pitch corrugation. Corrugation is one of the major sources of noise and vibrations transmitted to the buildings surrounding the subway lines, and a proper grinding program up to now is the most effective way to keep disturbances at a sustainable level. Axle box of a bogie has been equipped by two Piezo-accelerometers measuring the vertical and the lateral accelerations on both sides. The vertical accelerometers mainly sense corrugation, while the lateral ones can inform about the eventual lateral discontinuity, such as curve rail wear, or the presence of localised lateral defects and damaged switches. This leads to the suggestion that only the first wheel-set is responsible for corrugation growth. This fact is essentially paid in terms of number of collected data which is huge, therefore creating files that are hard to manage and which consume a lot of PC memory. That is why some different data analysis techniques have been developed, together with the measurement set-up, to make the system more effective and easy to handle: the final idea would be having some synthesis data, also available to the operator in almost real-time conditions, and easily stored, to have the track behaviour trend in subsequent checks.

In paper [7], a method for the identification of lateral and vertical track irregularity from acceleration measurements on board of the train is presented. And the effectiveness of the system is demonstrated by simulation results. Simulation using multi-body dynamics code, SIMPACK, to obtain acceleration data of bogies and car-body is demonstrated. The whole vehicle is built as the prototype of a subway train, which contains car-body, front and rear bogie frame, primary and secondary suspension, wheelsets and track. The American fifth grade spectrum is used to simulate the track irregularities, with the vehicle raveling on track with irregularities of vertical and lateral direction respectively. The simulation time is set to 45 seconds, with simulation step size 0.002 seconds, simulation speed 80 km/hr, straight track. Then the acceleration data of bogies and car body can be obtained, which is used in the time and frequency domain analysis of simulation results. The system reveals the fact that the vertical irregularities have the most significant effect on the bogie vertical vibration, with the coherent value related to a high degree. The track lateral irregularities have significant effect on bogie lateral vibration, as well as the track irregularity to car-body

vertical vibration, while the car-body lateral vibration is not closely related to the track lateral irregularity.

This paper [6] describes the use of sensors mounted on the bogie of an in-service vehicle to estimate the mean track alignment. According to this principle, either bogie lateral acceleration or yaw rate can be processed to give an estimate of mean lateral track irregularity, but a yaw rate gyro provides consistent estimates down to lower vehicle speeds than does an accelerometer and does not require compensation for the effects of bogie roll. An improved estimate can be obtained by inverting the dynamic relationship between the mean track alignment and the bogie yaw motion. The use of discrete accelerometers and gyroscopes fitted to a bogie, but without optical or contact sensors, is examined here. A bogie-mounted, yaw rate gyro, formerly used only to determine long wavelength curvature, is identified as an alternative to a laterally sensing accelerometer. In fact, a yaw rate gyro has advantages over a laterally sensing accelerometer. The relationship between the horizontal track alignment and the motions of parts of a railway vehicle is complicated by the ability of wheelsets to move laterally with respect to the track. The combined wheel and rail profiles cause a difference in the left and right wheel rolling radii when a wheelsets is shifted laterally with respect to the track.

The system in [8] uses IR sensors to detect the arrival and departure of trains at the railway level crossing and also it controls the opening/closing of the gates. The system uses two IR sensors to detect the arrival of the train and departure of the train. When the arrival of the train is sensed, signals are provided to the traffic indicating the arrival of the train on the track and the signal turns red and the motor operates to close the gate. The gate remains closed until the train completely moves away from the level cross. When the departure of the train is detected by another sensor, the traffic signal turns green and the motor operates to open the gate. Thus automation of the gate operations at the railway level cross is achieved using sensors. IR detects the arrival of a train. The servo motor is programmed to operate with the specified speed.

The method explained in [3] detects the presence of obstacles like rock, timber in the track using Bayesian analysis technique. Here a locomotive was used along the track and the signal generated by obstacle drop was filtered out from extremely high level of acoustic noise generated by locomotive motion using a novel Monte Carlo-based Bayesian analysis.

3. PROPOSED SYSTEM

The proposed system is able to find faults like crack, twist in the track during in-service with the

help of ultrasonic sensors. If fault is detected in the track, it will be intimated to the responsible person through Wi-Fi module. Using MEMS sensor we can identify a shaking of vehicle during a travelling through the cracked position in a track. Wi-Fi module will be connected to the arm7 controller using before that module should be configured with a defined baud rate and get a particular IP address, then the Wi-Fi module connected to ARM controller and railway track status will updated through that IP address.

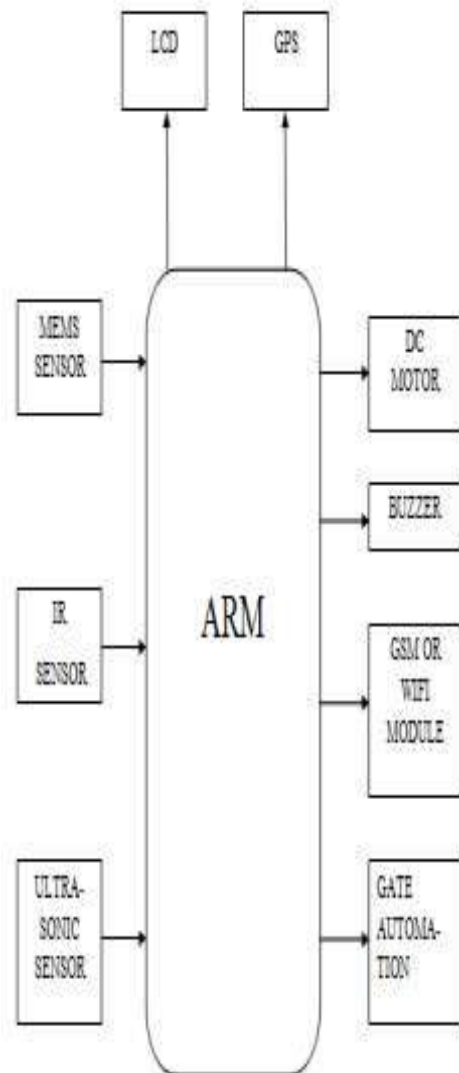

Fig.2 Architecture diagram of Railway Track Monitoring and Reporting

The proposed method also finds obstacle in the track using ultrasonic sensor in order to prevent from derailment. If an obstacle is found, it is intimated and the train will be stopped with an alarming sound. Additionally, this system also automates the gate operation at the level crossing. By this automation

traffic jam and accidents can be avoided and therefore it avoids human intervention, human hurdles.

4. CONCLUSION

The proposed system aims at reducing the human hurdles of operation to obtain accuracy and thereby it reduces cost and time required for the operation. It also ensures the safety of the passengers by increasing the frequency of checking.

5. REFERENCES

- [1] Boccione .M, Caprioli .A, Cigada .A , Collina, A measurement system for quick rail inspection and effective track maintenance strategy, *Mech. Syst. Signal Process.* 21 (2007) 1242–1254
- [2] Bruni .S , Goodall .R, Mei .T.X, Tsunashima .H, Control and monitoring for railway vehicle dynamics, *Veh. Syst. Dynam.* 45 (7–8) (2007) 765–771
- [3] Dhiraj sinha, Farhan Feroz, Obstacle Detection on Railway Tracks Using Vibration Sensors and Signal Filtering Using Bayesian Analysis, *IEEE sensors journal*, vol 16, 642-649, 2016
- [4] Goodall .R, Roberts .C, Concepts and techniques for railway condition monitoring, in: *IET International Conference on Railway Condition Monitoring*, 2006, pp. 90–95
- [5] Goodall .R, Mei .T, Advanced control and monitoring for railway vehicle suspensions, in: *International Symposium on Speed-up and Service Technology for Railway and Maglev Systems (STECH'06)*, Chengdu, China, 2006, pp. 10–16
- [6] Waston .P .F, Ling, Roberts, Goodman.C .J , Monitoring lateral track irregularity from in-service railway vehicles, *Proc. Inst. Mech. Eng. Part F: J. Rail Rapid Transit* 221 (2007) 89–100
- [7] Wei.X, Guo.S, Track irregularities estimation based acceleration in: *2012 International conference on Measurements, Information and Control*, Harbin, China, 2012, pp. 83-87
- [8] Wei .X , Guo .S, Liu .H , Sensor based automatic control of railway gates, in: *International Conference on Automatic Control and Artificial Intelligence (ACAI 2012)*, Xiamen, China, 2012, pp. 999–1004
- [9] Xiukun Wei, Feng Liu, Limin Jia, Urban rail track condition monitoring based on in-service vehicle acceleration measurements, *Measurements* 80(2016), pp.217-22