

Advanced Data Encoding Technique for Reducing Power Consumption in NOC

S.Kavitha

PG student, Dept. of E.C.E., Sree Sakthi Engineering college, Karamadai , Coimbatore, India

ABSTRACT:

The power dissipated by the links of Network-On-Chip (NOC) is very high when compared to other elements of communication system namely routers , and the network interfaces NI's . Aim of this paper is to reduce power consumption in the links. In this paper three sets of encoding schemes are discussed. In proposed method gray code input is given and power reduction analysis is done. when compared to binary code input gray code input consumes less power because the advantage of gray code is only one bit changes at a time.

KEYWORDS:

Binary to gray conversion, Data encoding, Interconnection on chip, Low power, Network-on-chip (NOC), Power analysis, Gray to binary conversion.

I. INTRODUCTION

In accordance with Moore's law density of transistors doubles every 18 months and currently we all know that there are millions of FETs on a single chip is known as VLSI. Integrating these FETs combine together to perform set of operations and applications such as DSP, Communications, Robotics and medical filed. Network on chip is a communication subsystem an on integrated circuit typical between IP cores in a system on a chip (SOC). NOC Technology applied methods to on chip communication and brings notable improvement over conventional bus and crossbar interconnections. NOC improves the scalability of SOC's and the power efficiency of complex SOC's compared to other designs. A network on chip uses packets to transfer data between IP core interfaces within a chip. The NOC based system on chips imposes various design issues on the fabrication of such integrated chips. Firstly, the suitable topology for the target NOCs such that the presentation supplies and design constraints are satisfied. Secondly, the design of

network interfaces to access the on chip network and routers provide the physical interconnection mechanisms to transport data between processing cores. Finally, as technology scales and switching speed increases, future network on chips will become more responsive and prone to errors and faults.

On-chip communication problems are more relevant to compare to the computational relevant problems. The computational subsystem has major objectives like including cost, performance, power dissipation, energy consumption, reliability thus, the total power of a system on chip depends on the communication subsystem.

In this work, we are going to reducing the power dissipation in the network links. The power dissipation in the network on chip is relevant to the power dissipation in the routers and Network Interfaces(NIs). For highly integrated electronic systems, the reduction of on-chip power dissipation is a essential one. The amount of power consumption in a NOC grows linearly by increasing the amount of bit transitions in consequent data packets sent through the interconnect architecture. By using the coding schemes we are reducing the switching activity on both wires and logic in this way we are reducing the power consumption in the NOC. The power due to self-switching activity of individual bus lines while ignoring the power dissipation owing to their coupling switching activity [2]. Data encoding is mainly used for reducing the number of bit transition over interconnects. Bus invert (BI), Adaptive coding, Gray coding and Transition method these are the various encoding techniques used in the NOC. We are using the data encoding with gray input is mainly reducing the power dissipation on the NOC.

This paper is organized as follows. We briefly discuss Previous Work in Section II, while Section III discuss an overview of the proposed encoding technique. The advanced data encoding schemes along with possible hardware implementations and their analysis are described in Section IV. The results for the hardware overhead, power and energy savings and performance of the proposed encoding schemes these are discuss in

Section V.

II. RELATED WORK AND MOTIVATION

The accessibility of chips are growing every years. In the next several years, the availability of cores with 1000 cores is foreseen[3]. Since the focus of this paper is on reducing the power dissipated by the links, here we briefly review some of the works in the area and link power reduction. Also these include some technique. There are, use of shielding [4], [5], increasing line-to-line spacing [6], [7], and repeater insertion [8]. Thus the above all the techniques having large area overhead. Another one method is the data encoding technique it mainly focus on reducing the link power reduction. The data encoding technique is classified into two categories. In the first category is mainly concentrate on minimizing the power due to self-switching activity of each bus lines and avoid the power dissipation due to coupling switching activity. In this category, bus invert [BI] [9] and INC-XOR [10] have been proposed. When the random patterns are transmitted via these lines. On the other hand, gray code [11], T0 [12], working-zone encoding [13], and T0-XOR [14] have been proposed for the case of correlated data patterns.

In this first category of encoding is not suitable for applied in deep sub-micron meter technology nodes where the coupling capacitance is a main part of the total interconnects capacitance. This causes the power due to the coupling switching activity to become a large portion of the link power reduction. In the second category concentrate on reducing power dissipated through the reduction of the coupling switching [7], [14]-[15]. The technique proposed in [16], proposed a method on power effective Bus Invert. In [15] they presented a method based on Odd/Even Bus-Invert techniques. If the number of switching transitions is half of the line width means the odd inversion is performed. In [9], the number of transitions from 0 to 1 for two data packets is counted. The number of 1's in the data packet is larger than the half of the links means the inversion will be performed and the number of 1's is reduced to 0 transitions when the packets are transfer through the links. In [17], the technique is used to reducing the coupling switching. From this method, the encoder counts the Type I transitions with the weighting coefficient of one and the Type II transitions with the weighting coefficient of two. If the number of 1's is larger than half of the links means the inversion will be performed and it

reducing the power consumption on the links. The technique proposed in [1] using the data encoding technique. This technique illustrate if the bits are encoded before they are injected into the network with the goal of minimizing the self-switching and the coupling switching in the links. These two are the main reason for the link power dissipation. Here they are classified the encoding technique into three scheme based on the four Types. In scheme 1 using the odd inversion and scheme 2 using the both odd inversion and full inversion and scheme 3 using the both odd, full and even inversion. Based on the odd, full and even inversion the power dissipation is reduced on the Network on chip (NOC) links. In this paper we present gray encoding technique, which focused on reducing the errors during the transition from transmitter to receiver and reducing the power dissipation in the links.

III. OVERVIEW OF THE PROPOSAL

The basic idea of the proposed technique is the packets are transferred through the network after that the bits are encoded. This technique is more helping to reduce the switching activity and coupling switching activity in the links traversed by the packets. This self-switching activity and coupling switching activity are responsible for the link power dissipation. Here we refer to end-to-end scheme. Based on the end to end scheme we are having a better advantage. The advantage is a pipeline nature of the wormhole switching technique [18]. Since the same sequence of all the packets passes through all the links of the routing path. The NI may provide the same power saving for all the links. The advanced scheme, an encoder and decoder block are added to the NI. The gray input is applied for all the three scheme encoders. The gray coding technique is used for the error correction application. The encoder encodes all the leaving bits of the packets other than header bit such that the power dissipated by the inter router and point-to-point link is minimized [19].

IV. PROPOSED ENCODING SCHEMES

The main goal of the proposed encoding scheme is to reduce the power dissipation by minimizing the coupling transition activities on the links of the interconnection network. In [17], they are classified four types of coupling transitions. A Type I occurs when one of the line is switches and remaining one is unchanged. A Type II occurs when one of the lines switches from low to high and another one is switches from high to low. A Type III occurs both the lines switches simultaneously. A Type IV occurs when both the lines are remains unchanged. The coupling switching activity (T_c) is defined as a weighted sum of different types of coupling transition

contribution [17]. Therefore,

$$T_c = K_1T_1 + K_2T_2 + K_3T_3 + K_4T_4 \text{ eq. (1)}$$

Where T_i is the average number of Type I transition and K_i is the corresponding weight.

A. Gray code:

The gray code is also known as reflected binary code. It is a binary numeral system, where two successive values differ in only one bit. The reflected binary code was originally designed to prevent false output from electromagnetic switches. It is mainly used for error correction application in digital communications.

B. Problem with binary code:

The problem with binary codes is that, with real switches. The switches will change states exactly in synchronously. In binary code, the two successive values differ in one or more bits. If the output pass through a sequential system then the sequential system may store a false value. The gray code solves the above problem by changing only one bit at a time.

Decimal	Binary Code (input)	Gray Code (output)
0	0000	0000
1	0001	0001
2	0010	0011
3	0011	0010
4	0100	0110
5	0101	0111
6	0110	0101
7	0111	0100
8	1000	1100
9	1001	1101
10	1010	1111
11	1011	1110
12	1100	1010
13	1101	1011
14	1110	1001
15	1111	1000

Table 1: Binary to Gray converter

C. Scheme I:

In scheme 1, our main goal is to reducing the number of Type 1 transitions and Type 2 transitions. Type 1 transitions is converted into Type III and Type IV transitions and Type II transitions is converted into Type I transitions. This scheme compares the two data's based on to reducing the link power reduction by doing odd inversion or no inversion operation.

Time	Normal			Odd inverted			Even inverted		
	Type I			Type II, III, IV			Type II, III, and IV		
t-1	00,11	00,11,01,10	01,10	00,11	00,11,01,10	01,10	01,10	00,11,01,10	00,11
t	10,01	01,10,00,11	11,00	10,01	00,11,01,10	10,01	10,01	00,11,01,10	11,00
	T1'	T1''	T1'''	Type III	Type IV	Type II	Type II	Type IV	Type III
t-1	Type II			Type I			Type I		
t	01,10			01,10			01,10		
t-1	00,11			11,00			00,11		
t	11,00						01,10		
t-1	Type II			Type II			Type II		
t	00,11,01,10			00,11,01,10			00,11,01,10		
t	00,11,01,10			01,10,00,11			10,01,11,00		

Table 2: Effect of Odd and Even inversion on change of Transition Types

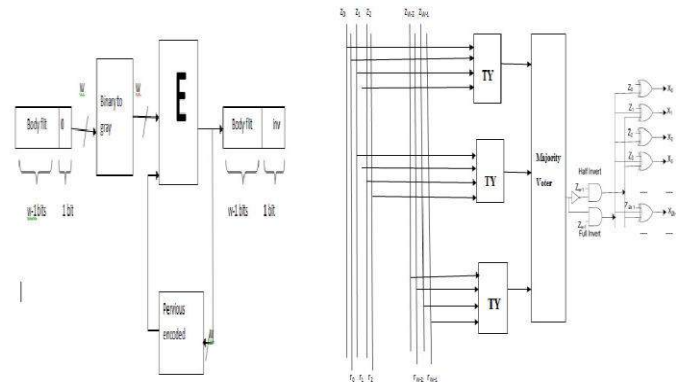

Fig. 1. Scheme 1.(a) Block diagram. (b) Architecture for encoder block

$$T_y > T_x \dots \dots \dots \text{eq(2)}$$

$$T_y > 0.5 (w-1) \dots \dots \dots \text{eq(3)}$$

The general block diagram in Fig. 1(a) is same for scheme 1, scheme 2 and scheme 3. The w-1 bit is given to the one input of the binary to gray conversion block. This block converts the original binary input into gray output. The output of the gray code is given as input of encoder block and another input of the encoder block is the previously encoded output. The encoder block compares these two inputs and performing the any one of the inversion based on the transition types. The block E is vary for all the three schemes. Comparing the current data and previous encoded data to decide which inversion is performed for link power reduction. Here the TY block this takes two adjacent bits from the given inputs. From these two input bits the TY block checks what type of transitions occurs, whether more number of type 1 and type 2 transitions is occurring means it set the output state to 1, otherwise it set the output to 0. The odd inversion is performed for these type of transitions. Then the next block is the Majority code it checks the state, if the number of one's is greater than zeros or not and it implemented using a simple circuit. The last stage using the XOR circuits, these circuit is used to perform the inversion on odd bits. The decoding is performed by simply inverts the encoder circuit when the inverting bit is high.

D. Scheme II:

In scheme II, our main goal is to reducing the number of Type II transitions. Type II transitions are converted into Type IV transitions. This scheme compares the two data's based on to reducing the link power reduction by doing full inversion or odd

inversion or no inversion operation.

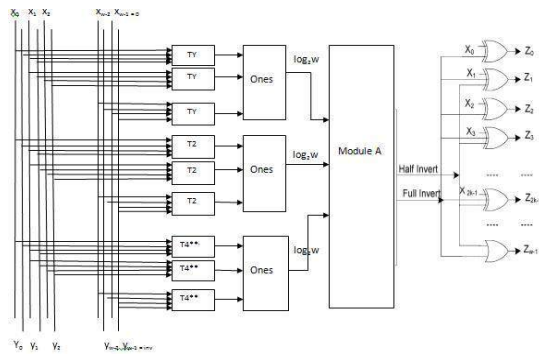

Fig.2. Encoder architecture scheme II

$$T_2 > T_4^{**} \dots \dots \dots \text{Eq}(4)$$

Full and odd inversion based this advanced encoding architecture consist of w-1 link width and one bit for inversion bit which indicate if the bit travel through the link is inverted or not. W bits link width is considered when there is no encoding is applied for the input bits. Here the TY block from scheme 1 is added in scheme 2. This takes two adjacent bits from the given inputs. From these two input bits the TY block checks what type of transitions occurs. We have T2 and T4** blocks which determines if any of the transition types T2 and T4** occur based on the link power reduction. The number of ones blocks in the next stage. The output of the TY, T2 and T4** send through the number of one's blocks. The output of the ones block is log₂ w. The first ones block is used to determine the number of transitions based on odd inversion. The second ones block determines the number of transitions based on the full inversion and the then another one ones block is used to determine the number of transitions based on the full inversion. These inversions are performed based on the link power reduction. Based on these ones block the Module A takes the decision of which inversion should be performed for the link power reduction. For this module is satisfied means the output is set to '1'. None of the output is set to '1' if there is no inversion is takes place. The module A is implemented using full adder and comparator circuit.

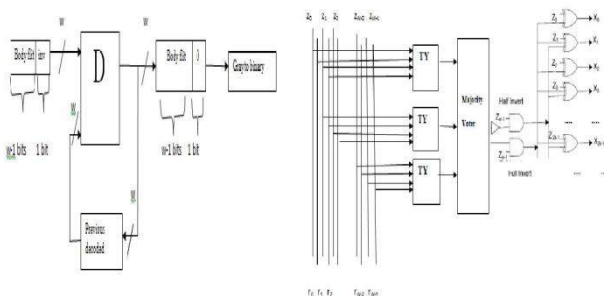

Fig.3. Block diagram for decoder

Fig.4. Decoder architecture scheme II

The block diagram of the decoder is shown in Fig.3. The w-1 bits input is applied in the decoder circuit and another input of the decoder is previous decoded output. The decoder block compares the two input data's and inversion operation is performed and w-1 bits output is produced. The remaining one bit is used to indicate the inversion is performed or not. Then the decoder output is given to the gray to binary block. This block converts the gray code into original binary input.

In decoder circuit diagram (Fig.4.) consist of TY block and Majority vector and Xor circuits. Based on the encoder action the TY block is determined the transitions. Based on the transitions types the majority blocks checks the validity of the inequality given by(2). The output of the majority voter is given to the Xor circuit. Half inversion, full inversion and no inversion is performed based on the logic gates.

E. Scheme III:

In scheme III, we are adding the even inversion into scheme II. Because the odd inversion converts Type I transitions into Type II transitions. From table II, T1 / T1** are converted into Type IV/Type III transitions by the flits is even inverted. The link power reduction in even inversion is larger than the Odd inversion.

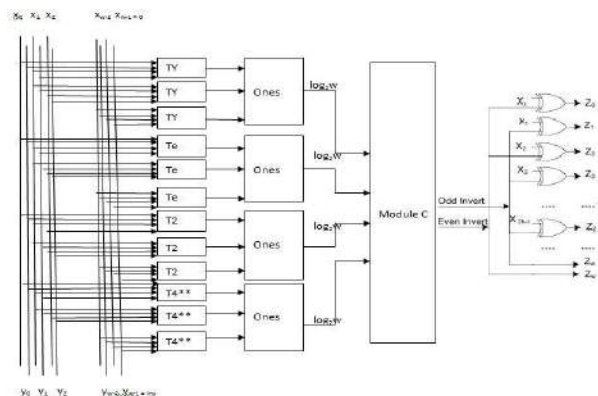

Fig.5. Encoder architecture for scheme III

The encoding architecture (Fig.5) in scheme III is same of encoder architecture in scheme I and II. Here we adding the Te block to the scheme II. This is based on even invert condition, Full invert condition and Odd invert condition. It consist of w-1 link width input and the w bit is used for the inversion bit. The full, half and even Inversion is performed means the inversion bit is set '1', otherwise it set as '0'. The TY, Te and T4** block determines the transition types T2, Te and T4**. The transition types are send to the number of ones block. The Te block is determined if any of the detected

transition of types T_2 , T_1^{**} and T_1^{**} . The ones block determines the number of ones in the corresponding transmissions of T_Y , T_2 , T_e and T_4^{**} . These number of ones is given to the Module C block. This block check if odd, even, full or no invert action corresponding to the outputs $_{10}^c$, $_{01}^c$, $_{11}^c$ or $_{00}^c$ respectively, should be performed. The decoder architecture of scheme II and scheme III are same.

V. RESULTS AND DISCUSSION

Figure 6 shows power calculated for scheme 1 with gray code input. In scheme 1 odd inversion and no inversion is performed.

	Voltage [V]	Current [m]	Power [m]
Vccint	1.2		
Dynamic		0.92	1.11
Quiescent		35.00	42.00
Vccaux	2.5		
Dynamic		0.00	0.00
Quiescent		20.00	50.00
Vcco25	2.5		
Dynamic		9.50	23.75
Quiescent		0.00	0.00
Total Pow			116.86

Figure 6 power for scheme1 with gray code input

Figure 7 shows power calculated for scheme 2 with gray code input. Here odd inversion , no inversion , full inversion is performed.

	Voltage [V]	Current [m]	Power [m]
Vccint	1.2		
Dynamic		1.26	1.52
Quiescent		35.00	42.00
Vccaux	2.5		
Dynamic		0.00	0.00
Quiescent		20.00	50.00
Vcco25	2.5		
Dynamic		0.00	0.00
Quiescent		0.00	0.00
Total Pow			93.52

Figure 7 power for scheme 2 with gray code input

Figure 8 shows power calculated for scheme 3 with gray code input. here odd inversion , even inversion, full inversion , no inversion is done.

	Voltage [V]	Current [m]	Power [m]
Vccint	1.2		
Dynamic		1.44	1.73
Quiescent		35.00	42.00
Vccaux	2.5		
Dynamic		0.00	0.00
Quiescent		20.00	50.00
Vcco25	2.5		
Dynamic		0.00	0.00
Quiescent		0.00	0.00
Total Pow			93.73

Figure 8 power for scheme 3 with gray code input

VI. CONCLUSION AND FUTURE WORK

In this work, the gray encoding technique is implemented for reducing the transition activity in the NOC. This gray encoding scheme aimed at reducing the power dissipated by the links of an NOC. In fact links are responsible for a significant fraction of the overall power dissipated by the communication system. The proposed encoding schemes are agnostic with respect to the underlying NOC architecture in the sense that our application does not require any modification neither in the links nor in the links. The proposed architecture is coded using VERILOG language and its power is calculated using xilinx software. Output is simulated and synthesized using Modelsim software.

In the future, the Network On Chip (NOC) implementation using different types of router technique will be analyzed . Comparison on many encoding techniques such as gray encoding techniques will be analyzed in which the area, delay, power and the performance of the NOC will be investigated and use for high speed applications.

REFERENCES

1. Nima Jafarzadeh, Maurizio Palesi, Ahmad , and Afzali-Kusha, —Data Encoding Techniques for Reducing Energy Consumption in Network-on-Chip| IEEE Trans. Very Large ScaleIntegr. (VLSI) Syst,Mar.2014.
2. International Technology Roadmap for Semiconductors. (2011) [Online].Available: <http://www.itrs.net>
3. D. Yeh, L. S. Peh, S. Borkar, J. Darringer, A. Agarwal, andW. M. Hwu, —Thousand-core chips roundtable,| *IEEE Design Test Comput.*, vol. 25, no. 3, pp. 272–278, May–Jun. 2008.
4. D. Yeh, L. S. Peh, S. Borkar, J. Darringer, A. Agarwal, andW. M. Hwu, —Thousand-core

- chips roundtable, *IEEE Design Test Comput.*, vol. 25, no. 3, pp. 272–278, May–Jun. 2008.
5. M. Ghoneima, Y. I. Ismail, M. M. Khellah, J. W. Tschanz, and V. De, —Formal derivation of optimal active shielding for low-power on-chip buses, *IEEE Trans. Comput.-Aided Design Integr. Circuits Syst.*, vol. 25, no. 5, pp. 821–836, May 2006.
 6. L. Macchiarulo, E. Macii, and M. Poncino, —Wire placement for crosstalk energy minimization in address buses, *Proc. Design Autom. Test Eur. Conf. Exhibit.*, Mar. 2002, pp. 158–162.
 7. R. Ayoub and A. Orailoglu, —A unified transformational approach for reductions in fault vulnerability, power, and crosstalk noise and delay on processor buses, *Proc. Design Autom. Conf. Asia South Pacific*, vol. 2, Jan. 2005, pp. 729–734.
 8. K. Banerjee and A. Mehrotra, —A power-optimal repeater insertion methodology for global interconnects in nanometer designs, *IEEE Trans. Electron Devices*, vol. 49, no. 11, pp. 2001–2007, Nov. 2002.
 9. M. R. Stan and W. P. Burleson, —Bus-invert coding for low-power I/O, *IEEE Trans. Very Large Scale Integr. (VLSI) Syst.*, vol. 3, no. 1, pp. 49–58, Mar. 1995.
 10. S. Ramprasad, N. R. Shanbhag, and I. N. Hajj, —A coding framework for low-power address and data busses, *IEEE Trans. Very Large Scale Integr. (VLSI) Syst.*, vol. 7, no. 2, pp. 212–221, Jun. 1999.
 11. C. L. Su, C. Y. Tsui, and A. M. Despain, —Saving power in the control path of embedded processors, *IEEE Design Test Comput.*, vol. 11, no. 4, pp. 24–31, Oct.–Dec. 1994.
 12. L. Benini, G. De Micheli, E. Macii, D. Sciuto, and C. Silvano, —Asymptotic zero-transition activity encoding for address busses in low-power microprocessor-based systems, *Proc. 7th Great Lakes Symp. VLSI*, Mar. 1997, pp. 77–82.
 13. E. Musoll, T. Lang, and J. Cortadella, —Working-zone encoding for reducing the energy in microprocessor address buses, *IEEE Trans. Very Large Scale Integr. (VLSI) Syst.*, vol. 6, no. 4, pp. 568–572, Dec. 1998.
 14. S. Youngsoo, C. Soo-Ik, and C. Kiyoun, —Partial bus-invert coding for power optimization of application-specific systems, *IEEE Trans. Very Large Scale Integr. (VLSI) Syst.*, vol. 9, no. 2, pp. 377–383, Apr. 2001.
 15. Z. Yan, J. Lach, K. Skadron, and M. R. Stan, —Odd/even bus invert with two-phase transfer for buses with , *Proc. Int. Symp. LowPower Electron. Design*, 2002, pp. 80–83.
 16. Z. Yan, J. Lach, K. Skadron, and M. R. Stan, —Odd/even bus invert with two-phase transfer for buses with , *Proc. Int. Symp. LowPower Electron. Design*, 2002, pp. 80–83.
 17. K. W. Ki, B. Kwang Hyun, N. Shanbhag, C. L. Liu, and K. M. Sung, —Coupling-driven signal encoding scheme for low-power interface design, *Proc. IEEE/ACM Int. Conf. Comput.-Aided Design*, Nov. 2000, pp. 318–321.
 18. M. Palesi, G. Ascia, F. Fazzino, and V. Catania, —Data encoding schemes in networks on chip, *IEEE Trans. Comput.-Aided Design Integr. Circuits Syst.*, vol. 30, no. 5, pp. 774–786, May 2011.
 19. M. Palesi, G. Ascia, F. Fazzino, and V. Catania, —Data encoding schemes in networks on chip, *IEEE Trans. Comput.-Aided Design Integr. Circuits Syst.*, vol. 30, no. 5, pp. 774–786, May 2011.

BIOGRAPHY

S.Kavitha is a PG Scholar in Sree Sakthi Engineering College , Karamadai, India. She received her U.G Course in Sasurie college of engineering India. Her area of interest is Networking and Embedded System.