

# Effect of Pulse Shape Modulation with Maximal Ratio Combiner Scheme on the Performance of 802.15.3a UWB Channel Model

Author: Sachin Taran<sup>1</sup>; Dhiraj Nitnaware<sup>2</sup>

Affiliation: Electronics and Communication, MGI, Indore<sup>1</sup>; Electronics and Communication, IET DAVV, Indore<sup>12</sup>

E-mail: taran.sachin@gmail.com<sup>1</sup>; Dhirajnitnawwre@gmail.com<sup>2</sup>

## ABSTRACT

In this paper we proposed an analytical method which is used for 802.15.3a UWB channel to find out the effect of pulse shape modulation (PSM) with Maximal ratio combining (MRC) scheme. We used a mathematical model of instantaneous SNR which is derived while considering the receiver is MRC rake receiver. For the performance evaluation the parameter which is selected is average bit error rate (ABER). In the ABER calculation conditional BER for pulse shape modulation (PSM) is integrated with the probability density function (PDF) of instantaneous SNR. The PDF for instantaneous SNR is calculated using Wilkinson's method. So finally we developed a performance check with pulse shape modulation (PSM) for UWB indoor channel and it will be better choice for UWB as its short distance applications.

**Keywords:** 802.15.3a UWB channel model, Lognormal fading, Wilkinson's method, Maximal ratio combiner (MRC), Pulse shape modulation (PSM).

## 1. INTRODUCTION

A widely accepted UWB (Ultra Wide Band) indoor communication channel model 802.15.3a developed by channel modeling subcommittee and it is define in [1, 2].

### 1.1 Signal and Channel Model

According to [2] the 802.15.3a channel model UWB system exhibits high frequency selective

fading and can be modeled as a discrete linear filter whose impulse response is expressed as,

$$h(t) = \sum_{l=0}^{L_{\max}-1} \beta_l \alpha_l \delta(t - \tau_l) \quad (1)$$

The  $L_{\max}$  is the maximum number of resolvable multipath components (MPCs) and it is decided by the number of fingers of rake receiver or sampling resolution of receiver.

The  $\alpha_l$  is the channel fading coefficient for the  $l^{\text{th}}$  path and its modeled as lognormal random variable, whose parameter depends on the arrival time  $\tau_l$ . The  $\tau_l$  is arrival time of  $l^{\text{th}}$  path relative to 1<sup>st</sup> path ( $l=0$  &  $\tau_0 = 0$  assumed) and  $\delta(t)$  is Dirac delta function.

The channel gain  $\alpha_l$  is modeled as  $\alpha_l = p_l \beta_l$ , where  $p_l = +1 / -1$  with equal probability it models the random pulse inversion that can occur due to reflections it is define in [2]. The second term  $\beta_l$  is a magnitude of  $l^{\text{th}}$  MPC and it is log normally distributed for indoor channels. The parameters of lognormal random variable are mean and standard deviation. The standard deviation of fading amplitude is in the range of 3-5dB given in [2] and mean value depends on the parameters of channel profile CM1, CM2, CM3, CM4 such as cluster arrival rate, ray arrival rate, cluster decay factor, ray decay factor etc given by [1, 2].

These channel profile parameters such as distribution of path arrival time sequence  $\tau_l$  and power delay profile (PDP) of the channel are chosen to follow the modified Saleh-Valenzuela (S-V) model suggested in [3].

### 1.2 Pulse Shape Modulation (PSM)

Pulse shape modulation (PSM) uses different, orthogonal waveforms to represent bit '0' and '1'. The transmitted pulse can be represented as

$$X(t) = (1 - d_j) * W_{tr}^{(0)}(t) + d_j * W_{tr}^{(1)}(t)$$

Where  $d_j$  is defined as below and  $W_{tr}^{(0)}$  and  $W_{tr}^{(1)}$  represent two different waveforms

$$d_j = \begin{cases} -1, & j = 0 \\ 1, & j = 1 \end{cases}$$

Figure 1 shows an example pair of PSM pulses it is given in [4]. This case uses the first and the second derivatives of the Gaussian pulse. These two waveforms are orthogonal according to the definition given by the cross correlation of the two waveforms

$$\rho_c(t) \{ \text{at } t=0 \} = \int_{-\infty}^{+\infty} W_{tr}^{(0)}(\tau) W_{tr}^{(1)}(t - \tau) d\tau = 0$$

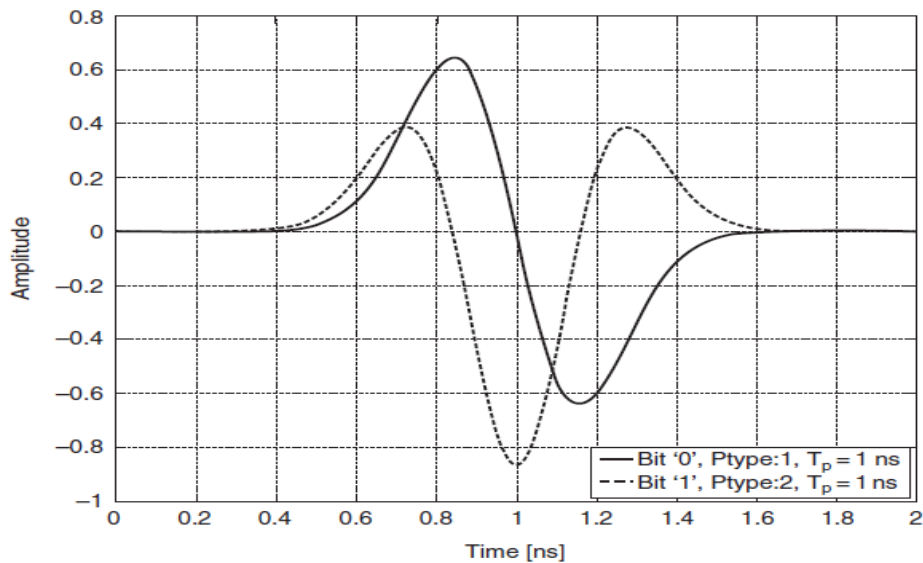

Figure 1. Examples of the pulse waveforms used for PSM modulation

### 1.3 Maximal ratio combining (MRC)

It is well known that a RAKE receiver with maximal ratio combining (MRC) is optimum when the desired signal is distorted by the additive white Gaussian noise (AWGN). Maximal-Ratio

Combining, first discussed by Brennan, is the optimal form of diversity combining because it yields the maximal SNR achievable. It requires the exact knowledge of SNRs as well as the phases of the diversity signals as [5].

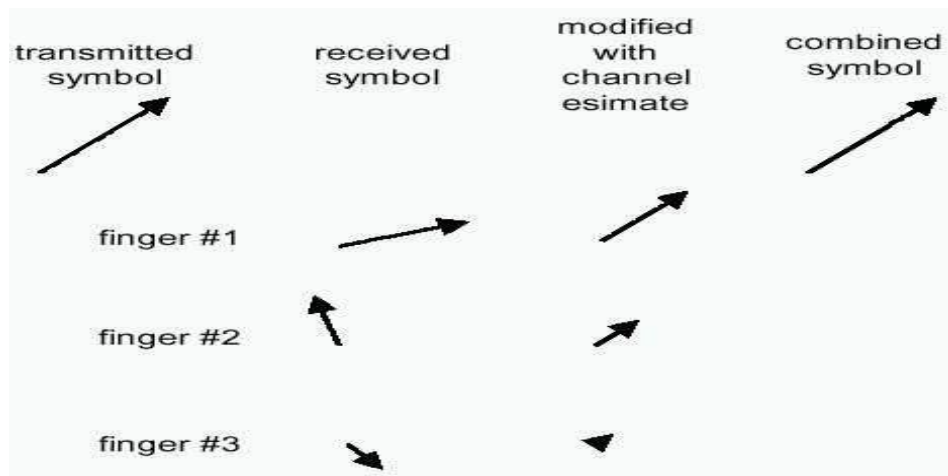

Figure 2. Maximal Ratio Combining in RAKE

After de-spreading the received symbol from transmitter via radio channel the symbols from allocated fingers are maximal-ratio-combined to construct the “combined” symbol. The output symbols from different fingers are multiplied with complex conjugate of the channel estimate and the result of multiplication is summed together into the

“combined” symbol. This is illustrated in Figure 2 and Figure 3 given in [6]. in this paper we have selected MRC scheme because it is performance similar to minimum mean square error (MMSE) combining scheme but complexity is lower than MMSE this is also proved in [7].

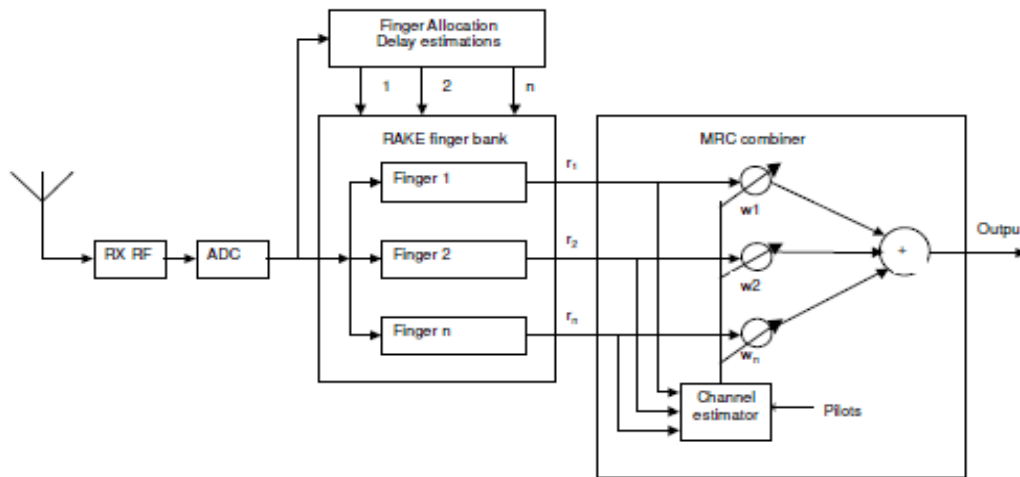

Figure 3. RAKE receiver using MRC

We ask that authors follow some simple guidelines. In essence, we ask you to make your paper look exactly like this document. The easiest way to do this is simply to download the template, and replace the content with your own material.

**2. PROBLEM FORMATION**

As in [8] they present the instantaneous signal to noise ratio (SNR) model by considering one of the channel impairments i.e. intra pulse interference (IPI) according to [8] for a realistic UWB system having a finite temporal resolution  $T_p$  i.e. often limited by the receiver sampling frequency or the width of UWB pulse. The instantaneous signal to noise ratio (SNR) per bit can be written as

$$\gamma_i = \frac{E_s}{N_0} \sum_{l=0}^{\lceil \frac{T_i}{T_p} \rceil - 1} \gamma_l^2$$

$$= \frac{E_s}{N_0} \sum_{l=0}^{\lceil \frac{T_i}{T_p} \rceil - 1} [\sum_{i \in I_l} (\beta_i \alpha_i)]^2 \tag{2}$$

From (2), the receiver seems to be a maximum ratio combining (MRC) Rake receiver with  $\lceil \frac{T_i}{T_p} \rceil$  uniformly-spaced fingers, where the effective

weighting coefficient of the  $l^{th}$  finger is  $\sum_{i \in I_l} (\beta_i \alpha_i)$ .

In this model second summation is taken for accounting the intra pulse interference i.e. occurs between MPCs. where  $I_l$  is set given by:  $I_l = \{ i \mid lT_p \leq \tau_i < (l + 1)T_p \}$  denotes the collection of multipath components (MPCs) arriving in the interval  $[lT_p, (l + 1)T_p]$ , i.e. the number of MPCs in a single finite temporal resolution but right now in this paper the impairments that we want to model is shadowing not the intra pulse interference so width of pulse is adjusted such that  $T_p \ll 1$ . In this case  $\gamma_l \rightarrow \beta_l \alpha_l$  and equation (2) from the [8] can be written as

$$\gamma_i = \frac{E_s}{N_0} \sum_{l=0}^{L_{max} - 1} \alpha_l^2 \tag{3}$$

**3. PERFORMANCE ANALYSIS**

The major parameters that researchers generally use to figure out the performance of UWB channel are outage probability and average bit error rate (ABER). In this paper we are using the ABER. The process of finding the ABER given in [9], the average bit error rate can be calculated by

averaging the conditional BER which is  $P(\gamma_i)$  over the probability density function (PDF) of instantaneous SNR i.e.  $f(\gamma_i)$  as

$$P_e = \int_0^{\infty} P(\gamma_i) f(\gamma_i) d\gamma_i \quad (4)$$

The conditional BER for fixed set of  $\beta_i$  for PSM orthogonal pulses shown in figure 1 is given as according to [10]

$$P(\gamma_i) = Q(\sqrt{\gamma_i}) = Q\left(\sqrt{\frac{E_b}{N_0}}\right) = Q(\sqrt{SNR})$$

The conditional BER is a function of SNR. For calculating the ABER we require the PDF of instantaneous SNR  $f(\gamma_i)$ . There are many methods for calculating the PDF of instantaneous SNR. A major section of research in the field of UWB has been done for finding the accurate PDF of their instantaneous SNR model. In [8] they have suggested three methods for approximating the PDF of instantaneous SNR model according to severances of fading. The distributions used in [8] to approximate the PDF of  $\gamma_i$  are coxian, Lognormal, Gamma and parameters of these approximation are find out using least square error criteria by minimizing the mean square error. Our process for finding the PDF of instantaneous SNR is little bit different and it is best according to our model. In this paper we have computed the PDF of

term  $\left(\frac{E_s}{N_0}\right) \sum_{l=0}^{L_{\max}} \alpha_l^2$ . This term is simply the square of sum of lognormal random variables and estimation of distributions can be given by [11]. They have suggested three methods for the estimation of distribution. The method which we are using in this paper is Wilkinson's method. From Wilkinson's method the PDF of instantaneous SNR given as

$$f(\gamma_i) = \frac{1}{\gamma_i \sqrt{2\pi\sigma_z^2}} \exp\left[-\frac{(\ln(\gamma_i) - \mu_z)^2}{2\sigma_z^2}\right]$$

Parameter of this PDF is mean ( $\mu_z$ ) and standard deviation ( $\sigma_z$ ) which comes from [11].

#### 4. NUMERICAL RESULT: FRAMEWORK VALIDATION

The result is obtained for different channel profile. The Number of rake receiver finger is  $L = 10$ . To obtain this result the range of SNR  $\left(\frac{E_s}{N_0}\right)$  is 1 to 10dB.

The channel model 1 is of a line of sight (LOS) case with the transmitter and the receiver antenna being separated by a distance in the range (0-4 m). The channel model 2 for a non line of sight (NLOS) case with antenna separation being in the range (0-4 m).

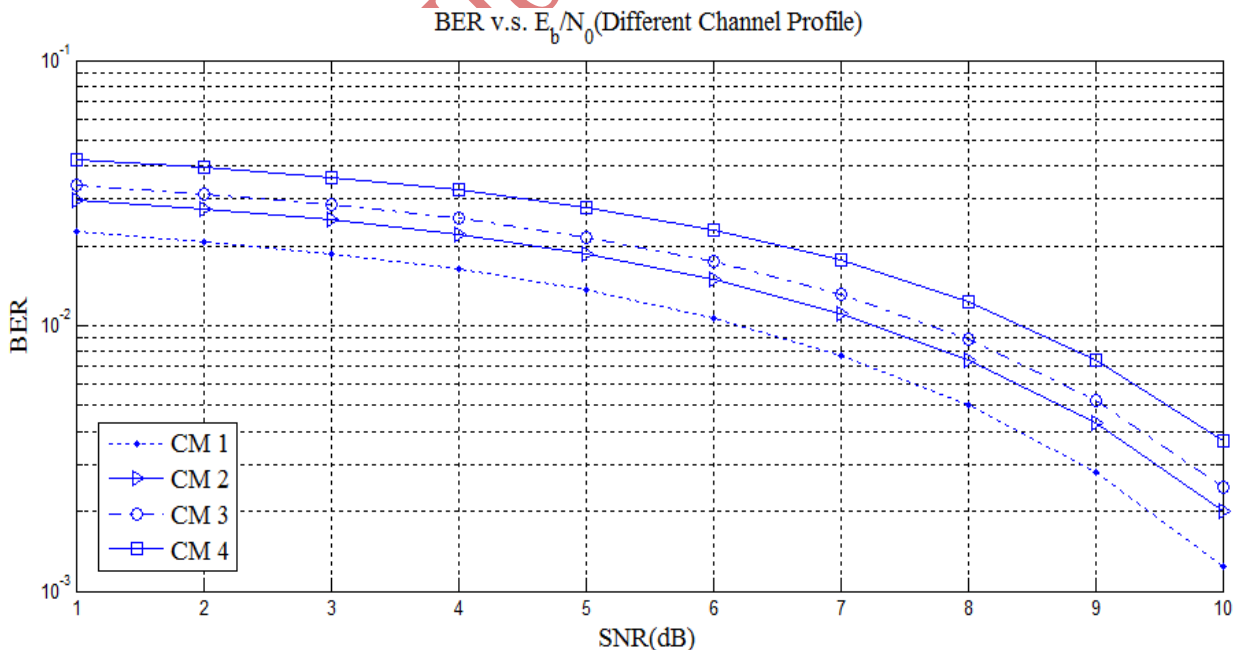

Figure 4. BER Performance of the IEEE 802.15.3a UWB channel for PSM with MRC for different channel profile

The channel model 3 for a non line of sight (NLOS) case with antenna separation being in the range (4-10 m). The channel model 4 for a extreme NLOS multipath channel to fit a 25 ns RMS delay spread. The parameters used for these different channel profiles are given in [2].

## 5. CONCLUSION

We proposed an analytical method which is too easy to verify the performance of 802.15.3a channel model for PSM with MRC receiver. In this analytical method for calculation of ABER we require PDF of instantaneous SNR which is estimated from the Wilkinson's method. Finally we got computable formula for ABER. We derived our results for different channel profile with PSM technique. The results clearly shows that PSM maintain the criterion of indoor UWB channel in which minimum ABER should come for channel model 1 (CM1) and maximum for channel model 4 (CM4) and we are getting expected result according to UWB channel committee. So PSM could also be good choice for UWB as a data mapping techniques. One interesting research topic that can be extended from this work is to apply this method to any multipath fading models with other general random arrival process for clusters and rays, such as the IEEE 802.15.4a outdoor channel model.

## 6. REFERENCES

- [1]. A. F. Molisch, J. R. Foerster, and M. Pendergrass "Channel models for ultrawideband personal area networks," IEEE Wireless Commun., vol. 10, pp. 14–21, Dec. 2003.
- [2]. J. Foerster, Ed., "Channel Modeling Sub- commi. Report Final," IEEE, Document IEEE P802.15-02/490r1-SG3a, 2003.
- [3]. A. A. M. Saleh and R. Valenzuela, "A statistical model for indoor multipath propagation," IEEE J. Select. Areas. Commun., vol. SAC-5, no. 2, pp. 128–137, Feb. 1987.
- [4]. Ian Oppermann, Matti Hamalainen and Jari Iinatti, UWB Theory and Applications, 1st ed. New John Wiley & Sons Ltd, 2004, ch. 4.
- [5]. Samuel C. Yang, CDMA RF System Engineering, Norwood MA, USA, Artech House Inc., 1998, 280 pp.
- [6]. Mikko Järvelä, RAKE training slides by Nokia, 03.04.2001, Oulu.
- [7]. Shiwei Zhao and Huaping Liu, Member, IEEE on the Optimum Linear Receiver for Impulse Radio Systems in the Presence of Pulse Overlapping IEEE communications letters, vol. 9, no. 4, April 2005.
- [8]. A.-R. Chadi, "Performance analysis of UWB systems over the IEEE802.15.3a channel model," IEEE Trans. Commun., Presence of Pulse Overlapping IEEE communications letters, vol. 9, no. 4, April 2005.
- [9]. John G. Proakis, Masoud Salehi, Digital Communications, 5th ed. New York: McGraw-Hill, 2008, ch. 14.
- [10]. Huseyin Arslan, Zhi Ning Chen, Maria-Gabriella Di Benedetto, Ultra wideband wireless communication, 3rd ed. New John Wiley & Sons Ltd, 2006, ch. 4.
- [11]. N. C. Beaulieu, A. A. Abu-Dayya, and P. J. McLane, "Estimating the distribution of a sum of independent lognormal random variable," IEEE Trans. Comm., vol. 43, pp. 2869–2873, Dec. 1995.