

# WSN Based Environment Monitoring With Solar Backup

Dhiraj Nitnaware

Electronics and Telecommunication Department  
Institute of Engineering and Technology, DAVV, Indore

*dhiirajnitnawwre@gmail.com*

## ABSTRACT

There is a rapid growth of wireless networking mainly focused on high-speed communications, and relatively long range applications such as the IEEE 802.11 Wireless Local Area Network (WLAN) standards and Low-Rate Wireless Personal Area Networks (LR-WPAN) such as Bluetooth. There are many wireless monitoring and control applications in industrial and home environments which require longer battery life, lower data rates and less complexity than those from existing standards. The goal of this paper is to develop fully functional wireless sensor platform with Zigbee and IEEE 802.15.4 modules using 32 bit Controller to support the wireless application for monitoring of environmental parameters with solar back up. The monitoring parameters are temperature, humidity and intensity of light. The two modules were checked with Battery and one Module with Solar Backup and their performance has been compared.

**Keywords:** WSN, Environmental parameter, Solar backup, Zigbee and IEEE 802.15.4.

## 1. INTRODUCTION

The past several years have witnessed a rapid growth of wireless networking. However, up to now wireless networking has been mainly focused on high-speed communications, and relatively long range applications such as the IEEE 802.11 Wireless Local Area Network (WLAN) standards. The first well known standard focusing on Low-Rate Wireless Personal Area Networks (LR-WPAN) was Bluetooth. However it has limited capacity for networking of many nodes. There are many wireless monitoring and control applications in industrial and home environments which require longer battery life, lower data rates and less complexity than those from existing standards. For such wireless applications, a new standard called IEEE 802.15.4 has been developed by IEEE. The new standard is also called ZigBee, when additional stack layers defined by the ZigBee Alliance are

used.

The paper is organized as: Section 2 discuss the problem domain while proposed solution is explained in section 3. Results and analysis is given in section 4 while conclusion is in section 5.

## 2. PROBLEM DOMAIN

The author of paper [1] have developed a wireless system for monitoring and diagnosis of environmental parameters in Industrial system while in paper [2], the authors have explained weighted centroid localization using Zigbee based sensor networks.

The authors of paper [3] also developed wireless industrial monitoring and control system using smart sensor platform. The problem in all previous work is that the system is developed which required DC battery for the operation. If battery gets discharged, the platform will not work.

## 3. PROPOSED SOLUTION

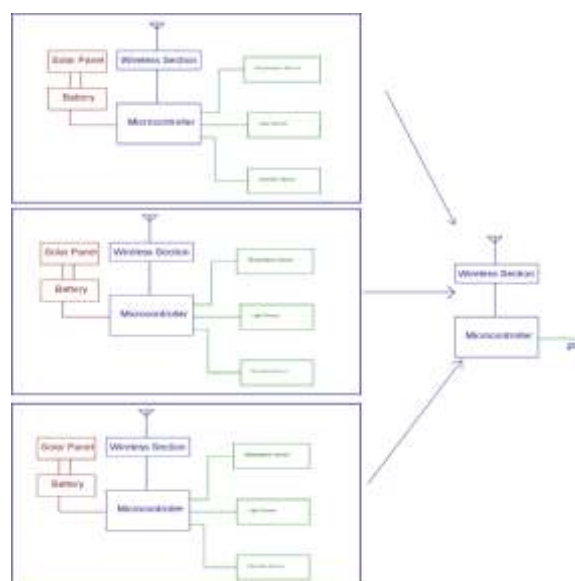

Figure 1: Block Diagram of Complete System

The solution is to use battery backup so that the system will work for longer duration of time. The solar backup is used for the same. The block diagram of complete system is shown in figure 1. The transmitter section of single node is given in figure 2. The power supply uses a Solar Panel & 5 AA Size Rechargeable Batteries for Back up. IC LM1117-3.3V is used to regulate power supply of +3.3V. Capacitors are used as filter. The Microcontroller is the heart of the Network Node. Temperature, Humidity & Light sensor are connected to the Port Pin of the controller. It also provides Wireless Connectivity via ZigBee.

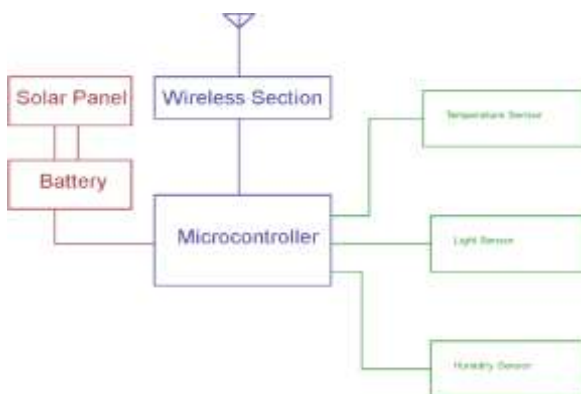

Figure 2: Block diagram of Single Sensor Node

SHT1x is Sensirion's family of surface mountable relative humidity and temperature sensors. The sensor integrate sensor elements plus signal processing on a tiny foot print and provide a fully calibrated digital output. A unique capacitive sensor element is used for measuring relative humidity while temperature is measured by a band-gap sensor. This gives 12 bit output for Humidity & 14 bit output for temperature.

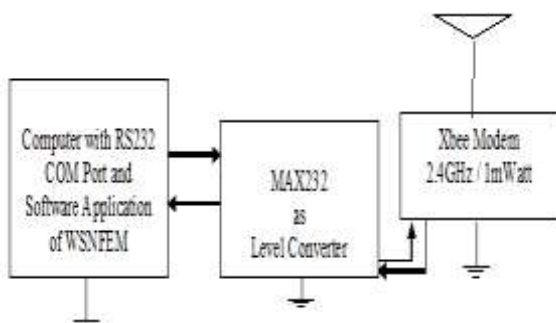

Figure 3: Block diagram of Device at Control Room

The wireless receiver is required at PC side for sending and receiving the signal to and from Sensor Node. The PC connectivity is through RS232 communication. The PC firmware is written in VB6.0. The connectivity is using

COM1 at 19200 Baud with 8, 1, 0 format. The wireless module is connected on connecting strips i.e. 20 pins interface. The connection through PC is by RX, TX, and Gnd. The interface between RS232 logic and +3.3V logic MAX232 is used. The module runs on 3.3V power supply. LM1117 3.3 is used as voltage regulator for +3.3V required for RF module.

#### 4. RESULTS AND ANALYSIS

The application software main window is given in figure 3. User has to select com port to which master station is connected, once the connection is established between PC and master unit it starts communicating with three different sensor nodes and receives the data and displays on the Software Window. The measured and monitored data is represented in three different ways on Software.



Figure 4: Application Software Main Window

The unit is working and the three different parameters Temperature, Humidity and Light Intensity is measured and monitored remotely on PC VIA Software developed. We have provided three different ways to display the results. Following figure shows how to connect the master receiver module with software.

#### 4.1 Reading Window



Figure 5: Reading Window

Here the data from three nodes are monitored on the software window developed in VB6.0. The parameters

such as temperature, humidity and light intensity is displayed in the reading window. Figure 5 shows the reading window.

### 4.2 Graph Window

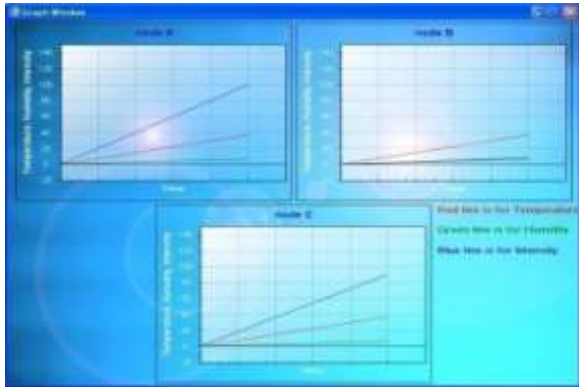

Figure 6: Graph Window

Here the data from three nodes are displayed in the form of graph shown in figure 6.

### 4.3 Reading Table Window



Figure 7: Reading Table Window

Here the real time data from three nodes are monitored in the form of table given in figure 7.

### 4.4 Analysis

We have connected one sensor module with normal battery and one sensor node with rechargeable battery using solar panel. The System Voltage and Current is measured at same time interval and found that the Solar Power Back-up works for longer duration of time compared to normal battery operated sensor module. Figure 8 gives the voltage and current reading without solar backup while figure 9 shows with solar backup.

| Time     | Voltage | Current | Time     | Voltage | Current |
|----------|---------|---------|----------|---------|---------|
|          | V       | mA      |          | V       | mA      |
| 11:40 AM | 6.1     | 78.5    | 5:00 PM  | 5.25    | 72.1    |
| 12:00 PM | 6       | 74.6    | 5:50 PM  | 5.16    | 71.2    |
| 12:30 PM | 5.87    | 74      | 6:30 PM  | 5.1     | 70.9    |
| 1:00 PM  | 5.71    | 74.1    | 9:30 PM  | 5.08    | 70.6    |
| 2:00 PM  | 5.59    | 73.5    | 3:30 AM  | 5.05    | 70.3    |
| 2:30 PM  | 5.48    | 73.1    | 6:30 AM  | 5.03    | 70.3    |
| 3:00 PM  | 5.44    | 72.9    | 9:30 AM  | 5.02    | 70.1    |
| 3:30 PM  | 5.38    | 72.6    | 12:30 PM | 5.01    | 70      |
| 4:00 PM  | 5.32    | 72.3    | 3:30 PM  | 5.01    | 70      |
| 4:30 PM  | 5.28    | 72.2    | 6:30 PM  | 4.96    | 69.1    |
| 4:40 PM  | 5.27    | 72.2    | 7:30 PM  | 4.96    | 69.1    |
| 4:50 PM  | 5.26    | 72.1    | 8:30 PM  | 4.8     | 68      |
|          |         |         | 9:30 PM  | 4.8     | 68      |

Figure 8: Reading without Solar Backup

| Time     | Voltage | Current | Time     | Voltage | Current |
|----------|---------|---------|----------|---------|---------|
|          | V       | mA      |          | V       | mA      |
| 11:40 AM | 6.1     | 78.5    | 5:10 PM  | 6.1     | 78.5    |
| 11:50 AM | 6.1     | 78.5    | 5:40 PM  | 6.1     | 78.5    |
| 12:00 PM | 6.1     | 78.5    | 6:00 PM  | 6.1     | 78.5    |
| 12:30 PM | 6.1     | 78.5    | 7:30 PM  | 6.1     | 77.5    |
| 1:00 PM  | 6.1     | 78.5    | 10:30 PM | 6.1     | 75      |
| 1:30 PM  | 6.1     | 78.5    | 1:30 AM  | 5.9     | 74.2    |
| 2:00 PM  | 6.1     | 78.5    | 4:30 AM  | 5.8     | 74      |
| 2:30 PM  | 6.1     | 78.5    | 7:30 AM  | 5.8     | 75      |
| 3:00 PM  | 6.1     | 78.5    | 10:30 AM | 6.1     | 78.2    |
| 3:30 PM  | 6.1     | 78.5    | 1:30 PM  | 6.1     | 78.2    |
| 4:00 PM  | 6.1     | 78.5    | 4:30 PM  | 6.1     | 78.2    |
| 4:30 PM  | 6.1     | 78.5    | 7:30 PM  | 6.1     | 78.2    |
| 4:40 PM  | 6.1     | 78.5    | 8:30 PM  | 6.1     | 78.2    |
| 4:50 PM  | 6.1     | 78.5    | 9:30 PM  | 6.1     | 78.2    |
| 5:00 PM  | 6.1     | 78.5    |          |         |         |

Figure 9: Reading with Solar Backup

## 5. CONCLUSION AND FUTURE WORK

This paper is made to provide Solar Backup for Wireless Monitoring of Temperature, Humidity & Light Intensity and the developed system is performing its function as desired. The same can be installed at any work place for monitoring of the parameters and displaying them on a remote PC through wireless communication. Based on results and analysis, we conclude that a prototype system has been successfully tested. Wireless sensor data is being transmitted over three nodes to a single receiver at PC, and displayed on screen. By the use of solar backup we improved the life of the sensor node, very much useful while installing sensor nodes on field.

In the future, the scope of this work can be extended as it can be enhanced by assembling more sensor nodes. It can be used heterogeneous combination of different sensor nodes. As number of nodes are increased then dynamic path allocation can also be implemented by introducing various routing methods. The platform can be used to implement various sensing applications like environment pollution monitoring during peak traffic hours and low traffic hours. The host computer can be interfaced with GSM modem and the results, alarm can be sent to GSM Subscriber.

## 6. REFERENCES

- [1] F. Salvadori, M. de Campos, R. de Figueiredo, C. Gehrke, C. Rech, P. S. Sausen, "Monitoring and Diagnosis in Industrial Systems Using Wireless Sensor Networks", IEEE International Symposium on Intelligent Signal Processing, 2007.
- [2] J. Blumenthal, R. Grossmann, F. Golatowski, and D. Timmermann "Weighted Centroid Localization in Zigbee-based Sensor Networks", Proceedings of IEEE International Symposium on Intelligent Signal Processing, October 2007.
- [3] H. Ramamurthy, B.S. Prabhu, R. Gadh, A.M. Madni, "Wireless industrial monitoring and control using a smart sensor platform", IEEE Sensors Journal, v 7, n 5, May 2007.
- [4] William Stallings, Wireless Communication and Networking, Prentice Hall 2002, ISBN 0-13-040864-6.
- [5] ZigBee Alliance, <http://www.zigbee.org>, 2005

IJournals