

Single-Stage Power Conversion PV-Battery System by Using Fuzzy Logic Control (FLC)

Reena Jain¹, Neelesh Patel²

¹Student of M.Tech Electrical & Electronics Engineering (EEE Deptt.), DIMAT, Raipur (CSVTU University Bhilai)

²Neelesh Patel in DIMAT, Raipur and Electrical & Electronics Engineering (EEE Deptt.), Raipur
1603reenajain@gmail.com
neelesh.patel27@gmail.com

ABSTRACT

The output power of PV module varies with solar irradiation; temperature; loads and it quickly and accurately tracks the sun. For photovoltaic (PV)-battery application, mostly for utility-scale PV-battery application a new converter i.e. Reconfigurable solar converter (RSC) is introduced. The basic concept of the RSC is to employ a single-stage three phase conversion system to perform different operation modes such as dc/ac and dc/dc for solar PV systems with energy storage. This converter solution is appealing for PV-battery application as it minimizes the weight, the number of conversion stages there by reducing the cost, volume and improving efficiency. In this paper fuzzy logic controller (FLC) is used for controlling the Reconfigurable solar converter (RSC) for photovoltaic (PV)-battery application, mostly for utility-scale PV battery application. The main advantage of fuzzy logic control is to eliminate steady state error, harmonic content and improve the system response.

Keywords: - Converter, energy storage, fuzzy logic, photovoltaic (PV), solar.

I. INTRODUCTION

Solar photovoltaic (PV) electricity is not available every time and sometime less available due to the weather conditions and at the time of day. Solar PV electricity output is highly sensitive to shading. When even a small portion of a module, cell or array is shaded, although the remains is in sunlight the output falls vividly. Hence, solar PV electricity output significantly varies. As a result, energy storage such as fuel cells and batteries for solar (PV) systems has drawn and the demand of energy storage for solar PV systems has been significantly increased, since, with energy storage, a solar PV system becomes a stable energy source which results in improving the performance and the value of solar PV systems [1]–[3]. There are different options for integrating energy storage into a utility-scale solar PV system and energy storage can be integrated either in ac or dc side of the solar PV power conversion systems which may consist of multiple conversion stages [4]–[33]. Different integration solutions can be compared with regard to the efficiency, control complexity, storage system flexibility, and the number of power stages etc.

A new converter is introduced in this paper called as Reconfigurable solar converter (RSC) for photovoltaic (PV)-battery application, mostly for utility-scale PV-battery applications. The new converter main concept is to use a single-stage three phase grid-tie solar PV converter to perform dc/dc and dc/ac operations. Assuming that the conventional utility-scale PV inverter system consists of a three-phase voltage source converter and its associated components and the RSC requires additional cables and mechanical switches. The vital concept of the RSC is to use a single-stage three-phase power conversion system to perform different operation modes such PV to battery (dc to dc), as PV to grid (dc to ac), battery to grid (dc to ac), and battery/PV to grid (dc to ac) for solar PV systems with energy storage.

The concept of RSC arose from the fact that energy storage integration for utility-scale solar PV systems makes sense if there is an enough gap or a minimal overlap between the PV energy storage and release time. Figure 1 shows the different scenarios for the PV generated power time and load supply. In case (a), the PV energy is always delivered to the grid and there is no need of energy storage. However, for the cases (b) and (c), the PV energy should be first stored in the battery and then the battery or both battery and PV supply the load and in cases (b) and (c), integration of the battery has the highest value and the RSC provides significant benefit over other integration options when there is the time gap between generation and consumption of power.

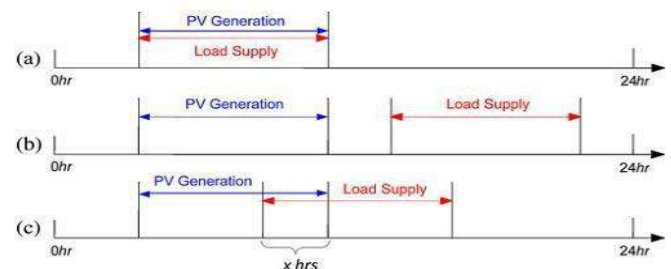

Figure 1. Scenarios of PV generation and load supply.

In this paper, we deal with the proper algorithm in order to extract maximum power with fuzzy logic control (FLC) of

generator side converter and thus control of generator speed was used [3]. The main advantages in using fuzzy logic controller against standard PI controllers are pointed out in better response to frequently changes in wind speed. Section II introduces the proposed RSC circuit, different modes of operation, and benefits of system. In Section III, a control scheme of the RSC is introduced and necessary design considerations and modifications to the conventional three phase PV converter are discussed. Section IV verifies the RSC with simulation results that demonstrate the attractive performance characteristics with FLC. Section V summarizes and concludes the approach.

II. RSC CASE STUDY

A. Introduction

The schematic of the proposed RSC system is presented in Figure 2. The RSC has some modifications to the conventional three-phase PV inverter system.

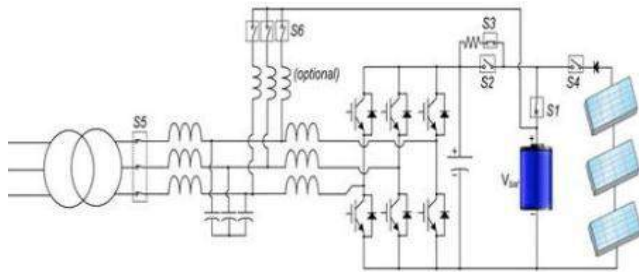

Figure.2 Schematic of the proposed RSC circuit

These modifications allow the RSC to include the charging function in the conventional three phase PV inverter system. Assume that the conventional utility-scale PV inverter system consists of a three-phase voltage source converter and its associated components and the RSC requires additional cables and mechanical switches, as shown in Figure 2. Optional inductors are included if the ac filter inductance is not enough for the charging purpose.

B. Operation Modes of the RSC

Different operation modes of the RSC are presented in Figure 3. In Mode 1, the PV is connected to the grid through a dc/ac operation of the converter with possibility of maximum power point tracking (MPPT) control and the switches S1 and S6 remain open. In Mode 2, the battery is charged with the PV panels through the dc/dc operation of the converter by closing the switch S6 and opening the switch S5 and in this mode, the MPPT function is performed; therefore, maximum power is generated from PV. In Mode 3, both the PV system and battery provide the power to the grid by closing the switch S1 and in this mode, the dc voltage that is the same as the PV voltage is enforced by the battery voltage; therefore, MPPT control is not possible. In Mode 4, it is an operation mode that the energy stored in the battery is delivered to the grid. There is another mode that is the Mode 5, in this mode the battery is charged from the grid. This mode is not shown in Figure 3.

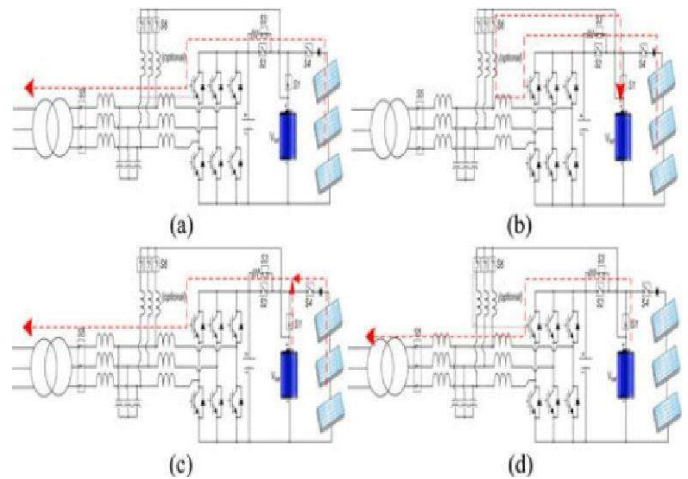

Figure3. All operation modes of the RSC. (a) Mode 1—PV to grid (b) Mode 2—PV to battery (c) Mode 3—PV/battery to grid (d) Mode 4—battery to grid

These modifications allow the RSC to include the charging function in the conventional three phase PV inverter system. Assuming that the conventional utility-scale PV inverter system consists of a three-phase voltage source converter and its associated components, the RSC requires additional cables and mechanical switches, as shown in Fig. 2. Optional inductors are included if the ac filter inductance is not enough for the charging purpose.

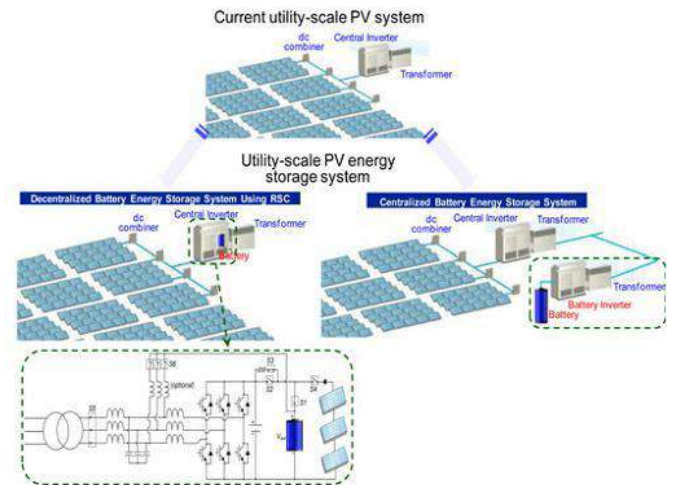

Figure 4. Utility-scale PV-energy storage systems with the RSC and the current State-of-the-art solution.

C. Benefits of Solar PV Power Plant with the RSC Concept

The concept of RSC provides significant benefits to utility-scale solar PV power plants. The current technique is to integrate the energy storage into the ac side of the PV solar system. An example of commercial energy storage solutions is the ABB distributed energy storage (DES) solution that is a

complete package up to 4 MW, which is connected to the grids directly and, can be utilized as a mean for peak shifting in solar PV power plants [33].

The concept of RSC allows not only the system owners to possess an expandable benefit that help them to plan and operate the power plant accordingly but also manufacturers to offer a cost-competitive decentralized PV energy storage solution with the RSC. Figure 4 shows examples of the PV energy storage solutions with the RSC and the current technique.

The financial and technical benefits that the RSC solution is able to provide are more apparent in larger solar PV power plants. Specially, a large solar PV power plant using the RSCs can be controlled more efficiently and its power can be dispatched more cost-effectively because of the flexibility of operation. Though, different system controls as shown in Figure 5 can be proposed based on the requested power from the grid operator P_{req} and available generated power from the plant P_{gen} .

These two values are being a result of an optimization problem (such as unit commitment methods) serves as variables to control the solar PV power plant accordingly or in other word the system response to the request of the grid operator and different system control schemes can be realized with the RSC-based solar PV power plant as follows:

- 1) System control 1 for $P_{gen} > P_{req}$;
- 2) System control 2 for $P_{gen} < P_{req}$;
- 3) System control 3 for $P_{gen} = P_{req}$;
- 4) System control 4 for charging from the grid (Operation Mode 5).

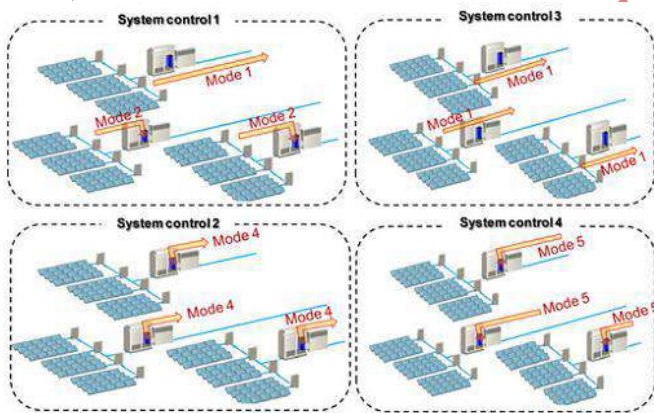

Figure 5. Example of different system operation modes of a RSC-based solar PV power plant.

III. CONTROL OF RSC

A. Control of the RSC in the DC/AC Operation Modes (Modes 1, 3, 4, and 5)

The RSC dc/ac operation is utilized for delivering power from PV to grid (mode1), battery to grid (mode3), PV and battery to grid (mode4), and grid to battery (mode5). In this the RSC perform the MPPT algorithm to deliver maximum power from the PV to the grid. As same as the conventional PV inverter

control, the control of RSC is implemented in the synchronous reference frame. The proportional-integral current control is employed, in the synchronous reference frame. In a reference frame rotating synchronously with the fundamental excitation and the FES is transformed into dc signals. As a result, the regulator current form the innermost loop of the control system is able to regulate ac currents over a wide range of frequency with high bandwidth and zero steady-state error. For the pulse width modulation (PWM) scheme, the space vector PWM scheme is utilized. Figure 6 shows the overall control block diagram of the RSC in the dc/ac operation. For the operation of dc/ac with the battery, the RSC control should be coordinated with the battery management system (BMS), which is not shown in Figure 6.

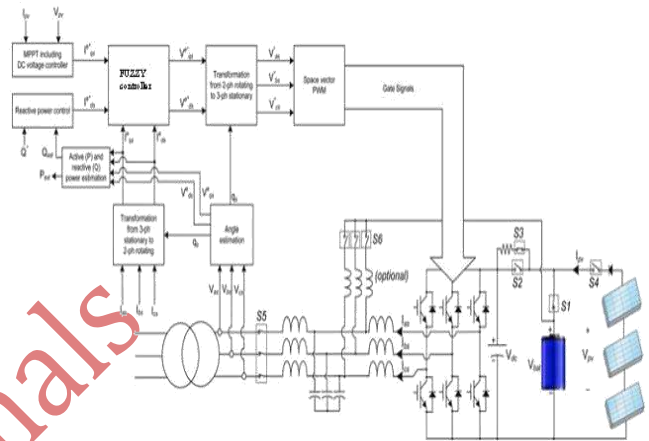

Figure 6. Overall control block diagram of the RSC in the dc/ac operation.

B. Control of the RSC in the DC/DC Operation Mode (Mode 2)

The RSC dc/dc operation is also utilized for delivering the maximum power from the PV to the battery. The RSC in the dc/dc operation, a boost converter is used, that controls the current flowing into the battery. For the PV-battery systems, Li-ion battery has been selected in this research. Li-ion batteries require a constant voltage type of charging algorithm and constant current. In other words, a Li-ion battery should be first charged at a set current level until it reaches its final voltage. At the final voltage level, the charging process should be switch over to the constant voltage mode, and provide necessary current to hold the battery at this final voltage. Therefore, the dc/dc converter performing charging process and it must be capable of providing stable control for maintaining either voltage or current at a constant value, depending on the battery state. Typically, a few percent capacity losses occur by not performing constant voltage charging. However, it is not rare to use only current constant charging to simplify the charging control and process and the later has been used to charge the battery. Therefore, from the control purpose, it is enough to control only the inductor

current. So, the dc/dc operation of RSC performs the MPPT algorithm to deliver maximum power from the PV to the battery. For the operation of dc/dc with the battery, the RSC control should be coordinated with the battery management system (BMS), which is not shown in Figure 7.

Figure 7 shows the overall control block diagram of the RSC in the dc/dc operation

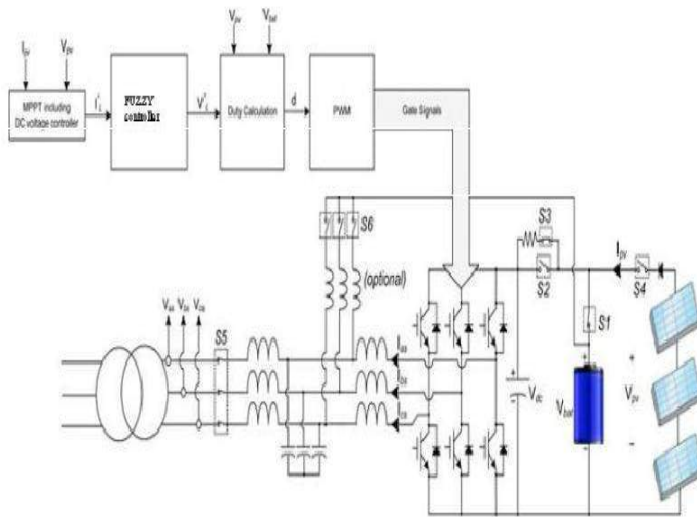

Figure 7. Overall control block diagram of the RSC in the dc/dc operation

Table I. Inductance value of a coupled three-phase inductor in the dc/dc operation

DC Application	Inductance value
Only A	1.42 mH
Only B	1.58 mH
A & C	0.50 mH
A & B & C	0.13 mH

C. Design Considerations and Modifications to the Conventional Three-Phase PV Converter

The most necessary requirement of this project is that a new power conversion solution for PV-battery systems must have minimum modifications and complexity to the conventional three-phase solar PV converter system. Hence, it is necessary to study how a three phase dc/ac converter operates as a dc/dc converter and what modification must be made to convert. For the high-power three-phase PV converter, a LCL filter is used and the dc/dc operation of the RSC is expected to use the inductors which are already available in the LCL filter. There are mainly two types of inductors are there:

- (1) coupled three-phase inductor and
- (2) Three single-phase inductors.

In this project a three single-phase inductor are utilized in

the RSC circuit and while using coupled three-phase inductor in the dc/dc operation causes a major drop in the inductance value due to inductor core saturation.

Table I shows an example of inductance value of a coupled three-phase inductor for the dc/dc operation, which show significant drop in the inductance value. The decrease in inductance value requires inserting additional inductors for the dc/dc operation which has been marked as “optional” in Figure 2. To avoid extra inductors, only one phase can perform the dc/dc operation. But, when only one phase starts performing that is for phase B, the dc/dc operation with only either upper or lower three insulated gate bipolar transistors (IGBTs) are turned OFF as paired switching. The circulating current occurs in phases A and C through filter capacitors, switches, and the coupled inductor, resulting in high ripple current in phase B, as shown in Figure 8.

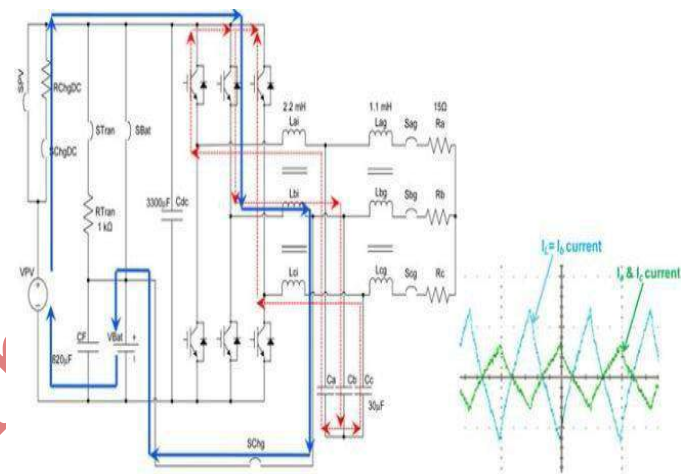

Figure 8. Circulating current path if one phase is used for the dc/dc operation of the RSC with a coupled three-phase inductor

Thus in the dc/dc operation to prevent the circulating current, the following two solutions are proposed;

- 1) All unused upper and lower IGBTs should be turned OFF;
- 2) The three single phase inductors is used instead of coupled inductor

While using three single-phase inductors so it possible to use all three phase legs for the dc/dc operation. There are two methods to utilize all three phase legs for the dc/dc operation:

- 1) Synchronous operation.
- 2) Interleaving operation

In the first operation, all the three phase legs can operate synchronously with their own current control. In synchronous operation case, the battery will be charged with a higher current. This increase a more rapidly charging time due to higher charging current capability. Therefore, each phase operates with higher ripple current. The higher ripple current flowing into the battery and capacitor and it also has negative effects on the lifetime of the battery and capacitors. To overcome the above mentioned difficulty associated with the synchronous operation, phases B and C can be shifted by applying a phase offset.

In the second interleaving operation using three phase legs, phases B and C is shifted by 120° and 240° respectively. In the interleaving operation, the inductor current control requires a different inductor current scheme, as shown in Figure 9.

Generally, for digital control of a dc/dc converter, the inductor current is usually sampled at either the beginning or center point of PWM to capture the average current that is free from switching noises. For 2-phase interleaving, the two phases are 180° apart; there is no need to change the sampling scheme, while the average inductor currents for both phases can be obtained with the conventional sampling scheme shown in Figure 9(a). But, for three-phase interleaving, a customized sampling scheme is required to measure the average currents for all three phases. Then, the sampling points for phases B and C must be shifted by 120° and 240° , respectively as shown in Figure 9(b) which may imply that computation required inductor current control for each phase should be done asynchronously. By using the interleaving operation reduces the ripples on the charging current flowing into the battery. So, the filter capacitance value can be reduced significantly.

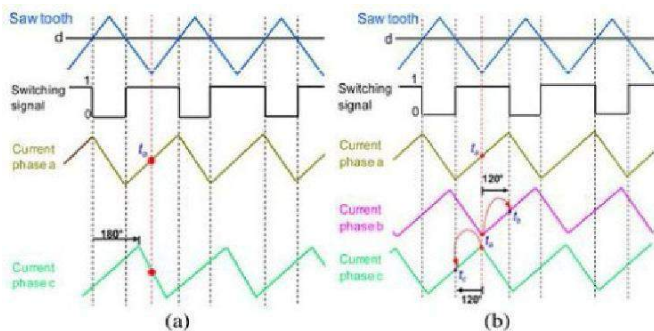

Figure9. Inductor current sampling schemes in the interleaving operation. (a) Two-phase interleaving. (b) Three-phase interleaving

D. Mode Change Control

The RSC vital concept is to use a single power stage circuit to perform different operation modes such as PV to battery (dc to dc) and PV to grid (dc to ac) for PV systems with energy storage. To change a mode, the RSC should be Reconfigurable by either connecting or disconnecting components such as the battery through contactors. It is very necessary to understand the dynamics of the RSC circuit. Particularly, it is important to understand the time response relay such as how long it takes for a relay to completely open or close. Thus, all the relays performance characteristics used in the RSC circuit must be investigated with their data sheets. All the relays which are used in the RSC circuit have a maximum operating time equal to or smaller than 50ms. All the switching process which occurs during the change of mode is done under zero or nearly zeros current except in case of fault. To verify the operating time of the relays given in the datasheet, a test of one of the

relays is done. The operating time of the relay is investigated for SC hg DC in Figure 8 during pre-charging of the inverter capacitors. As soon as the voltage is applied to the relay, it just takes 20 ms for the relay to be fully closed.

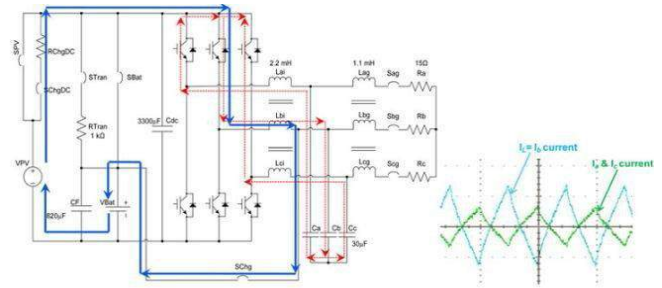

Figure8. Circulating current path if one phase is used for the dc/dc operation of the RSC with a coupled three-phase inductor

For all relays used in the RSC circuit, 80 ms is used for switching transient time for both releasing and closing. The RSC mode change control highest layer is shown in Figure 11. This layer consists of normal operation, fault reset and fault detection. The basic fault detection such as detecting over-voltage and over-current and fault management like turning off PWM signals is placed inside the converter control executed in the inner most control loop. In this manner, fast fault detection and protection is possible. In common, shutting down all PWM signals is able to clear the fault and all relays are required to be opened. If the system is operating at a normal, then the status of the system will be “Normal Condition” and the fault flag is set by detecting a fault, the status of the system is “Fault Condition.” In fault condition, all relays as well as PWM signals are turned off.

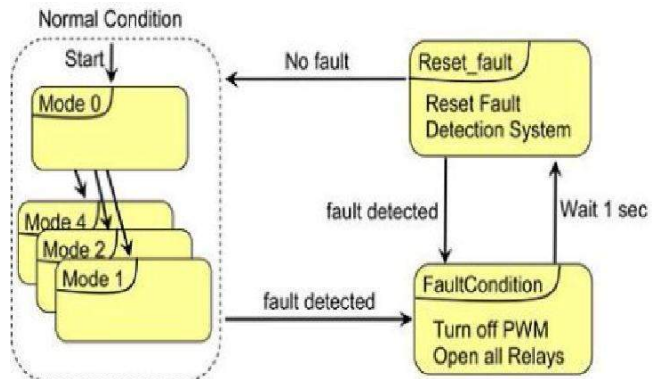

Figure11. Highest layer of the RSC mode change control.

When the system is in “Fault Condition,” the RSC mode change control tries to clear a fault in every 1s and if the fault cannot be cleared, the system will remain in the “Fault Condition.” If the fault is cleared, then the system will be in “Normal Condition.” The system always starts with Mode 0 in “Normal Condition,” which is the shutdown mode. After this, it allows the RSC to move to a new mode safely, when the fault is cleared. The control topology inside “Normal Condition” is shown in Figure 12. The mode of RSC control can be changed in any mode from the present mode. If Modes 1 or 2 are commanded, the relay “SC hg DC” will be closed

and the state will change from Mode 0 to PVCharge1 and this will charge the capacitor Cdc through the resistor RChg DC. As soon as the capacitor dc voltage reaches 98% of the source voltage, the state will change to PVCharge2 and this will also close relay SPV, though the relay SChg DC will remain closed, since no new action refers to this relay. As to make sure that the relay SPV is fully closed, a delay of 80 ms is applied and a relay switching transient time is used.

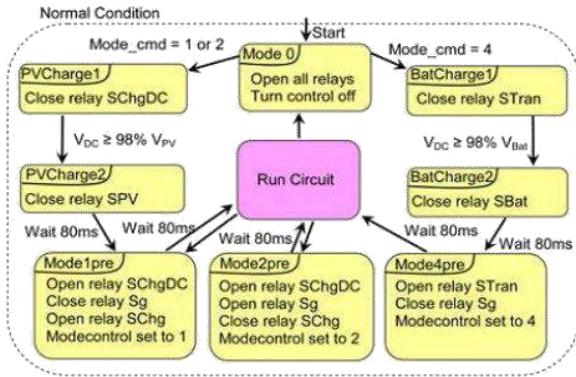

Figure 12. States inside Normal Condition.

The procedure of Mode 1 is described in Figure 12. Suppose, the current state is Mode1pre. As the relay SChg DC is opened, so that the pre-charging procedure has been completed. The three grid switches Sag, Sbg, and Scg are closed and so the load is connected to the RSC. Moreover, the relay SChg is opened and the control is set to Mode 1, which is a dc/ac control. As the relay switching is included in the state Mode1pre, 80 ms of a delay is necessary to move to the state of Run Circuit. When the previous mode is 1, it is probably to directly move to Mode2pre. This would avoid the pre-charging process as the capacitors of the inverter are required to be connected to the PV side in both the modes. All the actions from Mode2pre are executed shown in Figure 12. After 80 ms delay, the state will move to Run Circuit shown in Figure 13. The previous Mode 2 and the Mode 1, the state will directly moves from PWMOFF to Mode1pre and back to Run Circuit by avoiding the pre-charge process. The set up of Mode 4 is different from Modes 1 and 2, since it connects the battery to the inverter instead of connecting the PV battery to it. Although the procedure of pre-charging is quite the same done for the mode 1. Only different is the relays are used—STran is used for charging the capacitor Cdc through resistance RTran and relay SBat for directly connects the battery to the inverter. After that, the state Mode 4 pre closes the grid switches and sets the mode control to number 4, which is again a dc/ac control. After the state Mode 4 pre, the state will change to Run Circuit. Going from Modes 1 and 2 to Mode 4 or vice versa is not as easy because the mode change between Modes 1 and 2. The dc voltage has to be changed to either the battery voltage (coming from Mode 1 or 2) or the PV voltage (coming from Mode 4), which makes the mode change control to use Mode 0 for transition. It does not mean that the circuit needs to be fully de-energized, since the pre-charging resistances limit the current.

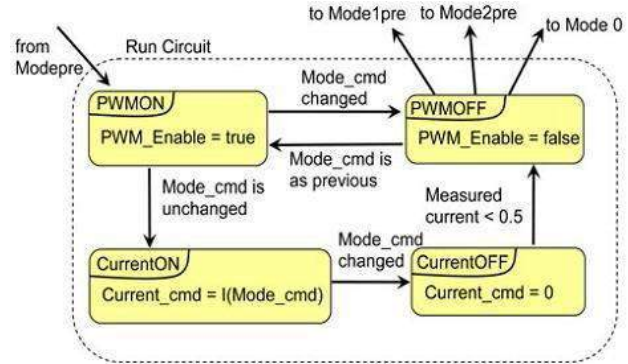

Figure 13. Control topology inside Run Circuit.

E. Fuzzy Logic Controller:

Fuzzy logic control (FLC) is a non-mathematical decision algorithm which is based on an operator’s experience. This type of control strategy is suited for nonlinear Systems.

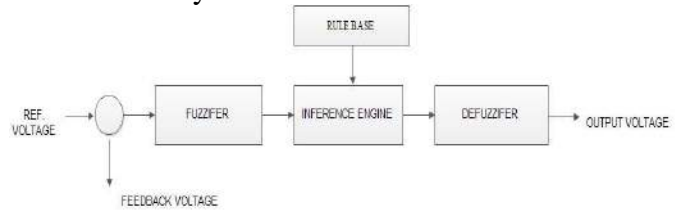

Figure 14. The general structure of Fuzzy Logic Controller

Fuzzy logic control (FLC) contains of three main basic parts: Fuzzification, Base rule, and Defuzzification. FLC have two inputs which are: error and the change in error, and one output. The Fuzzy Controller structure is shown in Figure 14. The role of each block is as follows: Fuzzifier converts a numerical variable into a linguistic label. In the closed loop control system, the error (e) between the reference voltage and the output voltage and the rate of change of error (del e) can be labeled as zero (ZE), positive small (PS), negative small (NS), etc. In the actual, measured quantities are real numbers (crisp). The FLC has two inputs, i.e., the error and the rate of change of error. On based of these two inputs, the FLC takes a decision and applied a field voltage which is taken as the output and directly applied to the field winding of generator. A triangular membership functions be used for the controller Rule base stores the data that defines the input and the output of the fuzzy sets, as well as describe the fuzzy rules i.e. the control strategy. In this paper, Mamdani method of fuzzy logic control is used. The Inference engine which applies the fuzzy rules to the input fuzzy variables to obtain the output values. Defuzzifier achieves the output signals which are based on the output fuzzy sets obtained as the result of fuzzy reasoning. Centroid defuzzifier is used in this paper.

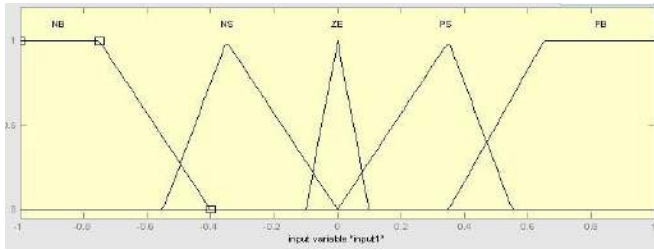

Figure 14.a. Membership function of error

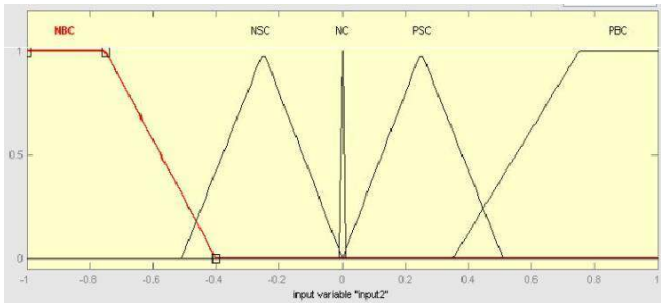

Figure 14.b. Membership function of change of error

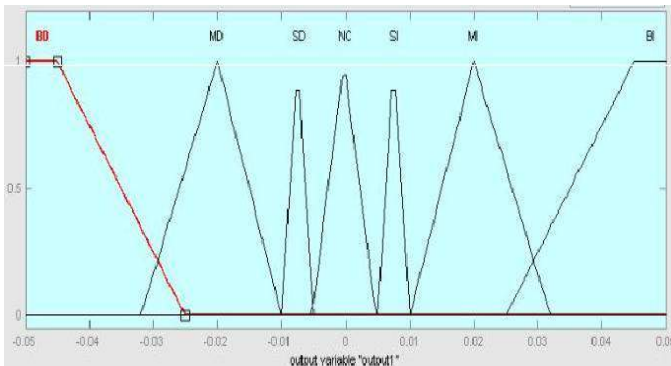

Figure 14.c. Membership function of output

IV. SIMULATION VERIFICATION OF THE RSC CIRCUIT

A. Simulation Setup

The RSC circuit diagram shown in Figure 2 is used to verify the RSC concept in MATLAB/SIMULINK and shows the components used in the RSC circuit. In Figure 2, the conventional grid-tie PV inverter is connected to the grid and delivers the power from the PV to the grid. Thus, the conventional grid-tie PV inverter requires grid synchronization and power factor control functions.

Table III: Lithium-ion k2 battery parameters

Battery capacity	Kwhr/Ahr	5.9/51.2
Battery nominal voltage	V	115.2
Min battery voltage	V	90
Max discharge current	A	52
Max pulse discharge current	A	150 (<2s)
Max charging voltage	V	132
Max charging current	A	10

For RSC verification, the abovementioned functions are not implemented and tested. While the RSC uses the same algorithms for those functions as the conventional grid-tie PV inverter, it is not necessary to verify them. Thus, the RSC circuit is connected to a passive load. The conventional grid-tie PV inverter as well as performs the MPPT to extract the available maximum power from the PV. Therefore, verification of the RSC circuit is done with a controllable dc power supply, which is shown in Figure 2. As represented in Figure 2, the RSC consists of diodes and six IGBTs that have the rating of 100A and 1.2 kV peak. It has a pre-charging circuit to limits an inrush current flowing into the capacitors of the three-phase inverter, when the dc power supply is connected to the three-phase inverter. The filter capacitor is used to reduce ripples voltage and current for the batteries. In this Circuit, there is also a voltage balancing circuit that limits an inrush current flowing into the filter capacitors of the batteries, when the battery system including the battery filter capacitors is primarily connected to the inverter. There are three relays which are used for battery charging in the dc/dc operation. The rating of relay is determined by the battery charging current requirement. As mentioned previously, a passive load is used for the RSC verification. The maximum power of a passive load is about 3 kW under the air-cooled condition. At the top, the RSC consisting of six IGBTs, six diodes filter inductors, capacitors, relays, and wires. At the bottom, the energy storage device, the K2 Li-ion battery. The specification of the K2 battery is described in Table III. The K2 battery has its own BMS. The BMS measures the state of the battery cell voltages, the current flowing into or out of the

battery, and temperatures and BMS also determines the battery operating status such as normal, warning, and error. BMS also uses the relays to protect the battery system and prevent them from any damage. The battery system includes a pre-charging circuit to limit current flowing from the batteries into the capacitors that is connected to the battery in parallel for a filtering purpose. The control algorithms of the RSC are implemented with MATLAB/SIMULINK. The performance of the RSC in different operating modes has been tested extensively. In the following, the performance analysis of selected modes of operation is shown in Figure 15.

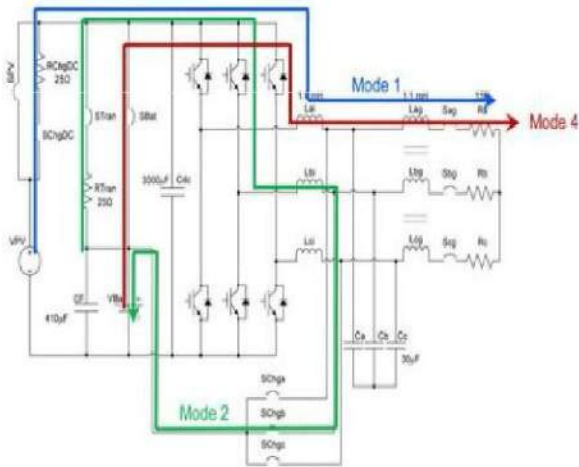

Figure15. Different operation modes tested in the lab.

B. Performance Investigation of the Dc/Ac Operation Modes

Figure16 shows the steady-state performance of dc/ac control for Mode 1. In Mode 1test, the voltage on the dc side VDC of the inverter is set as 200 V. The current reference is set to a 5A peak for the frequency of 60 Hz. As shown in Figure 16, a satisfactory steady state performance is obtained. Figure17 shows the steady-state performance of dc/ac control for Mode 4. In the test, the voltage on the dc side VDC of the inverter is set to 118 V which is a battery voltage. The current reference is set to a 3A peak for the frequency of 60 Hz. As shown in Figure 17, the satisfactory dc/ac steady-state performance is obtained. In Figure 17, the current flowing into the battery is exhibited. The average battery charging current is 1.8 A and the battery charging current has about 0.85A pk-pk current ripple with the frequency of 60 Hz.

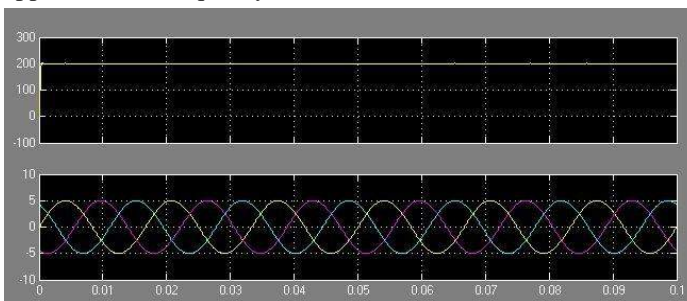

Figure16. Steady-state performance of dc/ac control in

Mode 1

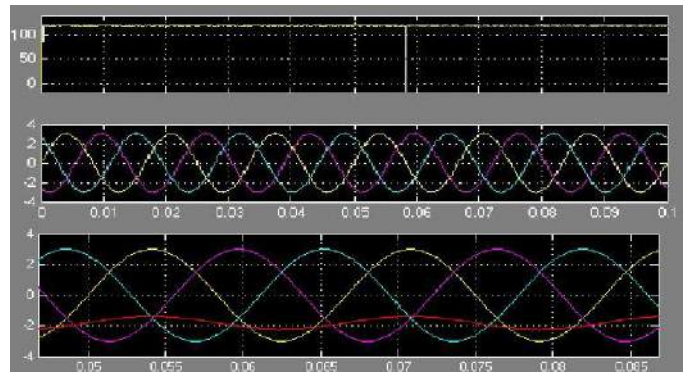

Figure17. Steady-state performance of dc /ac control in Mode 4

C. Performance Investigation of the DC/DC Operation Mode

In Mode 2 i.e. PV to battery, the three-phase inverter is used as a dc/dc converter. As a three-phase inductor is used for the filter inductor to the inverter side. When only phase B is utilized for the dc/dc operation with only either upper or lower three IGBTs are turned off as paired switching, the circulating current occurs in phases A and C through the coupled inductor, filter capacitors and switches, resulting in high ripple current in phase B, as shown in Figure 18(a).

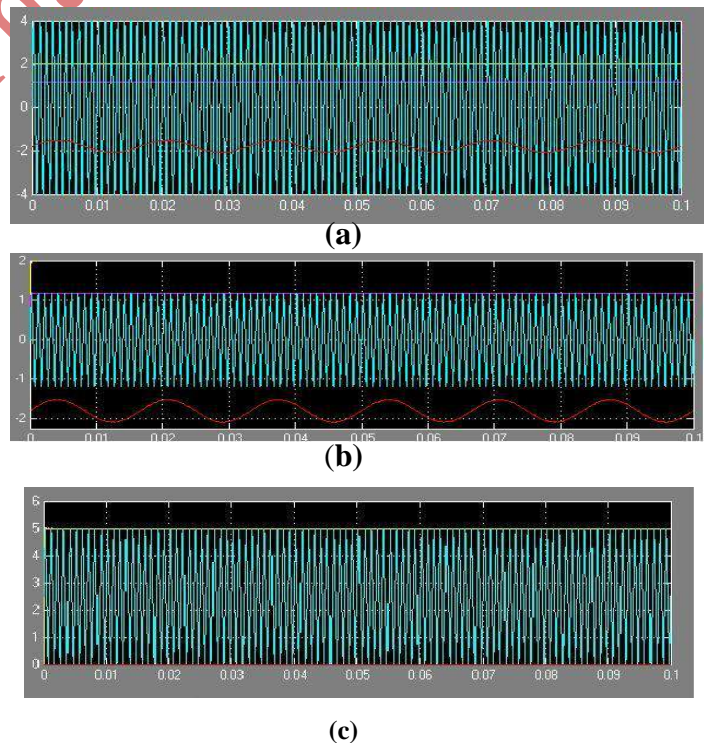

Figure 18. Steady-state performance of the RSC with single-phase operation in the dc/dc mode (Mode2). (a) When switches unused are not turned OFF. (b) When switches unused are turned OFF. (c) When three single-phase inductors are used

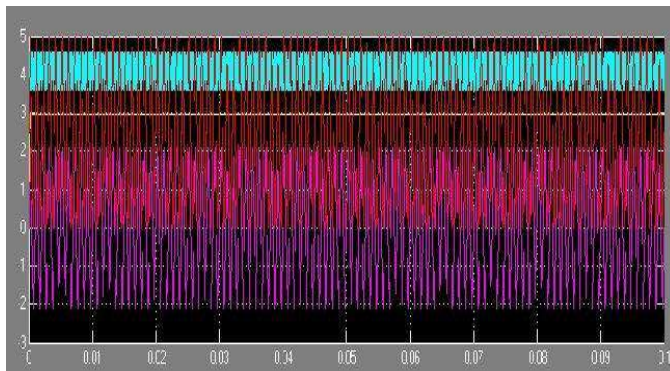

Figure 19. Steady-state capacitor and battery current for single phase operation using three single-phase inductors in the dc/dc operation.

To solve the abovementioned problem, as explained, two solutions are proposed. First, the switches which are unused should be turned off and so the phase current has very lower ripple as presented in Figure 18(b). In phase B, the average current is 5 A with a ripple current of $5 A_{pk-pk}$, while the current in phases A and C remains zero. So there is no circulating current in the phase A and C. The second solution is to use three single-phase inductors in the RSC circuit. In this mode, the circulating current is vanished automatically due to the single-phase operation. The result of the test is shown in Figure 18(c), the current in the other phase's remains zero while the battery is charged.

Figure 19 show the current going into the battery for the test shown in Figure 18(c). In phase B, the average current and battery is about 5 A. The phase B ripple current is $5 A_{pk-pk}$ and the battery ripple current is $1.4 A_{pk-pk}$. The capacitor ripple current is about $4.2 A_{pk-pk}$. Using three single-phase inductors enable the RSC to use all three phase legs in the dc/dc operation. As before it is discussed that, there are two methods to use all three phase legs for the dc/dc operation. In the first loom, all three phase legs operate synchronously with their own current controls. Figure 20 shows the waveforms of the synchronous operation. The sum of all three phase currents is 5A that means that each phase carries one-third of it. Hence, it is likely to charge the battery with a higher current, which leads to a faster charging time and each phase current shows the ripple current of $5 A_{pk-pk}$. The battery current has ripple current of $4 A_{pk-pk}$ and the capacitor current shows the ripple current of $12 A_{pk-pk}$ which is approximately three times as high as the ripple current of the battery charging using a single phase leg.

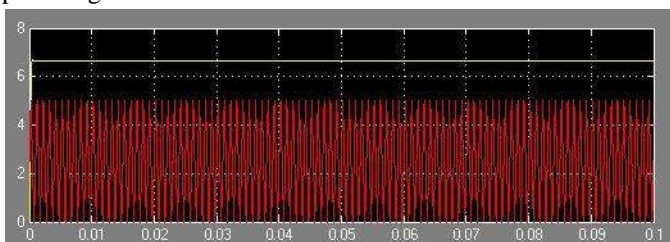

Figure 20. Steady-state performance of the RSC with three phase synchronous operation in the dc/dc mode (Mode2)

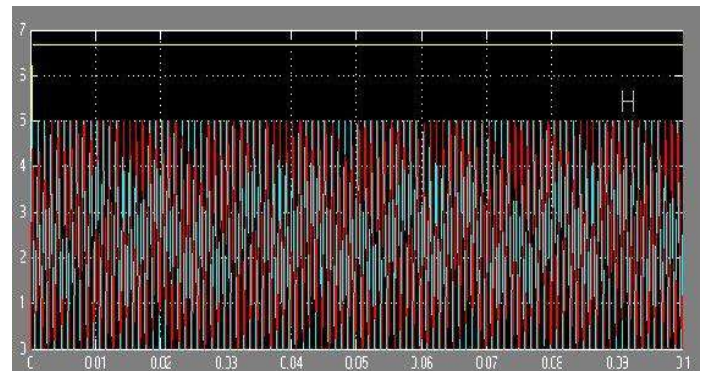

Figure 21. Steady-state performance of the RSC with three phase interleaved operation in the dc/dc mode (Mode2).

As higher ripple current flowing into the capacitor and battery will have negative effects on the lifetime of the battery and capacitors. As before discussed, using the interleaving operation can reduce the ripples on the charging current flowing into the battery. As shown in Figure 21, the battery current has a current ripple of $0.5 A_{pk-pk}$ and the capacitor current has a ripple current of $1.5 A_{pk-pk}$ when the sum of all three phase currents and average battery current is 5 A. These ripples current are one-third of the ripple currents for dc/dc control using a single phase leg and one-eighth of the ripple currents for dc/dc control using all three phase legs in synchronous operation, which means significant ripple reduction is achieved by interleaving operation

D. Performance Investigation of Mode Change

Mode change control is the most vital aspect of the RSC operation. To apply the mode change control, MATLAB/SIMULINK state flow is used. Figure 22 shows the simulation results of mode change control. As mentioned before, only Mode 0 (Shutdown), Mode 1 (PV to Grid), Mode 2 (PV to Battery), and Mode 4 (Battery to Grid) are tested in MATLAB/SIMULINK.

All mode changes show satisfactory performance in both transient and steady states. As in Section III already discussed, the mode change either from or to Mode 4 is not as simple as the mode change between Modes 1 and 2, since the dc voltage must be changed to either the battery voltage or the PV voltage. In the transition mode either to or from Mode 4, Mode 0 is used for transition [see Figures. 22(h) and 22(i)]. After Mode 0 as transition, the dc capacitor is either discharged or charged through the pre-charging resistance. Thus, the dc voltage is changed to either the battery voltage or the PV voltage, as verified in Figure 22.

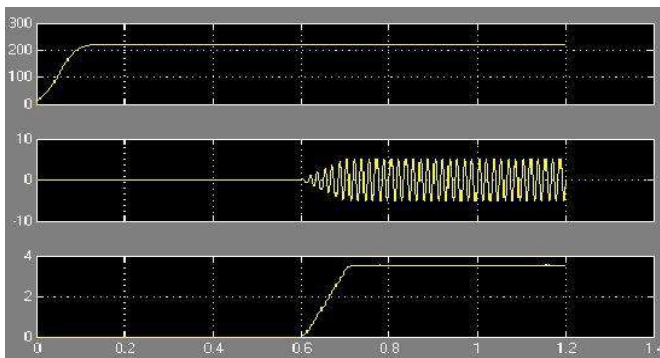

Figure a

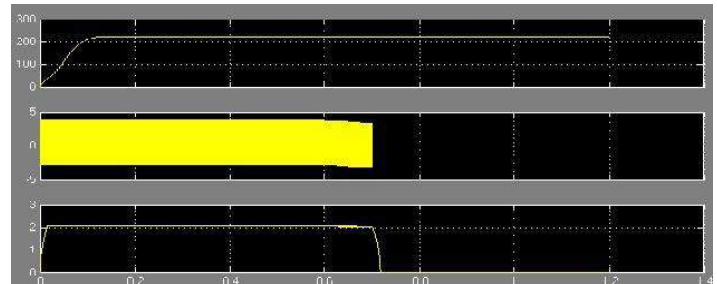

Figure e

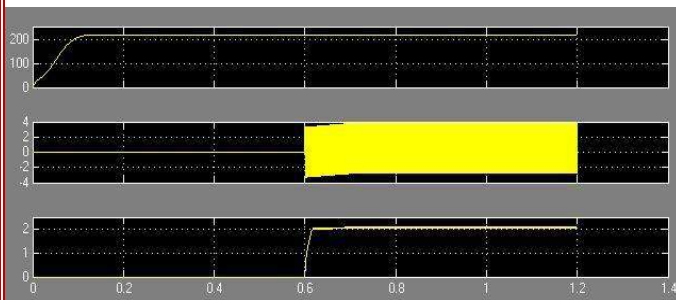

Figure b

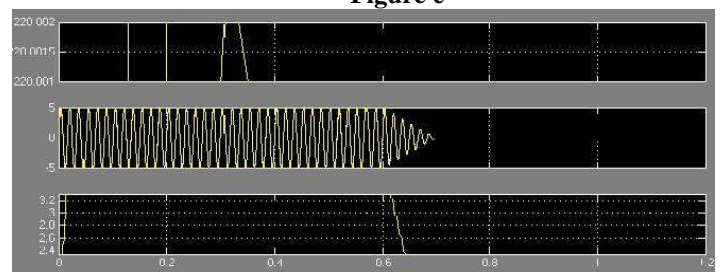

Figure f

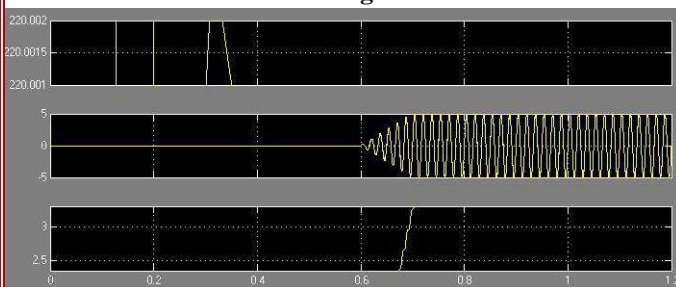

Figure c

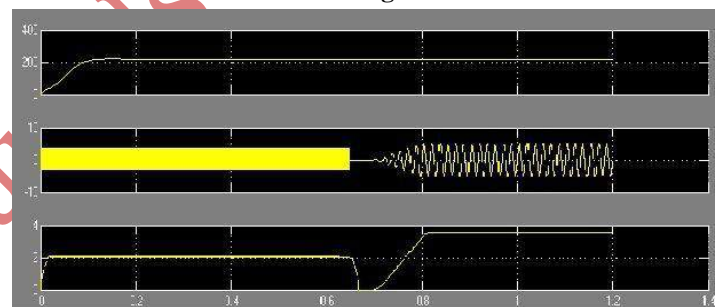

Figure g

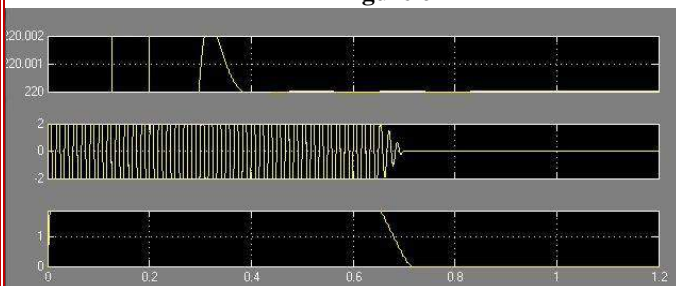

Figure d

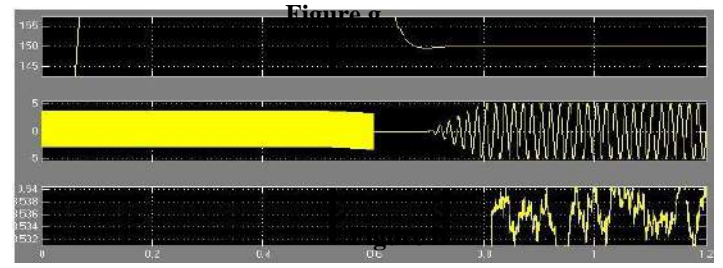

Figure h

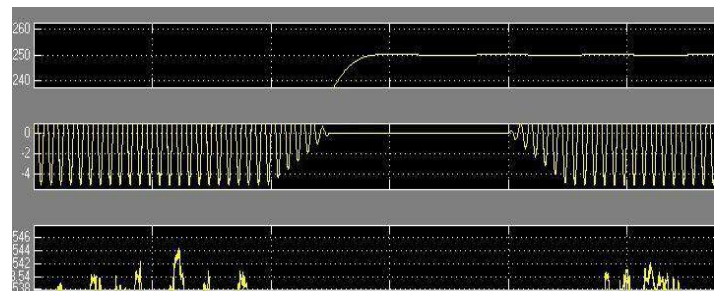

Figure i

Figure 22. Transient performance of mode change.

(a) Modes 0 to 1. (b) Modes 0 to 2. (c) Modes 0 to 4. (d) Modes 1 to 0 and 0 to 2. (e) Modes 2 to 0. (f) Modes 4 to 0 and 0 to 2. (g) Modes 2 to 1. (h) Modes 2 to 4 and 4 to 0 and 0 to 2. (i) Modes 4 to 1.

V. CONCLUSION

This paper have presented a new converter called RSC for PV-battery application, particularly for utility-scale PV-battery application using fuzzy logic control for Recon Figureurable solar converter (RSC). The main concept of the RSC is to use a single power conversion system to perform different modes of operation such as PV to grid (dc to ac), PV to battery (dc to dc), battery to grid (dc to ac), and battery/PV to grid (dc to ac) for solar PV systems with energy storage. The RSC concept provides important benefits to system planning of utility-scale solar PV power plants. The current state of the-art technology is to integrate the energy storage into the ac side of the solar PV system. Thus, the solution is very attractive for PV-battery application, as it minimizes the number of conversion stages, thereby improving efficiency and reducing cost, volume, and weight. Thus, the results confirm that the fuzzy based

RSC is the best solution for PV-battery power conversion systems. From the control point of view, it is just enough to control only the inductor current. Similar to the dc/ac operation, the RSC performs the MPPT algorithm to deliver maximum power from the PV to the battery in the dc/dc operation.

REFERENCES

- [1] U.S. Department of Energy, "Solar energy grid integration systems-energy storage (SEGIS-ES)," May 2008.
- [2] H. Konishi, T. Iwato, and M. Kudou, "Development of large-scale power conditioning system in Hokuto mega-solar project," in Proc. Int. Power Electron. Conf., 2010, pp. 1975–1979.
- [3] J. H. Enslin and D. B. Snyman, "Combined low-cost, high efficient inverter, peak power tracker and regulator for PV applications," IEEE Trans. Power Electron., vol.6, no. 1, pp. 73–82, Jan. 1991.
- [4] H. Ertl, J. W. Kolar, and F. Zach, "A novel multicell dcac converter for applications in renewable energy systems," IEEE Trans. Ind. Electron., vol. 49, no. 5, pp. 1048–1057, Oct. 2002.
- [5] C. Zhao, S. D. Round, and J. W. Kolar, "An isolated three-port bidirectional dc/dc converter with decoupled power flow management," IEEE Trans. Power Electron., vol. 23, no. 5, pp. 2443–2453, Sep. 2008.
- [6] M. Bragard, N. Soltau, R. W. De Doncker, and A. Schiemgel, "Design and implementation of a 5 kW photovoltaic system with Li-ion battery and additional dc/dc converter," in Proc. IEEE Energy Convers. Congr. Expo. 2010, pp. 2944–2949.
- [7] W. Li, J. Xiao, Y. Zhao, and X. He, "PWM plus phase angle shift control scheme for combined multiport dc/dc converters," IEEE Trans. Power Electron., vol. 27, no. 3, pp. 1479–1489, Mar. 2012.
- [8] N. Benavidas and P. Chapman, "Power budgeting of a multiple-input buckboost converter," IEEE Trans. Power Electron., vol. 20, no. 6, pp. 1303–1309, Nov. 2005.
- [9] P. Barrade, S. Delalay, and A. Rufer, "Direct Sustainable Energy," vol. 3, no. 2, pp. 283–294, Apr. 2012.
- [10] S. J. Chiang, K. T. Chang, and C. Y. Yen, "Residential photovoltaic energy storage system," IEEE Trans. Ind. Electron., vol. 45, no. 3, pp. 385–394, Jun. 1998.
- [11] Z. Zhao, M. Xu, Q. Chen, J. Lai, and Y. Cho, "Derivation, analysis, and implementation of a boost-buck converter-based high-efficiency PV inverter," IEEE Trans. Power Electron., vol. 27, no. 3, pp. 1304–1313, Mar. 2012.
- [12] C. Ho, H. Breuninger, S. Pettersson, G. Escobar, L. Serpa, and A. Coccia, "Practical design and implementation procedure of an interleaved boost converter using SiC diodes for PV applications," IEEE Trans. Power Electron., vol. 27, no. 6, pp. 2835–2845, Jun. 2012.
- [13] M. Bragard, N. Soltau, R. W. De Doncker, and A. Schiemgel, "Design and implementation of a 5 kW PV system with Li-ion battery and additional dc/dc converter," in Proc. IEEE Energy Convers. Congr. Expo., 2010, pp. 2944–2949.
- [14] F. Ding, P. Li, B. Huang, F. Gao, C. Ding, and C. Wang, "Modeling and Simulation of grid connected hybrid PV/battery distributed generation system," in Proc. China Int. Conf. Electr. Distrib., 2010, pp. 1–10.
- [15] S. Jain and V. Agarwal, "An integrated hybrid power supply for distributed generation application fed by non conventional energy sources," IEEE Trans. Energy Convers., vol. 23, no. 2, pp. 622–631, Jun. 2008.
- [16] J. Jung and A. Kwasinski, "A multiple input SEPIC with bidirectional input for modular distributed generation and energy storage integration," in Proc. IEEE Appl. Power Electron. Conf. Expo., Mar. 2011, pp. 28–34.
- [17] L. Ma, K. Sun, R. Teodorescu, J. M. Guerrero, and X. Jin, "An integrated multifunction dc/dc converter for PV generation system," in Proc. IEEE Int. Symp. Ind. Electron., Jul. 2010, pp. 2205–2210.
- [18] I. Sefa and S. Ozdemir, "Multifunctional interleaved boost converter for PV systems," in Proc. IEEE Int. Symp. Ind. Electron., Jul. 2010, pp. 951–956.