

Independent Operation Of Two Three Phase Loads Using Nine-Switch Inverter

T.Siva balaji¹; B.Shivashankar²; G.SatyaNarayana³

Assistant Professor(EEE)¹; Assistant Professor(EEE)²; Assistant Professor(EEE)³
GNITC¹;VITS²;SITE³

thota.sivabalaji@gmail.com¹; shivshankar228@gmail.com²;
garapati.narayana@gmail.com³

Abstract: This paper proposes space vector modulation for nine switch inverter as dual output inverter. proposed technique compared with carrier based PWM technique and space vector modulation technique (SVM).SVM technique increases the sum modulation indices up to 15% in contrast with conventional scheme, in which the sum of modulation indices is equal or less than one. The extra high voltage available for a given input dc-voltage translates to higher torque. This paper introduces novel SVM technique with minimum semiconductor switching and reduced THD. Min semiconductor switching method reduces the cost of power devices and thermal heat effect, this scheme will be advantages for high power applications. Where as reduce THD method minimize the total harmonic distortion. The performance of proposed SVM for nine switch inverter is verified by simulation.

keywords : Nine –switch inverter , space vector modulation (SVM)

INTRODUCTION

In many cases, there are two or more ac loads, which require independent control. The conventional solution is to use separate inverters. This increases cost and volume of system. A dual output inverter has been presented in [1] using only nine semiconductor switches (see Fig. 1). This inverter is known as nine-switch inverter and is also used as an ac/ac converter in [2] and [3]. The nine-switch inverter is composed of two conventional inverters with three common switches. In nine-switch inverter sum modulation index of two outputs must be less than or equal to one

Therefore, voltage amplitude of outputs is smaller, compared with two separate inverters [4]. This problem can rectify by space vector modulation. In [1], carrier-based pulse width modulation (PWM) methods have been proposed for nine-switch inverter. This paper proposes space vector

modulation (SVM) methods for the aforementioned nine-switch inverter. This paper describes the carrier-based PWM control method for nine-switch inverter, Space Vector modulation (SVM) for nine-switch inverter. This SVM Method includes two special SVMs with minimum semiconductor switching and Reduced THD. These Techniques are verified through simulation

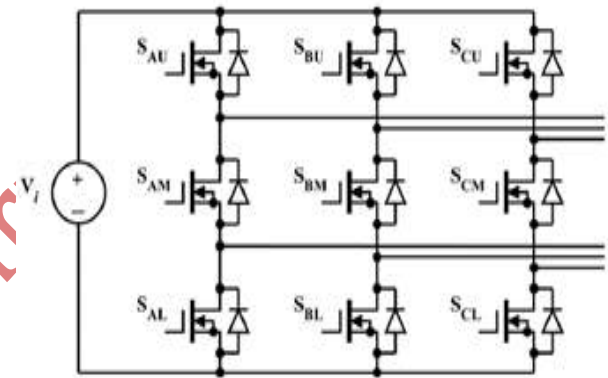

Fig .1. Nine-switch Inverter

The carrier-based PWM control method for nine-switch inverter is shown in Fig. 2. There are two reference signals (upper and lower) for each phase. The upper and lower reference signals are related to upper and lower outputs respectively.

CARRIER BASED PWM METHOD

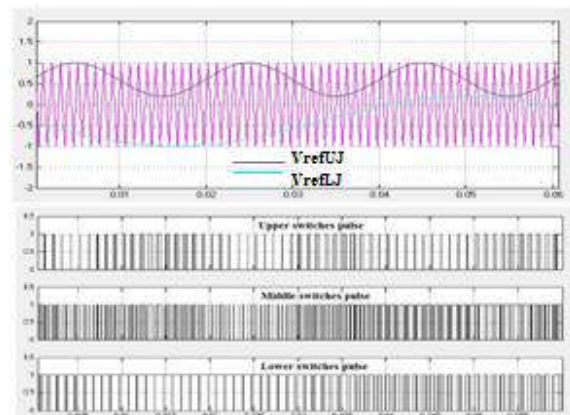

Fig.2. Carrier-based PWM method for nine-switch inverter

The gate signal for upper switch of leg generated by comparing the carrier signal and upper reference signal of the related phase (V_{refUJ}). Similarly, the gate signal for lower switch is generated from the carrier signal and lower reference signal of the related phase (V_{refLJ}). The gate signal for mid switch is generated by the logical XOR of the gate signals for upper and lower switches. With this method, always two switches are ON in each leg. carrier signal and upper reference signal of the related phase (V_{refUJ}). Similarly, the gate signal for lower switch is generated from the carrier signal and lower reference signal of the related phase (V_{refLJ}). The gate signal for mid switch is generated by the logical XOR of the gate signals for upper and lower switches. With this method, always two switches are ON in each leg.

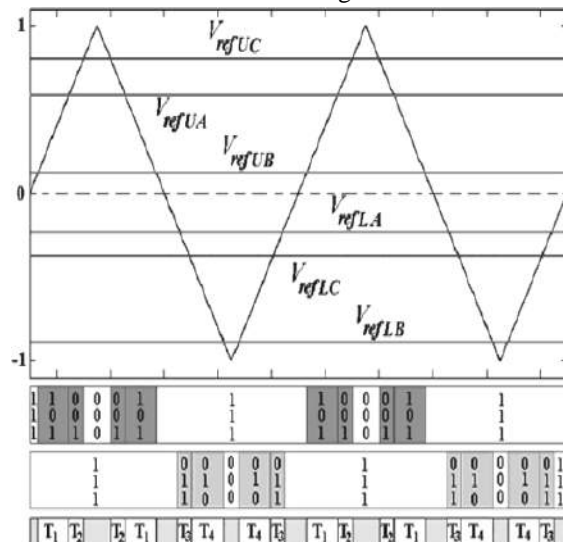

Fig.3. Carrier- based PWM method switching vector

Fig. 3 shows carrier-based PWM method switching vectors. There are six vectors in each switching cycle for both outputs: two nonzero vectors, one zero vector 0 0 0, two none zero vectors and one zero vector 1 1 1 {two active—short zero (0 0 0)—two active—long zero (1 1 1)}. In an active vector, output load is connected to the dc input source, while in a zero vector, the output load is short-circuited.

SVM FOR NINE-SWITCH INVERTER

Each leg can be in three different semiconductors ON-OFF position. These position can be called {1}, {0}, and {2}, as is illustrated in Table I. In Table I, J refers to leg A, B, or C and U, M, L refers to upper, mid, and lower

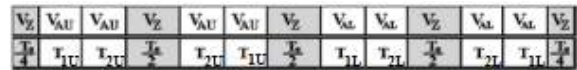

Fig.4 Typical SVM switching vector sequence

**TABLE I
Semiconductors On-Off Position of leg**

	S _{JU}	S _{JL}	S _{JM}
1	ON	OFF	ON
0	OFF	ON	ON
2	ON	ON	OFF

**TABLE II
SVM Switching Vectors**

Vector	Leg A	Leg B	Leg C	Type
1	1	0	0	Upper Active
2	1	1	0	
3	0	1	0	
4	0	1	1	
5	0	0	1	
6	1	0	1	
7	2	1	1	Lower Active
8	2	2	1	
9	1	2	1	
10	1	2	2	
11	1	1	2	
12	2	1	2	
13	1	1	1	Zero
14	0	0	0	
15	2	2	2	

semiconductor, respectively. The combination of switching vector of both outputs in Fig. 3 creates a specific sequence as shown in Fig. 4. This sequence is used to design SVM method. There are 12 vectors in each switching cycle: {two upper active (V_{AU})—zero (V_Z)—two upper active (V_{AU})—zero (V_Z)—two lower active (V_{AL})—zero (V_Z)—two lower active (V_{AL})—zero (V_Z)}. The switching vectors are listed in Table II. The vectors V1–V6 are upper active vectors. In these vectors, the upper output is in active state, and the lower output is in zero state. There is an inverse logic in lower active vectors (V7–V12). In zero vectors (V13–V15), both outputs are in zero state.

Table II does not include all possible variations of switching states {1}, {0}, and {2}. Since a vector including {2} and {0} connects both loads to the dc source at the same time, the loads lose their independence and they cannot have independent frequencies. This is the reason for avoiding a vector that includes combinations of {2} and {0}

To determine the proper active vectors, two space vector diagrams are proposed as shown in Fig.

5. The diagrams (a) and (b) are used to determine the upper and lower active vectors, respectively. The SVM active vectors are determined with regard to location of upper reference signal (\bar{v}_{refU}) in the diagram (a) and lower reference signal (\bar{v}_{refL}) in the diagram (b). The reference signals for the upper and lower outputs are defined as

$$V_{refU} = V_{refU} \angle \alpha_U \quad (1)$$

$$V_{refL} = V_{refL} \angle \alpha_L \quad (2)$$

Where

$$\alpha_U = 2\pi f_U t + \phi_U \quad (3)$$

$$\alpha_L = 2\pi f_L t + \phi_L \quad (4)$$

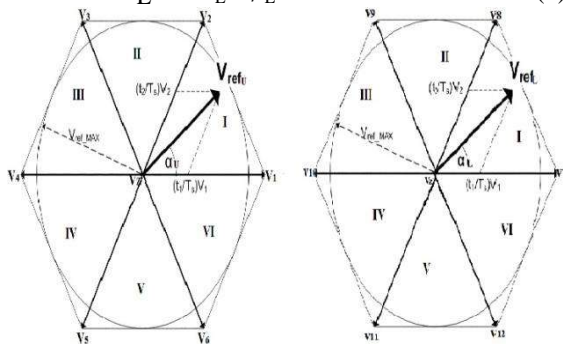

where f_U, f_L are the frequencies, and ϕ_U, ϕ_L are the phases. All zero vectors V_{13}, V_{14} , and V_{15} can be used for zero states. The type of zero vectors can be selected based on control goals and optimizations such as minimum number of semiconductor switching

$$T_{1U} = \frac{\sqrt{3}}{2} m_U T \sin\left(\frac{\pi}{3} - \alpha_U\right) \quad (5)$$

$$T_{2U} = \frac{\sqrt{3}}{2} m_U T \sin(\alpha_U) \quad (6)$$

$$T_{1L} = \frac{\sqrt{3}}{2} m_L T \sin\left(\frac{\pi}{3} - \alpha_L\right) \quad (7)$$

$$T_{2L} = \frac{\sqrt{3}}{2} m_L T \sin(\alpha_L) \quad (8)$$

$$T_0 = T - T_{1U} - T_{2U} - T_{1L} - T_{2L} \quad (9)$$

where T_{1U}, T_{2U} are the time interval of upper active vectors, T_{1L}, T_{2L} are time of lower active vectors, T_0 is time of zero vectors and T is switching period. m_U and m_L are upper and lower modulation indices, respectively, and defined by

$$m_U = 2 \frac{V_{refU}}{V_i} \quad (10)$$

$$m_L = 2 \frac{V_{refL}}{V_i} \quad (11)$$

The sum of active vector time intervals must be less or equals to T . Thus, the following constrain must be satisfied.

$$(T_{1U} + T_{2U} + T_{1L} + T_{2L}) \leq T \quad (12)$$

By substituting the values of T_{1U}, T_{2U}, T_{1L} and T_{2L}

We get sum of modulation Indices as follows

$$(m_U + m_L) \leq \frac{2}{\sqrt{3}} \approx 1.155 \quad (13)$$

Equation (12) clearly indicates that in the proposed SVM scheme, sum of modulation indices increases about 15% a very important feature to provide higher torque for a given input dc-voltage. In the case of washing machines, the above capability translates to higher machine capacity (in terms of cloth load) at high spin speed (e.g., 1800 r/min) an important product feature in marketplace.

A switching vector sequence for the proposed SVM is shown in Fig. 6. This switching sequence is developed to reduce the number of semiconductor switching. The zero vectors are placed just between two upper and lower active vectors. In upper active

V_{refU} in I, III or V						V_{refL} in I, III or V					
V_{13}	V_{AU2}	V_{AU1}	V_{AL3}	V_{AU2}	V_{13}	V_{AL1}	V_{AL2}	V_{AL2}	V_{AL1}	V_{13}	
$\frac{T_0}{2}$	T_{2U}	T_{1U}	T_{1U}	T_{2U}	T_0	T_{1L}	T_{2L}	T_{2L}	T_{1L}	$\frac{T_0}{2}$	
V_{refU} in II, IV or VI						V_{refL} in I, III or V					
V_{13}	V_{AU1}	V_{AU2}	V_{AU2}	V_{AU1}	V_{13}	V_{AL1}	V_{AL2}	V_{AL2}	V_{AL1}	V_{13}	
$\frac{T_0}{2}$	T_{1U}	T_{2U}	T_{2U}	T_{1U}	T_0	T_{1L}	T_{2L}	T_{2L}	T_{1L}	$\frac{T_0}{2}$	
V_{refU} in I, III or V						V_{refL} in II, IV or VI					
V_{13}	V_{AU2}	V_{AU1}	V_{AU1}	V_{AU2}	V_{13}	V_{AL2}	V_{AL1}	V_{AL1}	V_{AL2}	V_{13}	
$\frac{T_0}{2}$	T_{2U}	T_{1U}	T_{1U}	T_{2U}	T_0	T_{2L}	T_{1L}	T_{1L}	T_{2L}	$\frac{T_0}{2}$	
V_{refU} in II, IV or VI						V_{refL} in II, IV or VI					
V_{13}	V_{AU1}	V_{AU2}	V_{AU2}	V_{AU1}	V_{13}	V_{AL2}	V_{AL1}	V_{AL1}	V_{AL2}	V_{13}	
$\frac{T_0}{2}$	T_{1U}	T_{2U}	T_{2U}	T_{1U}	T_0	T_{2L}	T_{1L}	T_{1L}	T_{2L}	$\frac{T_0}{2}$	

Fig.6. SVM with reduced number of semiconductor switching

vectors, legs are in state $\{1\}$ or $\{0\}$ and in lower active vectors, legs are in state $\{1\}$ or $\{-1\}$. If V_{13} zero vector is placed between the active vectors, minimum number of switching is required. While if V_{14} or V_{15} zero vectors are used, number of switching is increased.

There are two odd active vectors ($V_1, V_3, V_5, V_8, V_{10}$, and V_{12}) and two even active vectors (V_2, V_4, V_6, V_7, V_9 , and V_{11}) in a switching sequence. In an even active vector, two legs are in state $\{1\}$, while in an odd active vector only one leg is in state $\{1\}$. If even active vectors are placed next to V_{13} , number of switching will be reduced even more (see Fig. 6).

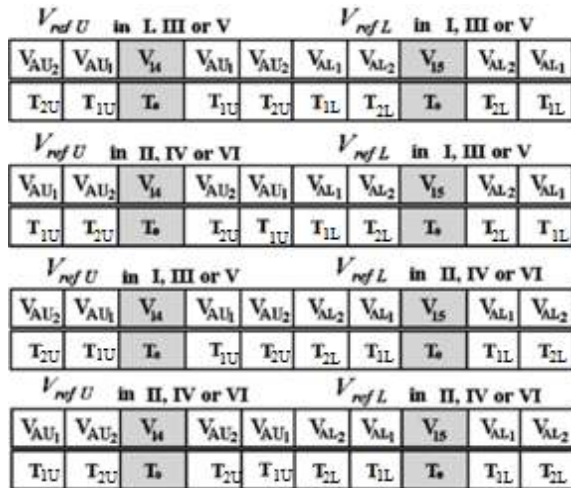

Fig.7. SVM with Reduced THD.

There are other possible switch generation methods too, e.g., a switching method, to reduce THD. To minimize THD, active vectors for each output should be centrally placed within the switching period. Fig. 7 shows a switching vector sequence that shifts active vector into center of switching period, hence reducing THD. In this sequence, zero vectors are inserted between active vectors. In Fig. 7, V14 is inserted between upper active vectors and V15 is inserted between lower active vectors.

SIMULATIONS AND EXPERIMENTAL RESULTS

TABLE III
Simulation Parameters

Parameter	value	
Switching frequency	3kHz	
f_U	25Hz	
f_L	50Hz	
R_{load}	20ohm	
L_f	10mH	
Nine switch inverter	m_U	0.50
	m_L	0.50

The proposed SVM are simulated for nine-switch inverter. Two Similar RL loads are connected to the outputs of inverter. Simulation parameters are listed in Table III. Number of switching of semiconductors for nine-switch inverter and z-source-nine-switch inverter using carrier-based PWM and the proposed SVMs are shown in Table IV. Number of switching for 0.1 s with parameters of Table III is calculated

TABLE IV
Number Of Semiconductor Switching

	SPWM	SVM(Minimum switching)	SVM(Minimum THD)
Nine-switch inverter	3500	2450	3400

The nine-switch inverter with input dc source of 415 V is simulated and implemented with reduced number of switching SVM. Figs. 8 and 9 show line–line voltage and phase voltage of both outputs, respectively

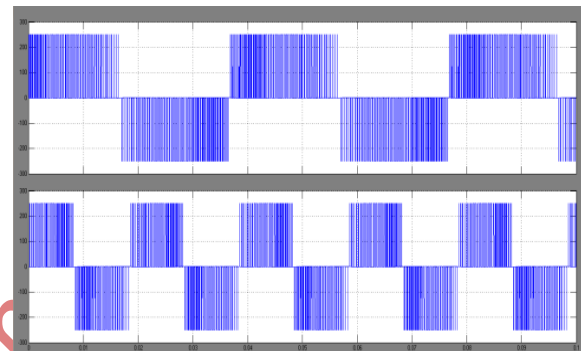

Fig. 8 Line voltage of Nine-switch inverter ,(100 V/DIV, 10ms/DIV).

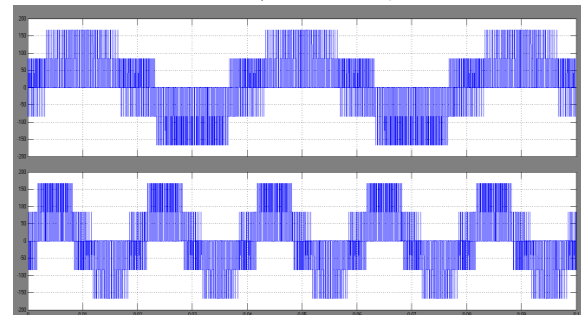

Fig.9. Phase voltage of Nine-switch inverter (min switching SVM), (100 V/DIV, 10ms/DIV).

It can be seen that both outputs have expected frequencies. The load current is shown in Fig. 10. It can be seen that the load currents have nearly sinusoidal waveforms.

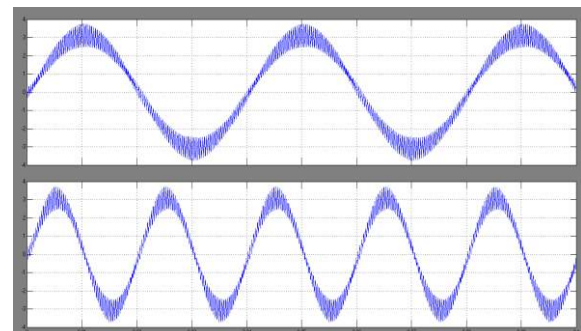

Fig.10.Output currents of Nine-switch inverter (min switching SVM). (10A/DIV, 10 ms/DIV)

Fig. 11 shows THD of load current versus load current magnitude for different cases: a) carrier-based PWM, b) reduced THD SVM and c) minimum semiconductor switching SVM

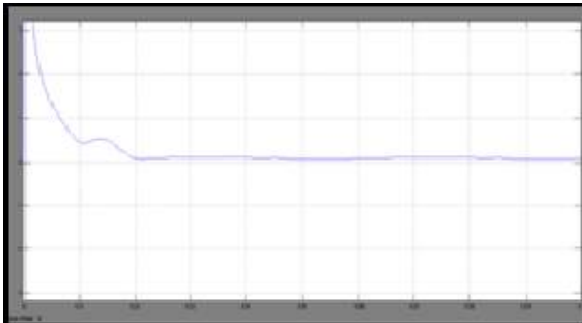

Fig .11(a). Carrier –based PWM method

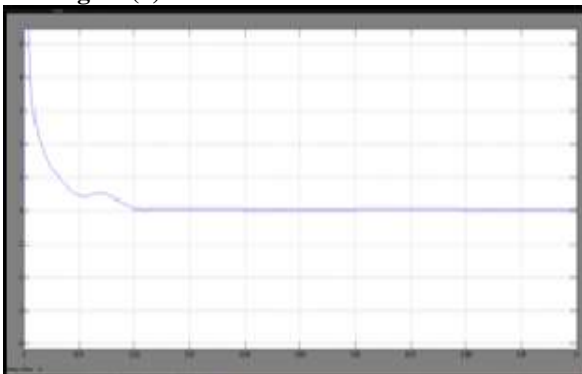

Fig .11(b). Reduced THD SVM method



Fig.11(c) .Minimum semiconductor switching SVM

From the above simulation results THD for carrier –based PWM method is 7.6% ,for minimum semiconductor switching SVM method is 5.6% and for reduced THD SVM method THD in load current is 4.7%.

CONCLUSION

In this paper, the SVM of nine-switch inverter was proposed , Switching sequence of the proposed SVM is composed of the upper active vectors, the lower active vectors and the zero vectors. The upper and lower active vectors are determined via two

space vector diagram. The proposed SVM increases sum of modulation indices up to 15%, an important feature in providing higher torque for a given input dc-voltage. The proposed SVMs were simulated for the nine-switch inverter, The performance of the proposed SVMs was verified using computer simulation.

The proposed SVM has to developed for nine switch- z-source inverter via extra shoot-through vectors

REFERENCES

- [1] T. Kominami and Y. Fujimoto, "A novel nine-switch inverter for independent control of two three-phase loads," in *Proc. IEEE Ind. Appl. Soc. Annu. Conf. (IAS)*, 2007, pp. 2346–2350.
- [2] C. Liu, B. Wu, N. Zargari, and D. Xu, "A novel three-phase three-leg AC/AC converter using nine IGBTs," *IEEE Trans. Power Electron.*, vol. 24, no. 5, pp. 1151–1160, May 2009.
- [3] C. Liu, B.Wu, N. Zargari, and D.Xu, "A novel nine-switch PWM rectifier inverter topology for three-phase UPS applications," *J. Eur. Power Electron. (EPE)*, vol. 19, no. 2, pp. 1–10, 2009.
- [4] K. Oka, Y. Nozawa, R. Omata, K. Suzuki, A. Furuya, and K. Matsuse, "Characteristic comparison between five-leg inverter and nine-switch inverter," in *Proc. Power Convers. Conf., Nagoya*, 2007, pp. 279–283