

# A Comparative study for MPPT in Solar PV system under Partial Shading condition using P&O and GA

**Authors: Mr. Sunil Kumar Gour<sup>1</sup>, Mr. Pawan Pandey<sup>2</sup> Ms. Minal Tomar<sup>3</sup>**

<sup>1</sup> M. Tech Scholar in Power Electronics, MIT, Indore (M.P). E-mail: (sunil13gour@gmail.com)

<sup>2</sup>Assistant Professor & head in Electrical & Electronics Dept. MIT, Indore (M.P). E-mail: (pawanpandey@mitindore.co.in)

<sup>3</sup>Assistant Professor Electrical & Electronics Dept. MIT, Indore (M.P). E-mail: (minaltomar@mitindore.co.in)

**Abstract:** The decreasing cost of photovoltaic (PV) panels and the availability of power electronic converters have led to a worldwide growth in isolated and interconnected power systems for reliable power utilization. To extract the maximum power from solar PV, maximum power point tracking (MPPT) controllers are needed to operate the PV arrays at their maximum power point under varying environmental conditions. Generally, partial shading is classified as either aperiodic or periodic shades. The former is mostly due to clouds, whereas the latter are mainly due to poles, buildings, trees, and towers, places where the shade occurs daily and in a regular manner. This work presents a novel MPPT (maximum power point tracking) algorithm, based on a GA (genetic algorithm) and conventional P&O technique. When photovoltaic systems are affected by partial shading, a global maximum power point tracking algorithm is required to increase the energy harvesting capability of the system.

The results demonstrate that the proposed algorithm outperforms conventional techniques in case of partial shading detection problem. The proposed method is guaranteed to find periodic shade and the global maximum operating point, avoiding the local operating point obstacle. Using MATLAB, the algorithm is implemented and tested in a simulation model.

**Keywords:** Partial Shading Condition, MPPT, Solar PV, P&O, Genetic Algorithm, Matlab, Renewable energy.

## 1. Overview

The increasing power demand in the industry and domestic sector leads to the utilization of renewable energy sources. The disadvantage of non-renewable

energy sources is exhaustible and also producing pollution. Photovoltaic energy, among the various renewable energy sources has many advantages (like it is) such as pollution free, easy to maintain, absence of gas emission and no fuel cost. The drawback of PV system is low efficiency due to change in environmental conditions like irradiation, temperature. Partial shading is also due to shadows of trees, buildings and towers, passing clouds and dust. Under Partial Shading Condition (PSC), PV array exhibits local and global power peaks. Tracking global power peak is the main challenge under partial shading condition. Optimization techniques are used to overcome these issues and to track the global power peak by determining the best duty value for the boost converter to extract maximum power from PV array under partial shading condition.

## 2. Literature review

As the world shifts towards renewable sources of energy, solar power has emerged as a promising solution to meet the growing demand for electricity. However, one of the most significant challenges faced by solar photovoltaic (PV) systems is partial shading. When solar panels are partially shaded, the energy output is significantly reduced, leading to a decrease in power efficiency. To combat this issue, Maximum Power Point Tracking (MPPT) has emerged as a popular solution in the industry. This literature review will delve into the various MPPT techniques that have been developed to enhance the efficiency of solar PV systems in partially shaded environments. We will examine the strengths and weaknesses of each technique, and how they can be applied to maximize the output of solar PV systems. By the end of this review, readers will have a deeper understanding of the importance of MPPT for partially shaded solar PV systems, and how it can help illuminate the shadows.

**Sabrina Titri et. al. [1]** The Maximum Power Point Tracking controller (MPPT) is a key element in

Photovoltaic systems (PV). It is used to maintain the PV operating point at its maximum under different temperatures and sunlight irradiations. The goal of a MPPT controller is to satisfy the following performances criteria: accuracy, precision, speed, robustness and handling the partial shading problem when climatic changes variations occur. To achieve this goal, several techniques have been proposed ranging from conventional methods to artificial intelligence and bio- inspired methods.

**Loubna Bouselham et. al. [2]** In solar photovoltaic system, tracking the maximum power point (MPP) is challenging task due to varying climatic conditions. Moreover, the tracking algorithm becomes more complicated under the condition of partial shading due to the presence of multiple peaks in the power voltage characteristics. This paper introduces a novel method to track the global maximum power point under partially shaded conditions. The method combines an artificial neural network controller with a scanning algorithm.

**Dimas Aji Nugraha et. al. [3]** Partial shading is a common and difficult problem to be solved in a photovoltaic (PV) system. Numerous efforts have been introduced to mitigate this problem. Some commonly used approaches are deploying some metaheuristic (MH) algorithm to track the multiple-peak P-V curve of partially shaded PV system.

Cuckoo search (CS) is a new optimization algorithm based on the MH approach. It has been used to solve an optimization problem in many applications, including the maximum power point tracking (MPPT) problem..

**Hegazy Rezk et. al. [4]** A novel statistical performance evaluation of most modern optimization-based global MPPT techniques for partially shaded PV system is presented in this paper. In recent years, there has been a growing attention toward mitigation of partial shading effect of the PV system through using modern optimization. The field of tracking MPP of the PV system attracts huge attention from the researchers, as it is the best way to increase PV plant efficiency.

**Emad M. Ahmed et al. [5]** in 2019 discussed that the integration of photovoltaic (PV) systems with three-phase four-wire (3P4W) distribution networks has imposed several challenges related to existing unbalanced loads, reactive power generation and harmonics content. In this paper, a multifunctional distributed maximum power point (MPPT) controller for grid integration of PV systems is proposed.

**K. Ding, X. Bian, H. Liu, T. Peng [6]** in 2019 discussed that the performance of a photovoltaic

(PV) module is mostly affected by array configuration, irradiance, and module temperature. It is important to understand the relationship between these effects and the output power of the PV array.

**Rozana Alik, Awang Jusoh [7]** in 2018 presents the impact of partial shading to the PV system and proposes an enhanced Perturb and Observe (P&O) algorithm with a checking algorithm. This checking algorithm compared all existed peaks on the PV curve to clarify the global maximum power point (GMPP). The boost converter duty cycle is calculated using voltage at MPP (VMPP), identified through a variable step size P&O algorithm.

**Neeraj Priyadarshi [8]** in 2018 discussed the experimental realization of grid-connected photovoltaic (PV) system using dSPACE DS 1104 control board. To obtain high tracking efficiency, an adaptive Neuro-Fuzzy inference system (ANFIS)-based maximum power point tracking (MPPT) algorithm is proposed. The performance of the system is improved by fuzzy logic control (FLC), which generates the switching signal to the power switches of inverter.

**Alivarani Mohapatra et. al. [9]** in 2017 discussed that a concise and an organized review of various maximum power point tracking (MPPT) algorithms implemented in the photovoltaic (PV) generation system useable under partial shading condition. Various algorithms, PV modeling techniques, PV array configurations and controller topologies have been widely explored till date.

**R. Benkercha S. Moulahoum I. Colak [10]** in 2017 discussed that the Grid Connected Photovoltaic System (GCPV) has become more used system in renewable energy. Several researches have been carried out to improve the efficiency and the decrease of energy losses. One of the important components used to increase the efficiency is the DC/DC boost converter.

### 3. PHOTO VOLTAIC (PV) SYSTEM

In this chapter the modeling and design of overall system such as PV system, boost converter, load and MPPT controller has been presented.

#### i. Photovoltaic Cell

Photoelectric cell is the semiconductor system that changes light to electrical power by photovoltaic. If energy (power) of photon of brightness is superior than the band gap, then an electron of the system is emitted also flow of an electron of system forms current. But the photovoltaic cell is different type of photo diode, when the light of sun falls down on

device of cell is converted. Voltage or current by photo effect however this cell is always forward biased. Translation of photo - voltaic energy to electrical and thermal power of system have been use for many years. To conversion the PV power to electrical, photo voltaic are used. Photovoltaic modules make use of the photoelectric effect in order to directly perform the above conversion. Solar panels convert solar radiation to electricity with efficiencies in the vary of 5% to 20%, of system depend on form of the photovoltaic cell. Polycrystalline silicon PV cells offer the highest range of possibilities for applications. For consequence of their modest price relative to the mono crystalline silicon cells, and their considerable stability and efficiency (about 15%). Furthermore, these cells are sold in type of panels having dark blue appearance which is esthetically pleasant. When the temperature of a so PV module is increased, the efficiency drops. This can usually result in an efficiency drop off of 0.5% per °C progress in the cell operating temperature.

**ii Equivalent circuit and Mathematical Model**

A current source type PV model is discussed in this section. The equivalent circuit is also shown.

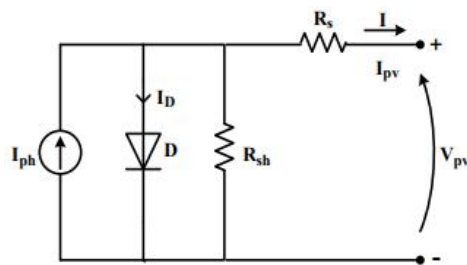

Fig. 1: The equivalent circuit of a PV array.

Where,  $R_s$  is the array series resistance in Ohm,  $R_p$  is the array parallel resistance in Ohm,  $I$  and  $V$  are the output current and voltage of the array in Ampere and Volt.

$$I = N_p \times I_{ph} - N_s \times I_{rs} \left[ e^{\left( \frac{q \times V}{A \times K \times T} \right) - 1} - \left( \frac{V + I \times R_s}{R_{sh}} \right) \right] \quad (1)$$

Where,  $I_{ph}$  is photo current in Amp,  $I_{rs}$  is saturation current in Amp,  $N_s$  and  $N_p$  are the number of series and parallel modules respectively,  $q$  is charge on electron in coulomb,  $A$  is diode ideality factor,  $T$  is cell Temperature with change in irradiation in degree kelvin.

Now,

$$I_{ph} = I_{scr} + K_i \times (T - T_r) \times S \quad (2)$$

$$I_{rs} = I_{rr} \times \left( \frac{T}{T_r} \right)^3 \times e^{\left( \frac{q \times E_g}{K \times A} \times \left( \frac{1}{T_r} - \frac{1}{T} \right) \right)} \quad (3)$$

Where,  $I_{scr}$  is Short circuit current at reference Temperature in Amp,

$I_{rr}$  is reverse saturation current in Amp,

$T_r$  is reference temperature in Kelvin,

$S$  is solar irradiance in mW/Sq. cm,

$K_i$  is S.C. current Temp. coefficient in (Amp/Kelvin),

$K$  is Boltzmann's constant,

$E_g$  is band gap energy of semiconductor used cell in joules, also,

$$E_g = E_{g0} - \left( \frac{\alpha \times T^2}{T + \beta} \right) \times q \quad (4)$$

Where,  $E_{g0}$  = band gap at 0k and,

$$V_{oc} = \left( \frac{A \times K \times T}{q} \right) \times \ln \left( \frac{I_{ph}}{I_{rs}} \right) \quad (5)$$

**4. An Overview for Maximum Power Point Tracking**

Due to miss-match between power generated by Solar PV system and load connected, the efficiency of system is very poor. Certain methods needed to incorporate with system to increase efficiency. Such type of methodology of improving/maximizing power generation of PV system is known as Maximum power Point Tracking. Since, the V-I characteristic of Solar PV system is non-linear by nature, in order to make it utilizable for load, boost converters are used along with panel. The synchronization between load and generation can be done by modifying duty cycle of this converter using MPP.

In order to plan the control system, the configuration of PV system is to be understand first. Different configuration of PV systems is possible like the most basic one comprised of PV systems suppling power directly to inverter which is further connected to grid. Another type of connection is possible in which instead of suppling whole amount of power to grid, a part is kept to be stored in battery bank storage. A third type of configuration is also possible in which full generated power is stored in battery bank. The advantage of such system is that we don't need to connect each panel with a separate inverter instead we can have a centralized connection of single micro inverter for all increasing efficiency by 20 %.

The MPPT systems are connected to those conversion devices of system which have the ability to modulate current or voltage of supply generated by PV panel. This power electronic based device has the responsibility to convert supply in the form

according to load demand. As discussed earlier the MPPT section is performed with converter section. The point where MPP occurs have a certain value of current and voltage termed as  $I_{mpp}$  and  $V_{mpp}$ . The product this two will eventually give value of maximum power.

#### 4.1 perturb and observe (P&O) algorithm

The perturb and observe (P&O) algorithm is based on the observation of the array output power and the perturbation (increment or decrement) of the power based on increments of the array voltage or current, as the name implies. The algorithm constantly increases or decreases the reference current or voltage based on the previous power sample value. The P&O technique is the simplest way for sensing the PV array voltage, and the cost of implementation is low, making it simple to implement. This method has a low time complexity, but as it gets close to the MPP, it does not step at the MPP and continues to perturb in both directions. The Perturb and Observe algorithm is shown in Figure 4.1.

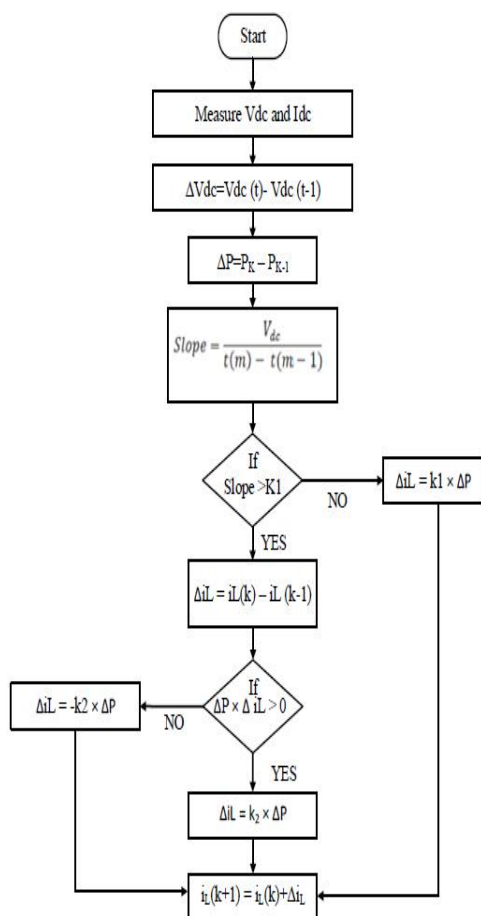

Fig 4.1 Perturb and Observe algorithm.

The Perturb and Observe algorithm is given below.

- Step 1:** Measure the dc link voltage and current
- Step 2:** Calculate the change in dc link voltage and power
- Step 3:** Check the slope of the dc link voltage is greater than a constant  $k_1$
- Step 4:** if  $dV_{dc}/dt > k_1$ , then calculate  $\Delta i_L$  using  $\Delta P$
- Step 5:** if  $dV_{dc}/dt < k_1$ , then calculate  $\Delta i_L$  using the current values of the last two intervals
- Step 6:** Check  $\Delta P \times \Delta i_L > 0$ , then adjust  $\Delta i_L$  in positive direction
- Step 7:** if  $\Delta P \times \Delta i_L < 0$ , then adjust  $\Delta i_L$  innegative direction
- Step 8:** Goto step 1

The change in current is used to adjust the duty cycle of the converter used in the wind energy conversion system.

#### 4.2 Genetic Algorithm

Genetic Algorithm was envisaged by John Holland [67] at the university of Michigan, in the 1970s. It is based on the Darwinian evolution theory of survival of the fittest which states that the fitter and stronger individuals in a population have a higher chance of creating offspring for the next generation by random mutation and natural selection. It can be implemented as an optimization search procedure which uses the principles of genetics and natural selection by modelling possible solutions to a search problem as strings of zeroes and ones. Each point in a parameter or solution space can be encoded by Genetic algorithm (GA) in a binary bit string, which is called the chromosome. For example, if a particular point (8, 5, 7) in a three-dimensional space, is to be transformed, it can be represented by a concatenated binary string of 1000, 0101, 0111. Here each coordinate is encoded by a gene which is represented by four binary bits. Encoding plays a key role in determining the GA's performance as it helps to translate problem specific knowledge directly to the GA framework. After the creation of a generation comprising of these points, each of these points is also assigned a fitness value which is given by the evaluated value of the objective function at that point. Generally positive values of the objective function are preferred.

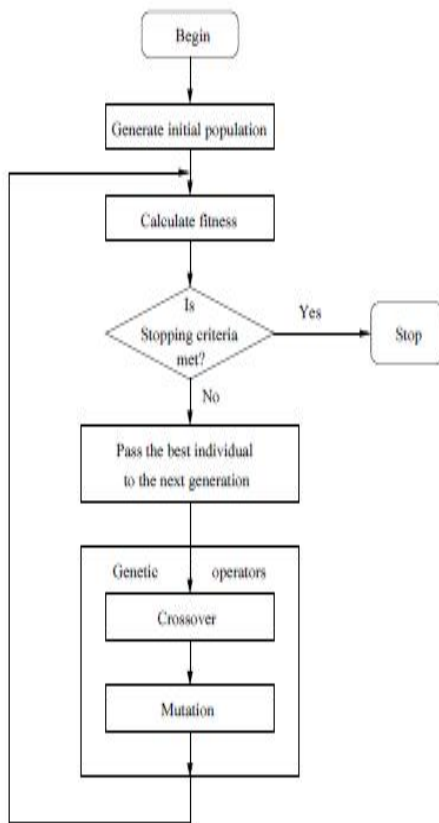

Figure 3: GA algorithm flowchart

**5. Result and Discussion**

In this section, simulation model of PSC-PV system designed for P&O MPPT on MATLAB/Simulink is shown and discussed. The reason to vary the value of irradiation is to create an effect of cloud, which hinder the sunlight falling directly on PV array. The irradiation level varies in following pattern as 1000 225 1000 W/m<sup>2</sup>. This variation in irradiation leads to change in output of PV array. The variation in irradiation moves MPPT to a new point, which need to be traced. This simulation considers both steady state and dynamic state response of the system for sudden change in solar irradiation. In order to obtain suitable voltage, a set of 66 strings connected in parallel, with each string comprised of 5 modules is used. On simulating this model connection along with control system for MPPT with the help of P&O MPPT techniques, effect on various parameters like output power, voltage and current were monitored.

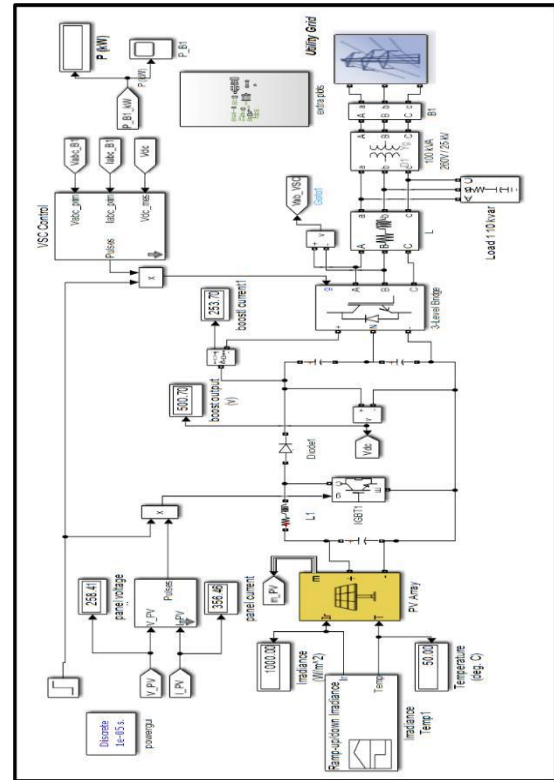

Figure 4: Simulation model of system with IP&O MPPT method

On simulating the model, it is observed that there are certain transients are generated in the system at the starting of simulation while converter is drawing system to MPP. The results were summarized and compared in table 1.

Table 1: Output Parameters with P&O MPPT Method

S.No.	Parameters	P&O Method
1.	Panel Voltage V <sub>pv</sub> (V)	258.41
2.	Panel Current I <sub>pv</sub> (A)	256.46
3.	Irradiation (W/m <sup>2</sup> )	1000
4.	Temperature (0C)	50
5.	PV Maximum Power/MPPT (KW)	91.60
6.	Boost Converter Output Voltage (V)	500.70
7.	Boost Converter Output current (A)	253.70

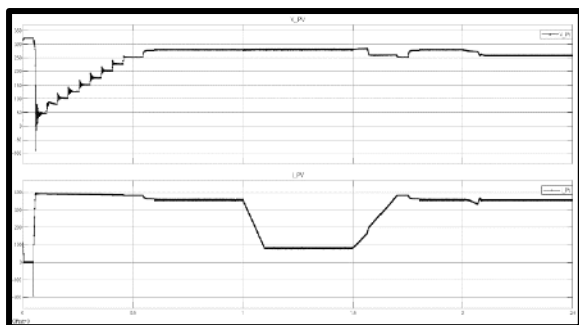

Figure 5: PV array voltage and current with P&O Method

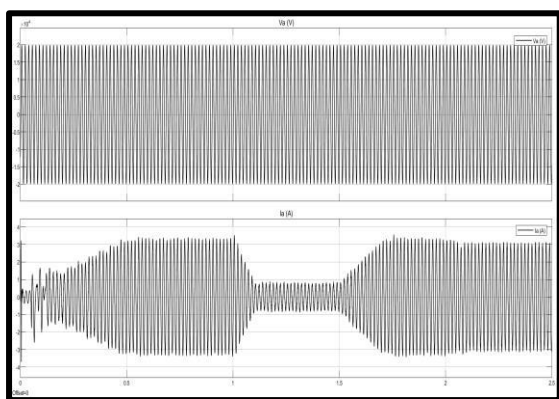

Figure 6: Utility grid voltage and current for P&O MPPT method

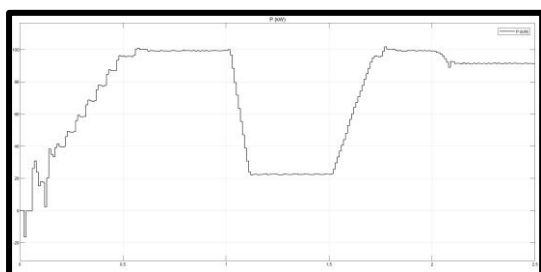

Figure 7: PV array maximum power with P&O Method

### Simulation Modeling and Result Analysis of GA-MPPT Method

In this section, simulation model of PV system designed for GA MPPT on MATLAB/Simulink is shown and discussed. The reason to vary the value of irradiance is to create an effect of cloud, which hinder the sunlight falling directly on PV array. The variation in irradiance moves MPPT to a new point, which need to be traced. This simulation considers both steady state and dynamic state response of the system for sudden change in solar irradiance. On simulating this model connection along with control system for MPPT with the help of GA MPPT

techniques, effect on various parameters like output power, voltage and current were monitored.

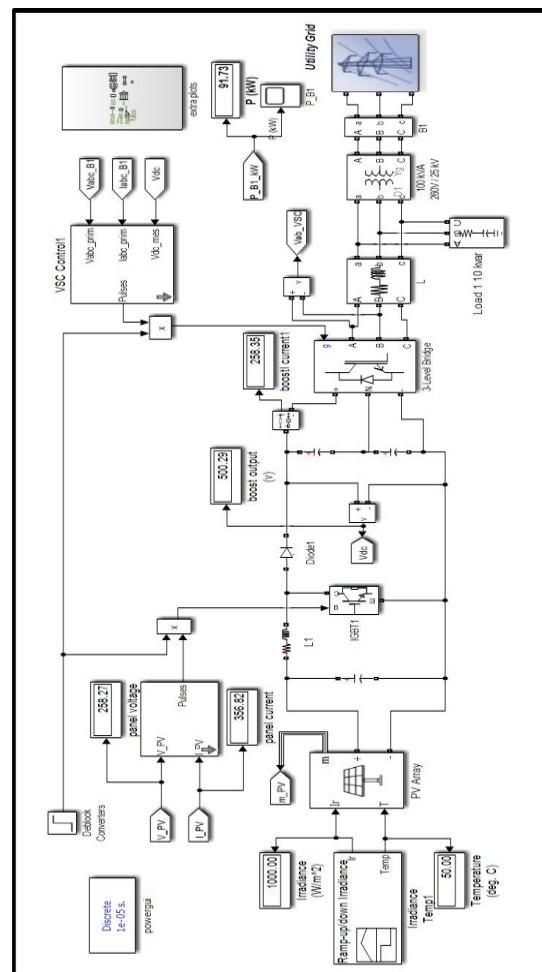

Figure 8: Simulation model of system with GA MPPT method

On simulating the model, it is observed that there are certain transients are generated in the system at the starting of simulation while converter is drawing system to MPP. The results were summarized and compared in table 2.

Table 2: Output Parameters with GA MPPT Method

S. No.	Parameters	GA Method
1.	Panel Voltage Vpv (V)	251.81
2.	Panel Current Ipv (A)	268.91
3.	Irradiance (W/m <sup>2</sup> )	2000
4.	Temperature (0C)	50
5.	PV Maximum Power/MPPT (KW)	92.26
6.	Boost Converter Output Voltage (V)	502.13
7.	Boost Converter Output current (A)	260.82

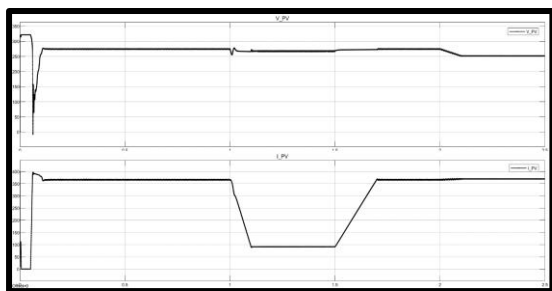

Figure 9: PV array voltage and current with GA Method

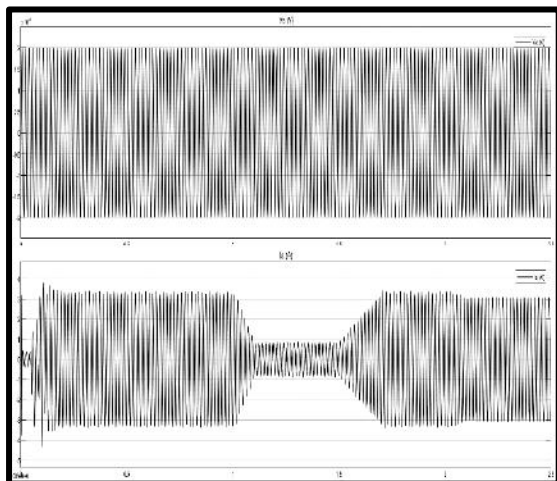

Figure 10: Utility grid voltage and current for GA MPPT method

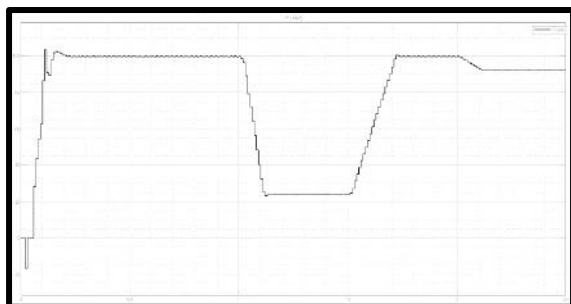

Figure 11: PV array maximum power with GA Method

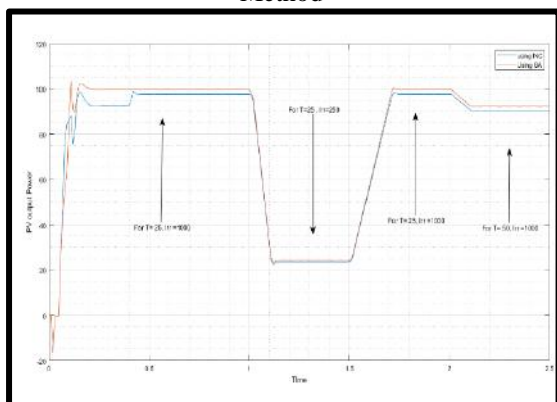

Figure 12: Comparison of PV array maximum power with GA Method

In this section, results were evaluated from both P&O and GA methods for both cases under

consideration and values and plot were displayed through various figures and tables. Values were calculated at both panel end and Boost converter end.

## 6. Conclusion

In this work PV model has been successfully designed and simulated on MATLAB/Simulink software. For realizing net output power generation of this PV system, 2 methods have been proposed for balancing. These methods are GA and P&O.

When PV irradiation and temperature are kept varying, the boost converter output voltage generated by applying both separately is found to be 500.70 V & 501.50 V. In addition, the o/p power using these two methods for constant irradiation are found to be 92.26 KW and 91.60 KW respectively. The result clearly shows that GA method is superior in comparison with P&O for constant irradiation.

The study is performed with variable irradiation and temperature. On simulation, the results obtained are found to give boost converted output voltage of 502.13 V for GA MPPT method and 508.50 V for P&O MPPT method. In addition, the output power of boost converter for variable irradiation is found out to be 92.26 KW for GA and 91.60 KW for P&O respective only comparison results, GA has clear upper hand over P&O method in terms of performance.

## References

- [1] S. Titri, C. Larbes, K. Y. Toumi, and K. Benatchba, "A new MPPT controller based on the Ant colony optimization algorithm for Photovoltaic systems under partial shading conditions," *Applied Soft Computing*, vol. 58, pp. 465–479, Sep. 2017, doi: 10.1016/j.asoc.2017.05.017.
- [2] L. Bouselham, M. Hajji, B. Hajji, and H. Bouali, "A New MPPT-based ANN for Photovoltaic System under Partial Shading Conditions," *Energy Procedia*, vol. 111, pp. 924–933, Mar. 2017, doi: 10.1016/j.egypro.2017.03.255.
- [3] D. A. Nugraha, K. L. Lian, and Suwarno, "A Novel MPPT Method Based on Cuckoo Search Algorithm and Golden Section Search Algorithm for Partially Shaded PV System," *Canadian Journal of Electrical and Computer Engineering*, vol. 42, no. 3, pp. 173–182, 2019, doi: 10.1109/CJECE.2019.2914723.

- [4] H. Rezk *et al.*, "A novel statistical performance evaluation of most modern optimization-based global MPPT techniques for partially shaded PV system," *Renewable and Sustainable Energy Reviews*, vol. 115, p. 109372, Nov. 2019, doi: 10.1016/j.rser.2019.109372.
- [5] E. M. Ahmed, M. Aly, A. Elmelegi, A. G. Alharbi, and Z. M. Ali, "Multifunctional Distributed MPPT Controller for 3P4W Grid-Connected PV Systems in Distribution Network with Unbalanced Loads," *Energies*, vol. 12, no. 24, Art. no. 24, Jan. 2019, doi: 10.3390/en12244799.
- [6] K. Ding, X. Bian, H. Liu, and T. Peng, "A MATLAB-Simulink-Based PV Module Model and Its Application Under Conditions of Nonuniform Irradiance," *IEEE Transactions on Energy Conversion*, vol. 27, no. 4, pp. 864–872, Dec. 2012, doi: 10.1109/TEC.2012.2216529.
- [7] R. Alik and A. Jusoh, "An enhanced P&O checking algorithm MPPT for high tracking efficiency of partially shaded PV module," *Solar Energy*, vol. 163, pp. 570–580, Mar. 2018, doi: 10.1016/j.solener.2017.12.050.
- [8] N. Priyadarshi, A. K. Sharma, and S. Priyam, "An Experimental Realization of Grid-Connected PV System with MPPT Using dSPACE DS 1104 Control Board," in *Advances in Smart Grid and Renewable Energy*, Singapore, 2018, pp. 125–133, doi: 10.1007/978-981-10-4286-7\_13.
- [9] A. Mohapatra, B. Nayak, P. Das, and K. B. Mohanty, "A review on MPPT techniques of PV system under partial shading condition," *Renewable and Sustainable Energy Reviews*, vol. 80, pp. 854–867, Dec. 2017, doi: 10.1016/j.rser.2017.05.083.
- [10] R. Benkercha, S. Moulahoum, and I. Colak, "Modelling of Fuzzy Logic Controller of a Maximum Power Point Tracker Based on Artificial Neural Network," in *2017 16th IEEE International Conference on Machine Learning and Applications (ICMLA)*, Dec. 2017, pp. 485–492, doi: 10.1109/ICMLA.2017.0-114.
- [11] V. R. Kota and M. N. Bhukya, "A novel linear tangents-based P&O scheme for MPPT of a PV system," *Renewable and Sustainable Energy Reviews*, vol. 71, pp. 257–267, May 2017, doi: 10.1016/j.rser.2016.12.054.
- [12] S. Titri, C. Larbes, K. Y. Toumi, and K. Benatchba, "A new MPPT controller based on the Ant colony optimization algorithm for Photovoltaic systems under partial shading conditions," *Applied Soft Computing*, vol. 58, pp. 465–479, Sep. 2017, doi: 10.1016/j.asoc.2017.05.017.
- [13] K. Ranjan and N. Kumar, "Modelling and simulation of Perturb and Observe algorithm on solar PV system using different converters in MATLAB/SIMULINK," in *2016 IEEE 1st International Conference on Power Electronics, Intelligent Control and Energy Systems (ICPEICES)*, Jul. 2016, pp. 1–6, doi: 10.1109/ICPEICES.2016.7853373.
- [14] V. K. Viswambaran, A. Ghani, and E. Zhou, "Modelling and simulation of maximum power point tracking algorithms review of MPPT techniques for PV applications," in *2016 5th International Conference on Electronic Devices, Systems and Applications (ICEDSA)*, Dec. 2016, pp. 1–4, doi: 10.1109/ICEDSA.2016.7818506.
- [15] H. Patel, M. Gupta, and A. K. Bohre, "Mathematical modeling and performance analysis of MPPT based solar PV system," in *2016 International Conference on Electrical Power and Energy Systems (ICEPES)*, Dec. 2016, pp. 157–162, doi: 10.1109/ICEPES.2016.7915923.
- [16] C. Li, Y. Chen, D. Zhou, J. Liu, and J. Zeng, "A High-Performance Adaptive Incremental Conductance MPPT Algorithm for Photovoltaic Systems," *Energies*, vol. 9, no. 4, p. 288, Apr. 2016, doi: 10.3390/en9040288.
- [17] M. Kermadi and E. M. Berkouk, "A maximum power point tracker based on particle swarm optimization for PV-battery energy system under partial shading conditions," in *2015 3rd International Conference on Control, Engineering Information Technology (CEIT)*, May 2015, pp. 1–6, doi: 10.1109/CEIT.2015.7233061.
- [18] K. Visweswara, "An Investigation of Incremental Conductance based Maximum Power Point Tracking for Photovoltaic System," *Energy Procedia*, vol. 54, pp. 11–20, Jan. 2014, doi: 10.1016/j.egypro.2014.07.245.
- [19] R. Garg, A. Singh, and S. Gupta, "PV cell models and dynamic simulation of MPPT trackers in MATLAB," in *2014 International Conference on Computing for Sustainable Global Development (INDIACom)*, Mar. 2014, pp. 6–12, doi: 10.1109/IndiaCom.2014.6828003.
- [20] T. Logeswaran and A. SenthilKumar, "A Review of Maximum Power Point Tracking Algorithms for Photovoltaic Systems under Uniform and Non-uniform Irradiances," *Energy Procedia*, vol. 54, pp. 228–235, Jan. 2014, doi: 10.1016/j.egypro.2014.07.266.
- [21] B. Subudhi and R. Pradhan, "A Comparative Study on Maximum Power Point Tracking Techniques for Photovoltaic Power

Systems,” *IEEE Transactions on Sustainable Energy*, vol. 4, no. 1, pp. 89–98, Jan. 2013, doi: 10.1109/TSTE.2012.2202294.

[22] D. Beriber and A. Talha, “MPPT techniques for PV systems,” in *4th International Conference on Power Engineering, Energy and Electrical Drives*, May 2013, pp. 1437–1442, doi: 10.1109/PowerEng.2013.6635826.

[23] A. Safari and S. Mekhilef, “Incremental conductance MPPT method for PV systems,” in *2011 24th Canadian Conference on Electrical and Computer Engineering (CCECE)*, May 2011, pp.

000345–000347,

doi: 10.1109/CCECE.2011.6030470.

doi:

[24] V. Phimmasone, T. Endo, Y. Kondo, and M. Miyatake, “Improvement of the Maximum Power Point Tracker for photovoltaic generators with Particle Swarm Optimization technique by adding repulsive force among agents,” in *2009 International Conference on Electrical Machines and Systems*, Nov. 2009, pp. 1–6,

doi: 10.1109/ICEMS.2009.5382713.