

A PI and Fuzzy Logic Based Speed Controller for Three-Phase Induction Motor

Authors: Ms. Mahima Paliwal¹, Mr. Pawan Pandey²

¹ M. Tech Scholar in Power Electronics, MIT, Indore (M.P). E-mail: (paliwalmahima@gmail.com)

²Assistant Professor & head in Electrical & Electronics Dept. MIT, Indore (M.P). E-mail: (pawanpandey@mitindore.co.in)

Abstract Every manufacturing Industry which drives heavy load requires help of three phase induction motor to run its mechanical load. The reason behind its popularity is its low manufacturing cost, less maintenance and simple working Mr. Mahima Paliwal¹, Mr. Pawan Pandey² principle. Induction motors also widely find prime application in many commercial, residential and agricultural centers. Initially in all-purpose having constant load uses IM and varying load is done using DC motor due to its smooth speed control characteristics. But in past couple of decades many scalars and vector control strategies has been developed for Induction Motor drives thus replacing DC drives completely. In almost all industries a varying mechanical load is needed to be fulfilled with varying torque produced by Induction Motor speed control.

Hence it is expected from induction motor drives to have high grade efficient performance. From efficient performance a smooth speed control of motor is expected which will eventually lead to the conservation of energy.

This work is mainly focused in utilizing the power of artificial neural network in speed control of 3 ϕ IM. A comparison of result obtained through this method is done with the conventional technique to prove the superiority of the artificial intelligence in solving this problem. The designing of induction motor drive based on ANN is consisting of two parts, one is an identifier based on ANN which has the purpose of estimating required motor speed and the other is controller based on ANN which has a purpose of forming an appropriate signal for the motor speed controlling. For both such purposes, usually backpropagation neural network training approach is very affective due to its exceptional quality to drive meaning out of non-linear distributed data. The

proposed work is done using MATLAB/Simulink software.

Keywords: *Induction Motor Drives, Self-Tuning Controller, Speed Control, Fuzzy logic controller (FLC), Proportional integral (PI) controller, MATLAB/SIMULINK.*

I. INTRODUCTION

Since the time of industrial revolution Electrical machines are the integral part of manufacturing industries and their advancement is responsible for development held in the field in subsequent years. Electrical machines comprise of different type of motors ranging from induction to reluctance motor, used based on requirement. But out of all this motors AC and DC motors are the one which are most popular. Traditionally both these motors are controlled manually, in case of DC motor Resistance control (field current) is applied and in case if AC motors Variac control is used. This controlling is extinct due to the development of power electronic devices which made the controlling smoother and more efficient while reducing loses and is considered to be more stable. With these devices three conventional techniques became very popular named as proportional (P), proportional integral (PI), proportional integral derivative (PID). although such controllers have a major drawback that they possess slow response to load variation thus making system less sensitive.

One alternative solution for this problem can be Artificial intelligence which comprises of artificial neural network, Genetic Algorithm, ANFIS, Evolutionary algorithm etc. All this algorithm has a property to extract meaning from data and provide expert decision over any situation where output is to be optimized based upon varying input. This

technique is widely used in the field of soft computing in last couple of decades. In recent times its use in social networking, stock market analysis, Face Recognition, Sentiment analysis are few to talk about. It brought a revolution in this field because it has the ability to handle any amount of data with acute preciseness. The method also finds prime application in solving some of the problems of electrical engineering domain. These problems include Load demand forecasting, Solar-wind power estimation, Fault diagnosis etc. are the few to name. This technique is marginally used in the field of power electronics and Induction motor drives; hence an attempt is made in this work to utilize this technique successfully in speed control application and compare its efficiency with conventional to prove its superiority.

II. LITERATURE REVIEW

In the following section a brief discussion of work done in the field of speed control of induction motor using various techniques is discussed.

Zhen Guoa,b et. al. [2] in 2017 discussed that that medium voltage induction moto drives are mostly based on either VSI or CSI. In last few years CSI has been more popular amount the two due its basic topology, super-efficient SC protection and power reversal ability. With separate control of motor flux and motor torque with the help of direct and quadrature component CSI's performance has been further improved making it more popular but it faced a drawback of poor dynamic response. Hence the author has felt the requirement of more efficient CSI based method for IM. For that author has utilized two PI controllers and a rotor flux observer. The utilized method is simulated over MATLAB Simulink software and both dynamic and transient response are obtained after simulation which resulted in more stable performance has been produced.

Shoeb Hussain, Mohammad Abid Bazaz [4] in 2016 developed a neural network model based on observer method for the controlling of 3phase IM. Further based on this model author has developed a fuzzy logic-based model for speed controlling. The complete work is done on MATLAB platform. This work has discussed and proved that such models require less mathematical modelling and less prior knowledge of system also. On simulating IM drives the output functions are observed based on varying load and speed. Which concluded that the proposed method will have more accurate and easy controlling.

Abolfazl Halvaei Niasar and Hossein Rahimi Khoei [5] in 2015 proposed an IM drive based on a technique which utilizes the DPC. Author has discussed that how an old model can be replaced by a new neural network-based model which control the drives speed with the help of backpropagation training and learning. The drive thus developed is not only prove to be cheap and less bulky but also found out to be better performing. Such model is used to estimate both speed and position of IMs rotor.

Tiago Henrique dos Santosa et. al. [6] in 2014 explained how important IM drives are for the sack of industrial operation. In sector where variable load prevails is supplied with similar torque using IM drives. In many of this drives controlling is done using direct measurement. According to author in order to reduce the robustness and cost incorporated due to such techniques a new alternate way to optimize same can be achieved using VSI and space vector modulation. Along with author has also propose ANN by validating performance under motor load torque and speed ref. point variation.

Taifour Ali et. al. [7] in 2014 depicted that how non-linearity of any IM drive can be traced and its performance can be improved using different controller techniques. In this work author has shown a comparative result between PI and ANN controlled for 3 Phase IM. The models are prepared in MATLAB/SIMULINK software. The result clearly states the superiority of ANN trained model over conventional controller due to its exceptional learning capacity hence did trace the reference speed with great accuracy for better and faster than that of conventional one.

Moinak Pyne et al. [8] in 2014 discussed the importance of studying 3 phase induction motor drives performance characteristics due to its extensive use in almost all sectors around the globe. The demand requires a good controlling which is difficult to do using conventional controllers due to non-linear property of speed torque characteristics. This problem is solved by author using artificial neural network and came to the conclusion after proper training and testing and validation that this model with provide better speed controlling of IM drive with the change in input voltage.

Aakanksha Tripathi, Naveen Asati [9] in 2013 explained how certain parameter like varying load, varying input parameters and unmodelled dynamics are common in all sector. Such characteristics still demands a wide range of rotor speed variation scale along with quick torque response for IM drive. Hence

a demand for a controlling technique to have the ability satisfy both the demands is always there. In post couple of decades, a reduction in price of power electronics devices has made IM drives far better option than DC motor drives. These drives comprise of PWM inverters which provide wide frequency control with varying voltage control. In this work author has utilized sliding mode control techniques on IM drives and its results has been presented.

III. METHODS OF SPEED CONTROL OF IM DRIVE

The speed of rotor (N_r) of IM is expressed in the form of synchronous speed (N_s) and slip as

$$N_r = N_s(1 - S)$$

$$\text{Also } N_s = \frac{120f}{p}$$

$$N_r = \frac{120f(1 - S)}{p}$$

From the above equation it's been pretty clear that in order to control the speed of IM one need to vary one or more parameters out of the following

- Number of poles
- Frequency of supply
- Slip

Following are different methods of controlling speed of a 3 ϕ induction motor by modifying one or more of above parameters. The classification of different method is done on the basis of stator and rotor side control. The methods are explained in detail in subsequent section.

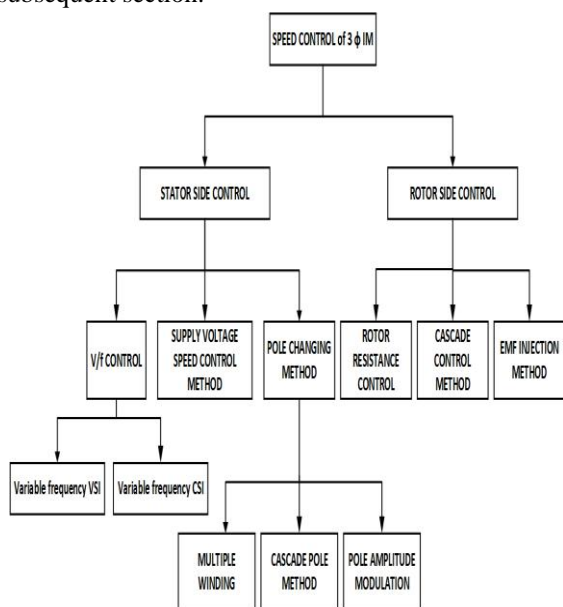

Fig Methods of Speed Control of 3 ϕ IM

IV.METHODOLOGY:

Fuzzy sets have replaced the probability theory to represent the uncertainties of real-world problem. The problem with probability theory comes with fact that they can handle only one uncertainty, which is replaced fuzzy sets introduced by prof. L.A. Zadeh in the in the year 1965. For example: let take height of a person.

In case of crisp set only two cases arise:

$$\text{Height} = \begin{cases} \text{Tall} \\ \text{Short} \end{cases}$$

Now if some one's height is tall then membership value is 1 else value will be 0. Whereas same problem when represented in fuzzy logic. The height of person can have many different categories with different peoples have different choices over it for the same height of person. For example, in east India the average height is usually 5'6". Hence for them a person with height 5'10" is tall whereas same person for people of Punjab or Haryana where average height is 5'10" is of average height. Hence same height of any individual can be categorized differently by different person.

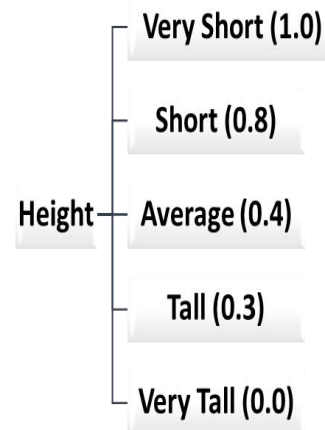

Fig Case representation in fuzzy logic with membership value

Here in above figure membership function value denotes the degree of beloniness.

Representation of Fuzzy Set:

$$A(x) = \{x, \mu_A(x), x \in X\}$$

μ denotes membership value (valued between 0.0 to 1.0)

Probability is the frequency of likelihood that an element is in a class. Membership is similarity of an element to a class. In the further section we will understand the difference between two, with the help of an example.

Suppose we need to buy red apples. Now the first thing that will be our concern is the availability of

apples in the market. This problem will be handled by probability. Whereas the apple we bought will be red or not have some uncertainties in it which can be solved using fuzzy with the help of membership function.

In this block diagram of Mamdani approach of fuzzy logic controller, fuzzification module represent the process of determining membership function value of any input command. After this module the result are supplied to fuzzy interface engine where this result is compared with fuzzy rule base and all fired rules are taken into account for further calculation of outputs.

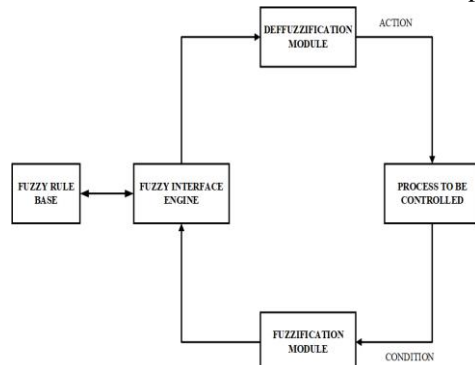

Fig. Block Diagram of Mamdani approach of FLC

These outputs are fuzzified outputs. Now to obtain crisp output we will use defuzzification module. Hence an appropriate action in the form of this output is obtained. To calculate the fuzzified output corresponding to all fired rules, “OR” operator (or max function) is used.

The below figure represents the steps involved in controlling speed of any IM using fuzzy logic controller. The work starts with the defining of inputs and outputs for given problem. Now each of this inputs and outputs must be represented in the form of respective membership function with different range and different width of different categories, making each membership function unique for the particular input parameter.

After defining membership function the next step is to develop rule base using knowledge base by expert opinion. These rules are defined based on if then conditional statement. Once these rules are formed a simulation is done based on input and output data. Based on this data error is calculated on forecasted and actual value of output parameter. After evaluation of error a comparison is done with the required optimum error value. If target is reached then no further training is required and process will end, otherwise a further tuning of the process is done to improve result and same steps are followed again.

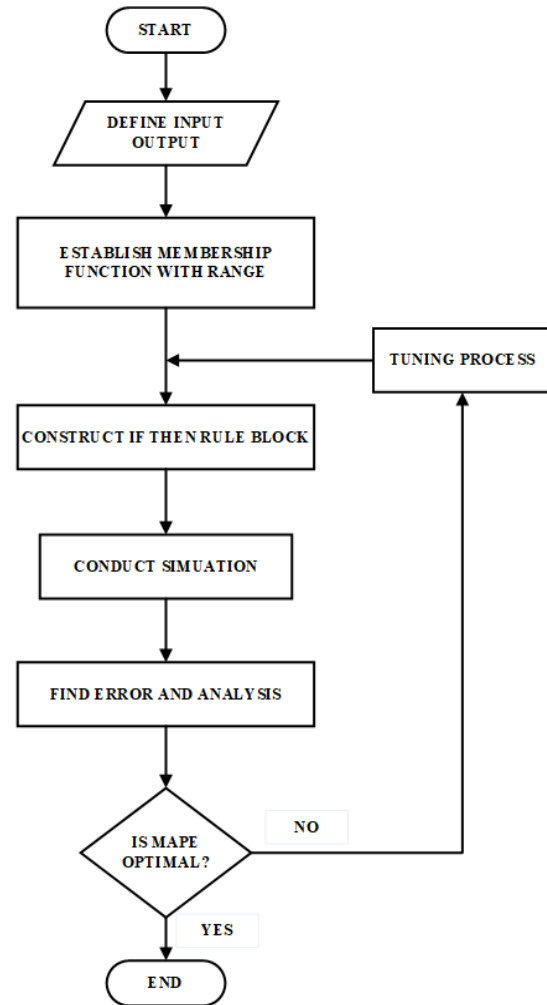

Fig. Flow chart for fuzzy logic model.

V. SIMULINK MODELS AND RESULTS

In present work a comparative study of results of speed controlling of IM using PI controller and fuzzy logic controller is done. We have understood the basic terminologies related to last chapter 4. In this chapter we will discuss PI controller in very brief since they are commonly understood to all. Also, they will be followed by simulation models of both technologies along with their results and finally comparison of two is done.

• V/f Control and Pi Controller-Based Speed Control Model and Results

In present work in order to trace the reference speed curve the first technique utilizes is closed loop controller comprises of V/f control method along with PI controller. This two combinedly will help in checking the speed of rotor.

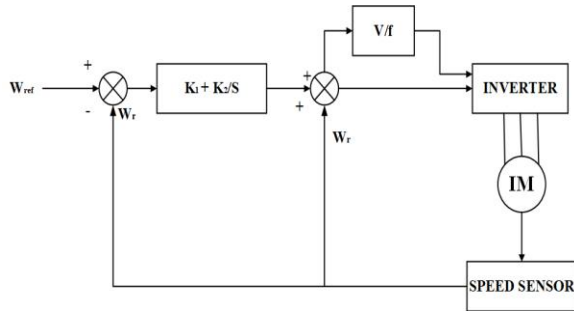

Fig V/f & PI controller block diagram

The V/f control is used here to generate the i/p signal for inverter is feed by PI controller after calculating error signal and limiting slip value. The signal will guide inverter to generate respective supply so as to keep motor speed constant as required with the variation in load. The work is done on MATLAB/SIMULINK software. The signal is feed to VSI which is further connected to IM to supply 3 ϕ power. On simulating the above model following results are obtained.

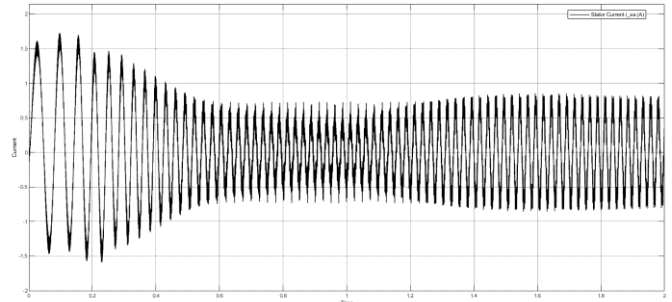

Fig. Stator current of a 3 phase IM speed control induction motor for PI control for V/f control method

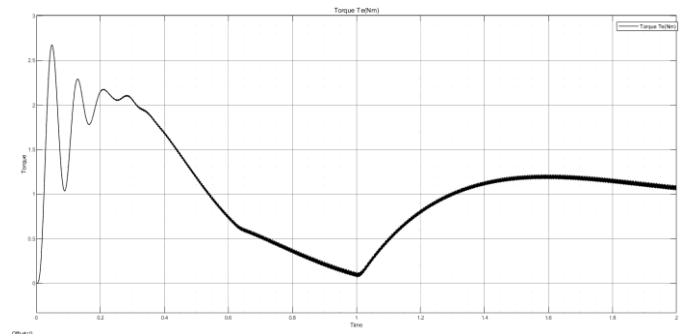

Fig. torque vs. Time of a 3 phase IM speed control induction motor for PI control for V/f control method

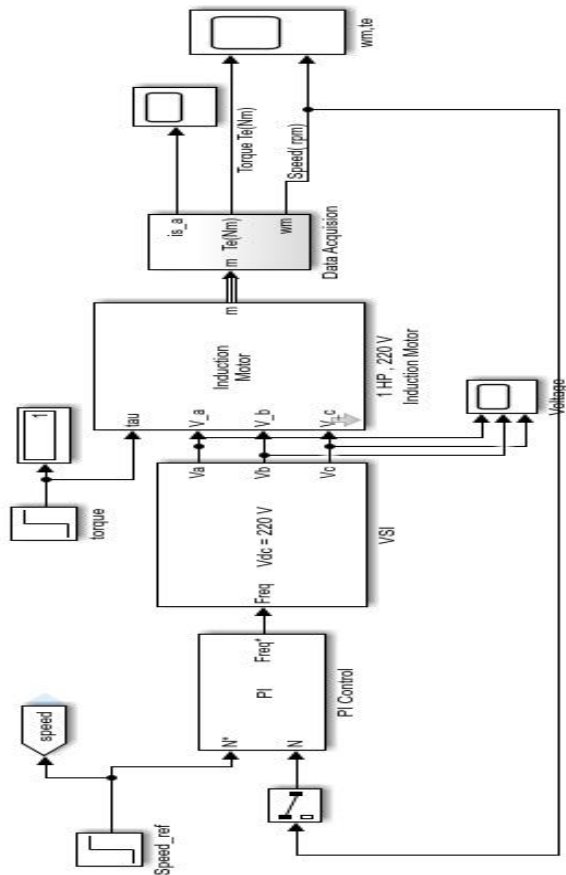

Fig. Simulink Block diagram for 3 phase IM speed control induction motor for PI control for V/f control method

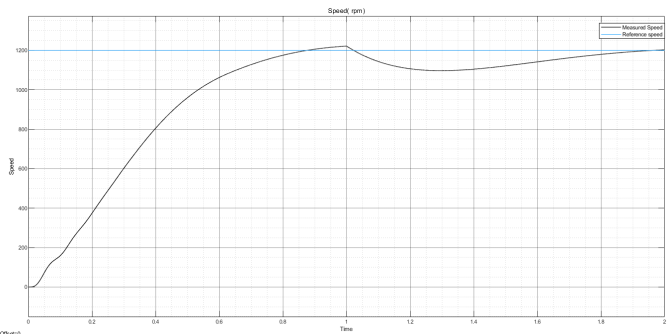

Fig. Speed vs. Time of a 3 phase IM speed control induction motor for PI control for V/f control method

• **FLC Controller-Based Speed Control Model and Results**

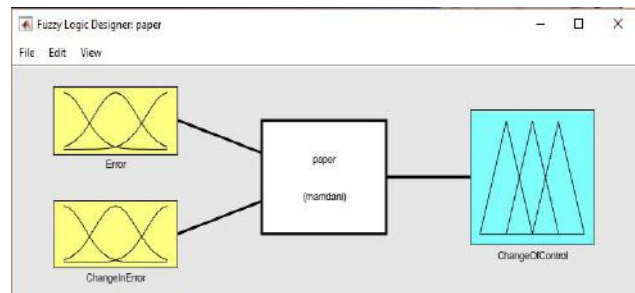
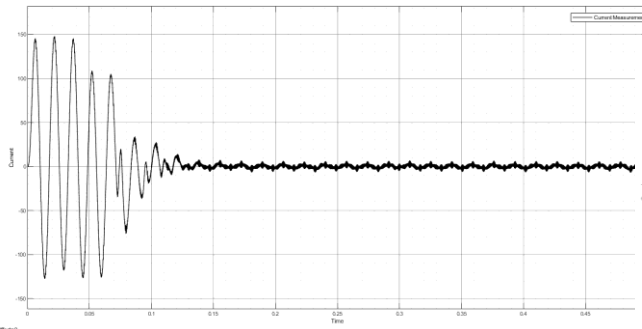

Fig. FIS Editor: rules window



Fig, Stator Current vs time plot using Fuzzy controller

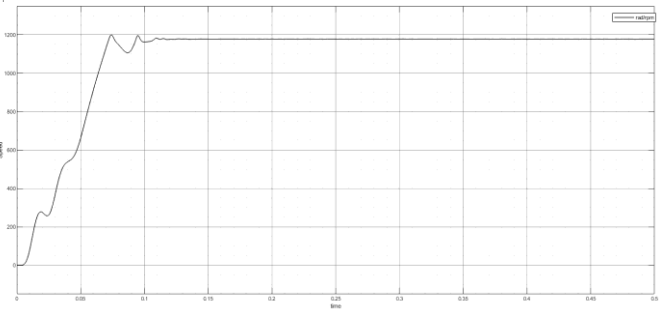
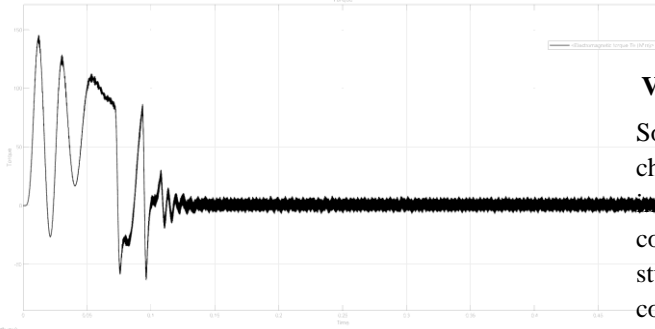

Fig. Speed vs. Time plot using Fuzzy controller



Fig, Torque vs time plot using Fuzzy controller

VII. CONCLUSION

So far in this work a thorough study of various characteristics and fundamentals of a IM drive. Also, this work a detail analysis of requirement of speed control and various method to do so have been studied. In this work a comparative analysis of a conventional (PI) controller and fuzzy controller has been done for the effective controlling of speed of IM drive.

On comparing the results of two techniques, FLC has clearly surpassed the efficiency by which controller follow the required pattern of speed req. to operate a variable load. This advancement in behavior by FLC came due to its simple design and less complex mathematical.

REFERENCES

[1] Jakub Talla ; Viet Quoc Leu ; Václav Šmídl ; Zdeněk Peroutka, “Adaptive Speed Control of Induction Motor Drive With Inaccurate Model”, IEEE Transactions on Industrial Electronics, Volume: 65 , Issue: 11 , pp 8532 – 8542, 2018.

[2] Zhen Guoa,b, Jiasheng Zhang, Zhenchuan Sun, Changming Zheng, “Indirect Field Oriented Control of Three-Phase Induction Motor Based on Current-Source Inverter”, 13th Global Congress on Manufacturing and Management, GCM 2016, Procedia Engineering 174, pp 588 – 594, 2017.

[3] Morawiec, Zbigniew Krzeminski and Arkadiusz Lewicki, “Voltage multi scalar control of induction machine supplied by current source converter,” IEEE, pp. 3119-3124, 2010.

[4] Shoeb Hussain, Mohammad Abid Bazaz, “Neural Network Observer Design for Sensor less Control of Induction Motor Drive”, IFAC 49-1, pp 106–111, 2016.

[5] Abolfazl Halvaei Niasar and Hossein Rahimi Khoei, “Sensor less Direct Power Control of

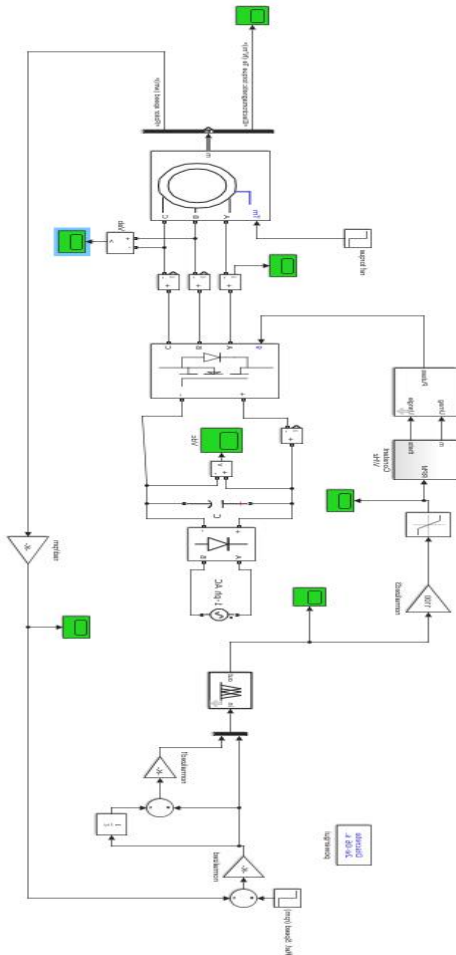

Fig. Block diagram of Fuzzy Logic based Speed controller

- Induction Motor Drive Using Artificial Neural Network”, Hindawi Publishing Corporation Advances in Artificial Neural Systems Volume, 2015.
- [6] Tiago Henrique dos Santosa, Alessandro Goedtelb, Sergio Augusto Oliveira da Silvab, Marcelo Suetake, “Scalar control of an induction motor using a neural sensorless technique”, *Electric Power Systems Research* 108, pp. 322–330, 2014.
- [7] Taifour Ali, Abdelaziz Y. M. Abbas, Ekram Hassabo Abaid Osman, “Control of Induction Motor Drive using Artificial Neural Network”, *SUST Journal of Engineering and Computer Science (JECS)*, Vol. 15, No. 2, 2014.
- [8] Moinak Pyne, Abhishek Chatterjee, Sibamay Dasgupta, “Speed estimation of three phase induction motor using artificial neural network”, *International Journal of Energy and Power Engineering*. Vol. 3, No. 2, pp. 52-56, 2014.
doi: 10.11648/j.ijepe.20140302.13
- [9] Aakanksha Tripathi, Naveen Asati, “Artificial Neural Network Controller for Induction Motor Drive”, *International Journal of Science and Research (IJSR) ISSN (Online): 2319-7064 Index Copernicus Value*, 2013.
- [10] Azuwien Aida Bohari, Wahyu Mulyo Utomo, Zainal Alam Haron, Nooradzianie Muhd. Zin, Sy Yi Sim, and Roslina Mat Ariff, “Speed Tracking of Indirect Field Oriented Control Induction Motor using Neural Network”, *International Conference on Electrical Engineering and Informatics (ICEEI 2013)*, *Procedia Technology* 11, pp 141 – 146, 2013.
- [11] Xiaodong Sun, Long Chen, Zebin Yang, and Huangqiu Zhu, “Speed Sensorless Vector Control of a Bearing less Induction Motor with Artificial Neural Network Inverse Speed Observer”, *IEEE/ASME Transactions on Mechatronics*, Vol. 18, No. 4, pp 1357-1366, 2013.
- [12] S. Hussain, M. A. Bazaz, “Sensorless Control of PMSM using Extended Kalman Filter with Sliding Mode Controller”, 2014 *IEEE International Conference on Power Electronics, Drives and Energy Systems (PEDES)*, pp. 1-5, 2014.
- [13] M. Valizadeh, M. R. Feyzi, E. Babaei, M. Sabahi, "Dynamic modeling of modular fuel cell for maximum power point tracking and torque ripple reduction in direct torque control of induction motor", *Turkish Journal of Electrical Engineering & Computer Sciences*, vol. 23, pp. 317-334, March 2015.
- [14] J. Yu, Y. Ma, H. Yu, Ch. Lin, "Adaptive fuzzy surface control for induction motors with iron losses in electric vehicle drive systems via backstepping", *Inf. Sci.*, vol. 376, no. 1, pp. 172-189, Jan. 2017.
- [15] N. Singh, V. Agarwal, "Delta-Modulated AC-AC Converter for PM WECS", *IEEE Transactions on Industrial Informatics*, vol. 11, no. 6, pp. 1422-1434, Dec. 2015.
- [16] C. M. F. S. Reza, M. D. Islam, and S. Mekhilef, “A review of reliable and energy efficient direct torque-controlled induction motor drives,” *Renew. Sustain. Energy Rev.*, vol. 37, pp. 919–932, Sep. 2014.
- [17] P. Agarwal, P. Sonkar, V. Agarwal, "Single Phase to three phase cyclo-inverter with Space Vector PWM controller", 2012 *IEEE International Conference on Power Electronics Drives and Energy Systems (PEDES)*, pp. 1-5, 2012
- [18] S. Golabi, E. Babaei, M. B. Bannae Sharifian, Z. Golabi, "Application of speed rotor flux electromagnetic load torque observers and diagnostic system in a vector controlled high-power traction motor drive", *Arabian Journal for Science and Engineering (AJSE)*, vol. 39, no. 4, pp. 2979-2996, April 2014.
- [19] F. Wang, Z. Zhang, X. Mei, J. Rodríguez, and R. Kennel, “Advanced Control Strategies of Induction Machine: Field Oriented Control, Direct Torque Control and Model Predictive Control,” *Energies*, vol. 11, no. 1, p. 120, 2018
- [20] S.-M. Lu, “A review of high-efficiency motors: Specification, policy, and technology,” *Renew. Sustain. Energy Rev.*, vol. 59, pp. 1–12, Jun. 2016.
- [21] H. Krisztián and K. Márton, “Speed Sensorless Field Oriented Control of Induction Machines Using Unscented Kalman Filter,” in *Proceedings of the IEEE International Conference OPTIM & Intl ACEMP*, pp. 25–27, Brasov, Romania, 2017
- [22] P. Tiwari, N. K. Mtshra, S. K. Mkhra, "Comparative analysis of 3-phase induction motor fed from balanced and unbalanced power supply", *International Journal of Electrical and Electronics Engineering Research*, vol. 4, no. 2, pp. 349-356, April 2014.
- [23] P. Kjaer, T. Kjellqvst and C. Delaloye, “Estimation of field current in Vector controlled Synchronous Machine Variable Speed Drives Employing Brushless Asynchronous Exciters”, *IEEE Trans. on Industry Applications*, Vol. 41(3), pp: 834–840, 2005.
- [24] R. Zhao, Z. Xin, P. C. Loh, and F. Blaabjerg, “A Novel Flux Estimator Based on Multiple Second-Order Generalized Integrators and Frequency-Locked Loop for Induction Motor Drives,” *IEEE*

Transactions on Power Electronics, vol. 32, no. 8, pp. 6286–6296, 2017.

[25] A. T. de Almeida, J. Fong, H. Falkner, and P. Bertoldi, “Policy options to promote energy efficient electric motors and drives in the EU,” *Renew. Sustain. Energy Rev.*, vol. 74, pp. 1275–1286, 2017