

# Power Quality Improvement of Hybrid Power system based microgrid using UPQC

**Authors: Mr. Mohit Dehariya<sup>1</sup>; Mr. Pawan Pandey<sup>2</sup>**

<sup>1</sup> M. Tech Scholar in Power Electronics, MIT, Indore (M.P). E-mail: (mdehariya9340@gmail.com)

<sup>2</sup> Assistant Professor & head in Electrical & Electronics Dept. MIT, Indore (M.P). E-mail: (pawanpandey@mitindore.co.in)

## **Abstract:**

The advance use of power electronic devices introduces harmonics in the supply system which creates a problem in the quality of power delivered. Good Power Quality is very much important for our day-to-day use of appliances in both industrial and domestic sectors. Researchers have tried and implemented many useful technologies for removing all the voltage and current related harmonic occurrence problems which in turn improves the quality of power delivered to the power system. The prime focus of this thesis is the implementation of control strategies like SRF theory and instantaneous power (p-q) for the operation of Unified Power Quality Conditioner (UPQC) which is one of the recent technologies that includes both series and shunt active power filter operating at the same time and thereby improves all the current and voltage related problem like voltage sag/swell, flicker, etc. at the same time and helps in reduction of Total Harmonic Distortion (THD).

In this work it is shown via MATLAB simulation how UPQC model can be used to decrease the % THD in source voltage, source current and load voltage waveforms created due to non-linear/sensitive loads usage.

*Keywords: Renewable energy sources, Power quality, Harmonic analysis, Synchronization, Voltage control, UPQC, MATLAB.*

## **1. Introduction**

In the present scenario non-linear loads have become extremely important and people are becoming dependent on it. Few of these non-linear loads are televisions, printing and fax machines, rectifiers, inverters, speed drives, AC, etc. Harmonics are introduced in the lines due to the extensive use of these loads in our everyday purpose. The stability of any electrical devices

depends on its voltage and current waveforms. If the fundamental waveform is sinusoidal, and its harmonics are sinusoidal too then these harmonics occurs in integral multiples of the fundamental waveform. Due to this harmonic distortion created by nonlinear loads several problems are caused in the appliances used in our purpose like: motor getting overheated, increase in several types of losses, permanent damage of equipment in the worst case, high error in meter reading, etc. Hence removal of these harmonics or harmonic mitigation from voltage and current waveforms are of great concern for electrical engineers. Due to the harmonic's introduction in the lines by the nonlinear loads other problems of concern are voltage swell, voltage sag, flicker occurring in voltage, etc and thereby disturbing the overall power supply.

In older days passive filters using tuned LC components were in very much use for improvement of power quality by removing voltage and current harmonics. But due to its high cost, resonance problems, large size and many more these filters are not in much use in the present days. All these problems are now improved by the use of active power filters (APF) and more advanced hybrid filters using several new technologies. Series Active Filter is utilized for mitigation of voltage quality problems and Shunt Active Filter (SAF) is helpful for removing the disturbances present in the current waveforms.

## **2. Introduction to UPQC**

The Unified Power Quality Conditioner is a custom power device that is employed in the distribution system to mitigate the disturbances that affect the performance of sensitive and/or critical load. It is a type of hybrid APF and is the only versatile device which can mitigate several power quality problems related with voltage and current simultaneously therefore is multi functioning devices that

compensate various voltage disturbances of the power supply, to correct voltage fluctuations and to prevent harmonic load current from entering the power system. Fig. 2.1 shows the system configuration of a single-phase UPQC. Unified Power Quality Conditioner (UPQC) consists of two IGBT based Voltage source converters (VSC), one shunt and one series cascaded by a common DC bus. The shunt converter is connected in parallel to the load. It provides VAR support to the load and supply harmonic currents. Whenever the supply voltage undergoes sag then series converter injects suitable voltage with supply. Thus, UPQC improves the power quality by preventing load current harmonics and by correcting the input power factor.

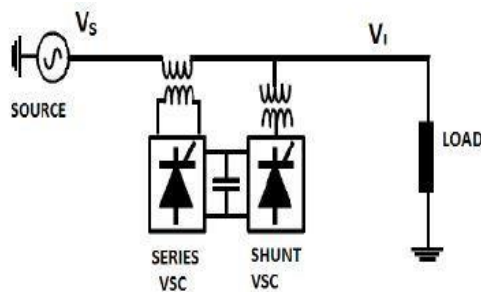

Figure 1: Block diagram of UPQC

The main components of a UPQC are series and shunt power converters, DC capacitors, low-pass and high-pass passive filters, and series and shunt transformers:

### 2.1 Equivalent circuit

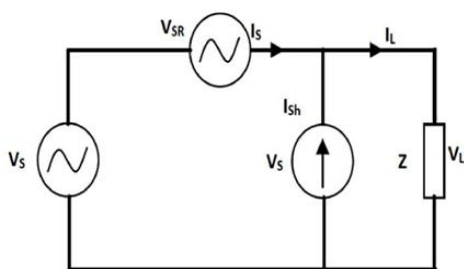

Figure 2: equivalent circuit for UPQC

In this circuit,

$V_S$  represents the voltage at power supply  
 $V_{SR}$  is the series-APF for voltage compensation,  
 $V_L$  represents the load voltage and  
 $I_{sh}$  is the shunt-APF for current and  $V_{SR}$  compensation.

Due to the voltage Distortion, the system may

contain negative phase sequence and harmonic components. In general, the source voltage in Figure 2.2 can be expressed as:

$$V_s + V_{sr} = V_L \quad (2.1)$$

To obtain a balance sinusoidal load voltage with fixed amplitude  $V$ , the output voltages of the series-APF should be given by:

$$V_{sr} = (V - V_{1P}) \sin(\omega t + \theta_{1P}) - V_{Ln} \left( \sum_{K=2}^{\infty} V_K(t) \right) \quad (2.2)$$

where,  $V_{1P}$ : positive sequence voltage amplitude  
 fundamental frequency

$\theta_{1P}$ : initial phase of voltage for positive sequence

$V_{Ln}$ : negative sequence component

The shunt-APF acts as a controlled current source and its output components should include harmonic, reactive and negative-sequence components in order to compensate these quantities in the load current, when the output current of shunt APF  $i_{sh}$  is kept to be equal to the component of the load as given in the following equation:

$$i_L = I_{1P} \cos(\omega t + \theta_{1P}) \sin \phi_{1P} + i_{Ln} + \sum_{K=2}^{\infty} i_{LK} \quad (2.3)$$

$$\phi_{1P} = \phi_{1P} - \theta_{1P} \quad (2.4)$$

where,  $\phi_{1P}$ : initial phase of current for positive sequence

As seen from the above equations that the harmonic, reactive and negative sequence current is not flowing into the power source. Therefore, the terminal source current is harmonic-free sinusoid and has the same phase angle as the phase voltage at the load terminal

$$i_s = i_L - i_{sh} \\ = I_{1P} \sin(\omega t - \theta_{1P}) \cos \phi_{1P} \quad (2.5)$$

## 3. Control Strategy for UPQC:

### 3.1 d-q transformation:

Both active and reactive power is controlled by controlling magnitude and phase of converter voltage with line voltage, because we know that the active power flow from leading to lagging voltage and reactive power from higher to lower voltage. D-q transformation controls both the power independently by controlling phase and magnitude.

According to d-q theory three phase system is converted into equivalent two-phase system known as stationary reference frame. These then converted into synchronous reference frame. In synchronous reference frame active and reactive power current control independently. The three phases to d-q and vice versa transformation is discussed later. Dc bus voltage and line current is controlled by outer loop and inner loop respectively. The instantaneous power of the line is:

$$p = v_R I_R + v_Y I_Y + v_B I_B \quad (3.1)$$

The reactive voltage is eliminated at any instant without changing  $p$ . In three phase circuit voltage and current is expressed as space vector. Three phases R, Y and B displaced by  $2\pi/3$  from each other shown in Figure 3.

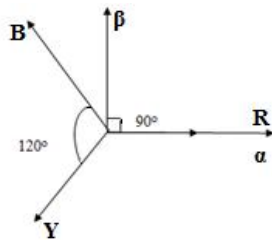

Figure 3: Vector Representation of R, Y, B (Frame Transformation abc to  $\alpha\beta$ )

The space vector instantaneous voltage and current is expressed as instantaneous voltage and current:

$$v = [v_R \quad v_Y \quad v_B] \\ I = [I_R \quad I_Y \quad I_B] \quad \dots (3.2)$$

Instantaneous voltage and current is converted into  $\alpha, \beta$  by using Clarke transformation:

$$\begin{bmatrix} v_\alpha \\ v_\beta \\ v_0 \end{bmatrix} = T \begin{bmatrix} v_R \\ v_Y \\ v_B \end{bmatrix} \quad \dots (3.3)$$

$$\begin{bmatrix} I_\alpha \\ I_\beta \\ I_0 \end{bmatrix} = T \begin{bmatrix} I_R \\ I_Y \\ I_B \end{bmatrix} \quad \dots (3.4)$$

Where Transformation Matrix

$$T = \sqrt{2/3} \begin{bmatrix} 1 & -1/2 & -1/2 \\ 0 & \sqrt{3}/2 & -\sqrt{3}/2 \\ 1/\sqrt{2} & 1/\sqrt{2} & 1/\sqrt{2} \end{bmatrix} \quad \dots (3.5)$$

In balanced three-phase three-wire system zero sequence current is not present and it is also eliminated using star delta transformer. The reference frame  $\alpha, \beta$  is converted into d-q reference frame shown in Figure 4.

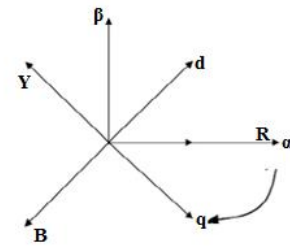

Figure 4:  $\alpha\beta$  to dq Transformation

$$\begin{bmatrix} v_d \\ v_q \end{bmatrix} = T \begin{bmatrix} v_\alpha \\ v_\beta \end{bmatrix} \quad \dots (3.6)$$

$$\begin{bmatrix} \cos \omega_r & -\sin \omega_r \\ \sin \omega_r & \cos \omega_r \end{bmatrix} \quad \dots (3.7)$$

Where,  $\omega_r$  = angular velocity of d-q reference frame shown in Figure 4. The current is also obtained similarly using transformation matrix  $T$ .

#### 4. Simulation Model

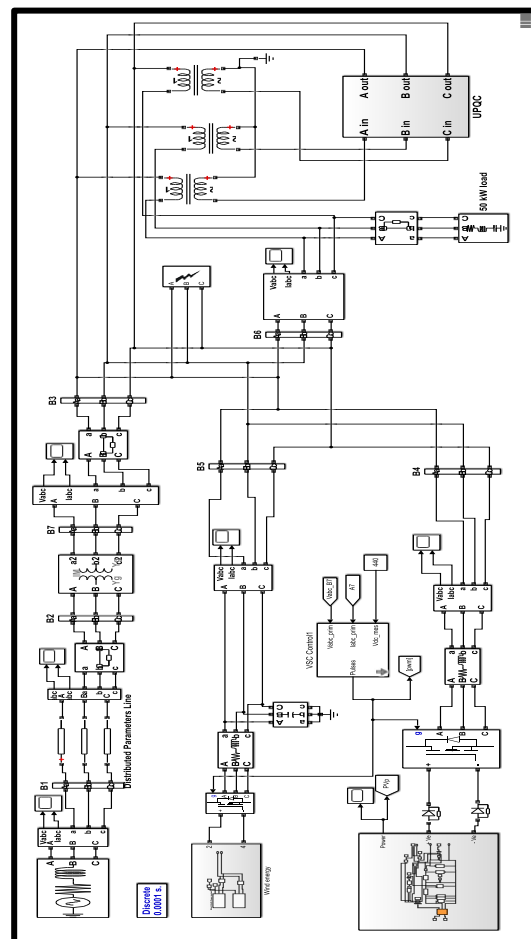

Fig 5 Simulation model with UPSC

#### 4.1 SIMULINK result for LLLG fault case

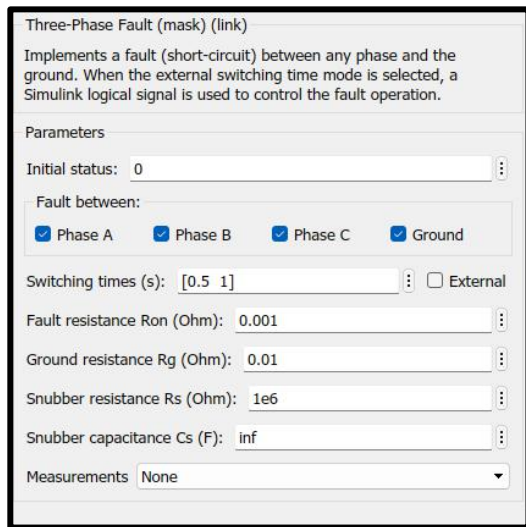

Fig 6 Three phase fault parameters for LLLG fault

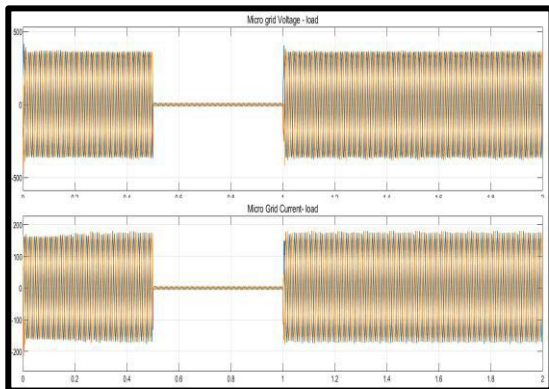

Fig 7 Voltage and current waveform of Micro Grid for LLLG fault

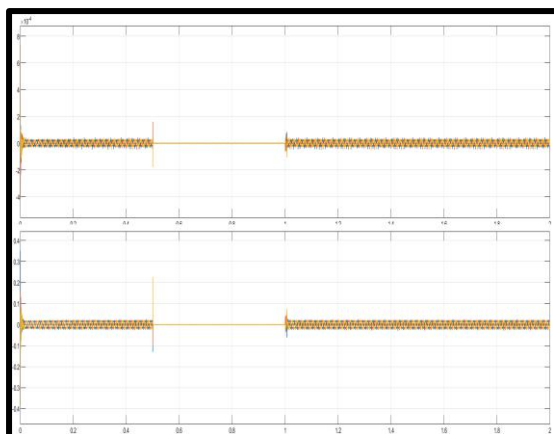

Fig 8 Voltage and current waveform of Along UPQC for LLLG fault

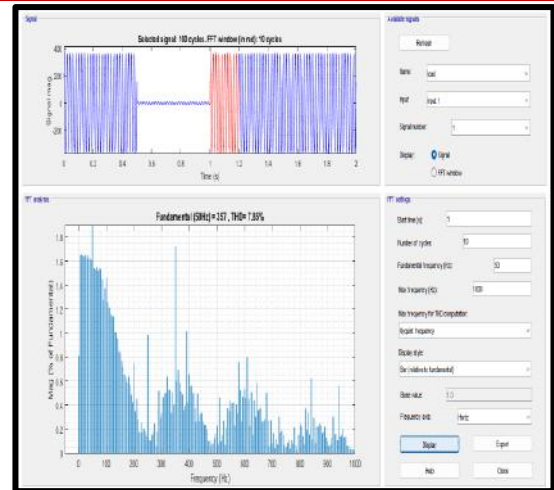

Fig 9 THD for LLLG fault

#### 4.2 SIMULINK result for LLL fault case

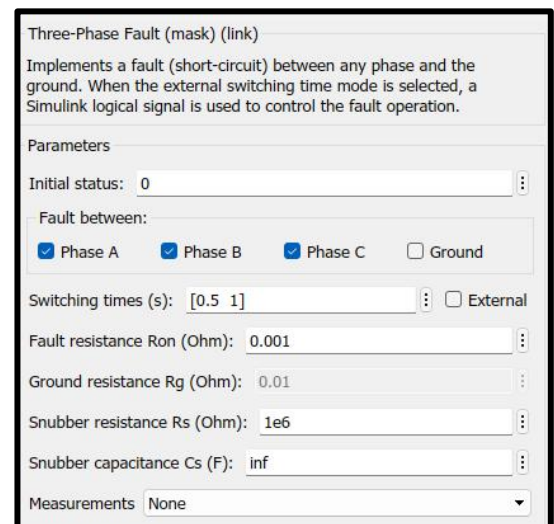

Fig 10 Three phase fault parameters for LLL fault

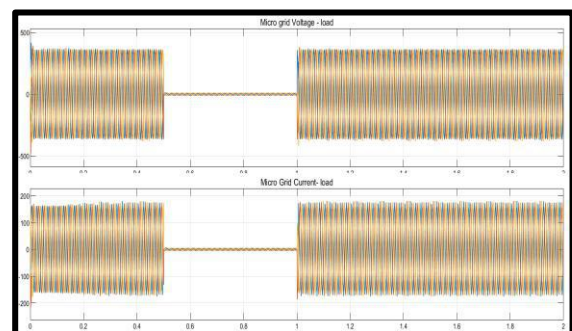

Fig 11 Voltage and current waveform of Micro Grid for LLL fault

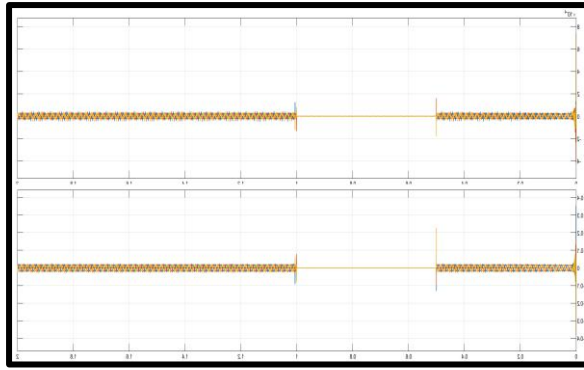

Fig 12 Voltage and current waveform of Along UPQC for LLL fault

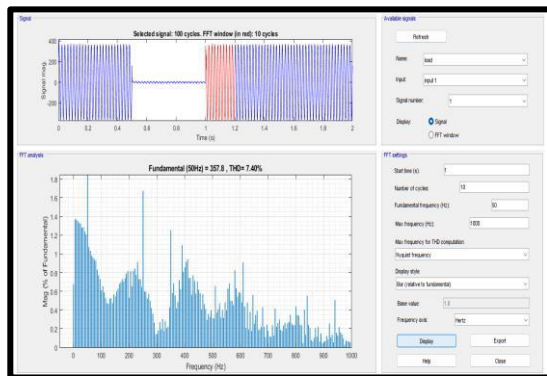

Fig 13 THD for LLL fault

## 5. CONCLUSION

This thesis describes an improved control strategy for the operation of UPQC system. The UPQC model is simulated in MATLAB using instantaneous power theory. Shunt part of UPQC removes all the current related harmonic problems in the system and series connected APF of UPQC system removes all voltage harmonics which comes up due to the use of nonlinear load. The overall THD is now improved in the system which is clearly observed from the waveforms. The value of THD is found to be near about 7.5 %.

### References:

[1] S. Samal and P. K. Hota, "Design and analysis of solar PV-fuel cell and wind energy based microgrid system for power quality improvement," *Cogent Engineering*, vol. 4, no. 1, p. 1402453, Jan. 2017, doi: 10.1080/23311916.2017.1402453.

[2] Ch. P. Kumar, S. Pragaspathy, V. Karthikeyan, and K. N. S. Durga Prakash, "Power Quality Improvement for a Hybrid Renewable Farm

Using UPQC," in 2021 International Conference on Artificial Intelligence and Smart Systems (ICAIS), Mar. 2021, pp. 1483–1488. doi: 10.1109/ICAIS50930.2021.9396048.

[3] P. G. Khorasani, M. Joorabian, and S. G. Seifossadat, "Smart grid realization with introducing unified power quality conditioner integrated with DC microgrid," *Electric Power Systems Research*, vol. 151, pp. 68–85, Oct. 2017, doi: 10.1016/j.epsr.2017.05.023.

[4] S. K. Yadav and K. B. Yadav, "The Role of BESS and UPQC in PV Integrated Power System for Power Quality Improvement: A Brief Review," in 2021 2nd International Conference on Smart Electronics and Communication (ICOSEC), Oct. 2021, pp. 594–601. doi: 10.1109/ICOSEC51865.2021.9591826.

[5] K. Sarker, D. Chatterjee, and S. K. Goswami, "A modified PV-wind-PEMFCs-based hybrid UPQC system with combined DVR/STATCOM operation by harmonic compensation," *International Journal of Modelling and Simulation*, vol. 41, no. 4, pp. 243–255, Jul. 2021, doi: 10.1080/02286203.2020.1727134.

[6] K. Ravinder and H. O. Bansal, "Investigations on shunt active power filter in a PV-wind-FC based hybrid renewable energy system to improve power quality using hardware-in-the-loop testing platform," *Electric Power Systems Research*, vol. 177, p. 105957, Dec. 2019, doi: 10.1016/j.epsr.2019.105957.

[7] P. Rajesh, F. H. Shajin, B. Rajani, and D. Sharma, "An optimal hybrid control scheme to achieve power quality enhancement in micro grid connected system," *International Journal of Numerical Modelling: Electronic Networks, Devices and Fields*, vol. 35, no. 6, p. e3019, 2022, doi: 10.1002/jnm.3019.

[8] K. Srilakshmi, K. Krishna Jyothi, G. Kalyani, and Y. Sai Prakash Goud, "Design of UPQC with Solar PV and Battery Storage Systems for Power Quality Improvement," *Cybernetics and Systems*, vol. 0, no. 0, pp. 1–30, Mar. 2023, doi: 10.1080/01969722.2023.2175144.

[9] D. S S, M. S. N B, and U. Subramaniam, "Artificial Neural Network based Solar Energy

Integrated Unified Power Quality Conditioner,” Energy Sources, Part A: Recovery, Utilization, and Environmental Effects, vol. 0, no. 0, pp. 1–25, May 2021, doi: 10.1080/15567036.2021.1919247.

[10] S. S. Dheeban and N. B. Muthu Selvan, “ANFIS-based Power Quality Improvement by Photovoltaic Integrated UPQC at Distribution System,” IETE Journal of Research, vol. 69, no. 5, pp. 2353–2371, Jul. 2023, doi: 10.1080/03772063.2021.1888325.

[11] P. Rajesh, F. H. Shajin, and L. Umasankar, “A Novel Control Scheme for PV/WT/FC/Battery to Power Quality Enhancement in Micro Grid System: A Hybrid Technique,” Energy Sources, Part A: Recovery, Utilization, and Environmental Effects, vol. 0, no. 0, pp. 1–17, Jul. 2021, doi: 10.1080/15567036.2021.1943068.

[12] C. R. Reddy, B. S. Goud, F. Aymen, G. S. Rao, and E. C. Bortoni, “Power Quality Improvement in HRES Grid Connected System with FOPID Based Atom Search Optimization Technique,” Energies, vol. 14, no. 18, Art. no. 18, Jan. 2021, doi: 10.3390/en14185812.

[13] R. H. Yang, J. X. Jin, S. Mu, M. S. Zhang, S. Jiang, and X. Y. Chen, “Battery-energy-storage-based triple-active-bridge DC unified power quality conditioner for energy management and power quality enhancement of DC renewable sources,” International Journal of Electrical Power & Energy Systems, vol. 143, p. 108442, Dec. 2022, doi: 10.1016/j.ijepes.2022.108442.

[14] G. R. Reddy, N. K. Rayaguru, K. Karthikumar, P. Chandrasekar, and P. Murthy, “Enhancement of Power Quality With Fuzzy Based UPQC in Grid Integrated and Battery Assisted PV System,” in 2021 2nd Global Conference for Advancement in Technology (GCAT), Oct. 2021, pp. 1–8. doi: 10.1109/GCAT52182.2021.9587595.

[15] W. Choi and B. Sarlioglu, “Comparative Analysis on Performance of Power Quality Improvement of Grid-Connected Inverters,” in 2019 IEEE Energy Conversion Congress and Exposition (ECCE), Sep. 2019, pp. 4281–4286. doi: 10.1109/ECCE.2019.8912488.

[16] Arindam Ghosh, Gerard Ledwich, “A unified power quality conditioner (UPQC) for simultaneous

voltage and current compensation”, Electric Power Systems Research 59, pp. 55-63, 2001.

[17] Hiliny Awad, Math H.J Bollen, “Power Electronics for Power Quality Improvements”, IEEE, pp. 1129- 1136, 2003.

[18] Bhim Singh, Ambrish Chandra, Kamal Al-Haddad, “Computer-Aided Modeling and Simulation of Active Power Filters”, Electric Machines & Power Systems, 27:11, pp. 1227-124, 29 Oct 2010.

[19] I. Wasiak and Z. Hanzelka, "Integration of distributed energy sources with electrical power grid," Bulletin of Polish Academy of Sciences: Technical Sciences, volume 54, issue 7, pp. 297–309, 2009.

[20] A. Moreno-Muñoz (Ed.), “Power Quality: Mitigation Technologies in a Distributed Environment”, London: Springer-Verlag, 2007.

[21] S.L. Chen et al., "Mitigation of voltage sags by network reconfiguration of a utility power system", Transmission and Distribution Conference and Exhibition 2002: Asia Pacific, IEEE PES, volume3, pp. 2067 – 2072, 2002.

[22] G. Benysek, M.P. Kazmierkowski, J. Popczyk, and R. Strzelecki, “Power electronic systems as a crucial part of Smart Grid infrastructure – a survey,” Bulletin of the Polish Academy of Sciences: Technical Sciences, volume 59, issue 4, April 2011.

[23] R. Strzelecki and G. Benysek, Power Electronics in Smart Electrical, London: Springer-Verlag, 2007.

[24] IEEE Std1409-2012, “Guide for Application of Power Electronics for Power Quality Improvement on Distribution Systems Rated 1 kV through 38 kV”, IEEE Power & Energy Society, New York, 2012.

[25] Arindam Ghosh and Gerard Ledwich, “Power Quality Enhancement Using Custom Power Devices”, NEW DELHI: Springer Publications, 2009.

[26] V.Khadkikar, A.Chandra, Barry.A.O and Nguyen.T.D, “Analysis of power flow in UPQC during voltage sag and swell conditions for selection device ratings Industrial Electronics”, IEEE

---

International Symposium on Volume 2, 9-13 May 2006.

[27] Khadkikar V., Chandra A, “A novel structure for three-phase four-wire distribution system utilizing unified power quality conditioner (UPQC)”, Int. Conf. on Power Electronics, Drives and Energy Systems, pp. 1–6, 12–15 December 2006.

[28] Jindal A.K., Ghosh A., Joshi A, “Interline unified power quality conditioner”, IEEE Trans. Power Deliv., , 22, (1),pp. 364–371, 2007.

[29] Basu M., Das S.P., Dubey G.K, “Performance study of UPQC-Q for load compensation and voltage sag mitigation”, Proc. IEEE IECON02, vol. 1, pp. 698–70, November 2002.

[30] Zhang Y., Zhang S., Chen J, “The applications of bidirectional full-bridge DC–DC isolated converter in UPQC”, Int.Conf. On Electrical Machines and Systems, 17–20 October 2008, pp. 1916–1921.

[31] Vilathgamuwa D.M., Wijekoon H.M., Choi S.S, “A novel technique to compensate voltage sags in multilines distribution system – the interline dynamic voltage restorer”, IEEE Trans. Ind. Electron., 53, (5), pp. 1603–1611, 2006.

[32] Sng E.K.K., Choi S.S., Vilathgamuwa D.M, “Analysis of series compensation and DC-link voltage controls of a transformerless selfcharging dynamic voltage restorer”, IEEE Trans. Power Deliv. 19, (3), pp. 1511–1518, 2004.

[33] K.K. Sen, E.J. Stacey, “UPFC - unified power flow controller: theory, modelling, and application”, IEEE PES Winter Meeting, Tampa, FL, PE-282-PWR-0-12-1997.

[34] Afonso, J.L., Freitas, M.J.S., Martins, J.S, “p-q theory power components calculations”, Proc. 2003 IEEE Int. Symp. On Industrial Electronics, vol. 1, pp. 385–390, 9–11 June 2003.