

Solar Array Reconfiguration Techniques for Minimizing Effect of Partial Shading

Authors: Satyam Singh; Imran Khan

Azad Institute of Engineering & Technology, Lucknow

ABSTRACT

This research explores various PhotoVoltaic (PV) array Reconfiguration (PVR) techniques that are utilised to lessen the detrimental effects of Partial Shading Conditions (PSCs) that could impair the performance of a PV system (such as hotspots, electrical mismatch, etc.). Physical, electrical, and physical-electrical combinations are the three basic categories used to classify various PVR approaches. Physical PVR alters the actual locations of the panels within the array. Referred to as static reconfiguration methods, this set includes puzzle based, number based, symmetry based, distance maximizing based, and nature inspired methods. On the other hand, electrical PVR reorders the electrical interconnections between PV panels, and is composed of algorithm based, artificial intelligence based, hybrid, and basic/improved electrical configurations. A combined PVR method hybridizes the two precedent categories. A mathematical model that includes many performance indices, such as Fill Factor (FF), Mismatch Power Loss (λ), Percentage Power Loss (%), Performance Ratio (PR), Execution Ratio (ER), Efficiency (η), Percentage of Power Enhancement (%PE), and DC output power (P_{DC}), is used to compare each method from the three main sets to the pertinent others. A Total Cross Tied (TCT) configuration of PV panels, physically relocated using the Static Shade Dispersion Physical Array Relocation (SD-PAR) algorithm, while interfered with a switching matrix controlled by the Modified Harris Hawks Optimizer (MHHO) algorithm, could be the best and most efficient way to passively mitigate PSC effects, according to a thorough investigation of various PVR techniques.

Key words: PSPV, MPPT, Ant Colony Optimization (ACO), partial shading (PS)

1. Introduction

In addition to the shaded PV modules and arrays themselves, the partial shading condition (PSC) decreases the PSPV system's output power. It makes the hot spot problem worse and makes less power from the photovoltaic (PV) system, which could cause shaded PV modules to fail thermally [1,3]. The P-V curve has two global peaks (GPs) and several local peaks (LPs) under PSC. This chapter's primary goals are to reduce the effects of partial shading and boost the power of the PSPV system as a whole. Under PSC, the best PV system design topologies and maximum power point tracker (MPPT) methods were utilized to track the GP. To extract GP and lessen the PS effects of PSPV systems, there are two types of partial shading (PS) mitigation solutions: Bypass and blocking diodes, PV array setup, and PV array reconfiguration are all topologies for the design of PV systems, as are MPPT strategies [6]. In contrast, MPPT methods concentrate on utilizing the best heuristic MPPT to track the GP under PSC [4,9].

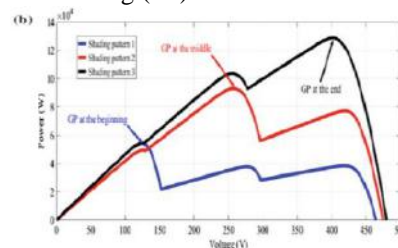

Fig. 1 P-V characteristic of the PV array: a uniform condition and b partial shading conditions.

PV system design topologies and MPPT approaches are the two primary types of partial shading mitigation strategies, as shown in Figure. Topologies for PV systems that aim to reduce PS effects and increase output power will be the focus of this chapter. Topologies used in the design of PV systems include bypass and blocking diodes, layouts for PV systems, configurations for PV arrays, and reconfigurations for PV arrays. In addition, the well-organized heuristic MPPT methods, such as PSO, GWO, and FPA, which are able to track the GP under PSC, will be highlighted.

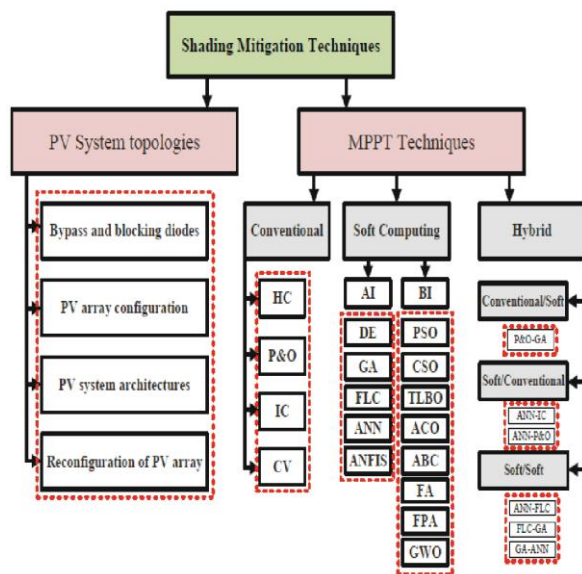

Fig. 2 Techniques for PSPV mitigation are categorized

2. Methodology

2.1 Ant Colony Optimization (ACO):

Insect states, and especially friendly bug social orders, are widely dispersed structures that, despite the ease with which their inhabitants live, have a highly organised social structure. This relationship enables insect colonies to carry out complicated tasks that occasionally much exceed the capabilities of a single underground insect. The field of "insect calculations" focuses on models derived from observations of the behaviour of real underground insects, and uses these models as a source of inspiration for the design of unique calculations for the resolution of augmentation and transmitted control concerns. The main idea is that by setting up populations of fake experts who collaborate to solve computational problems, one may take benefit of oneself getting sorted out norms that allow for the intricately organised behaviour of real insects. Numerous forms of bug calculations have been inspired by a few distinctive aspects of the behaviour of underground insect states. Models include searching, task division, child rearrangement, and acceptable transportation[2,3]. In these many theories, underground insects use stigmergy, a sort of circular connection complicated by climatic fluctuations, to coordinate their movements. For instance, when a scavenger bug stores a substance on the ground, it increases the possibility that other underground insects would do the same.

Researchers have demonstrated that a variety of province-level behaviours in amiable bugs can be explained by simple models that just account for stigmergic correspondence[5]. Therefore, researchers have demonstrated that it is frequently sufficient to take stigmergic, aberrant communication into account in order to understand how social bugs can achieve self-association. The idea behind bug calculations is to use a false form of stigmergy to support phoney expert social orders.

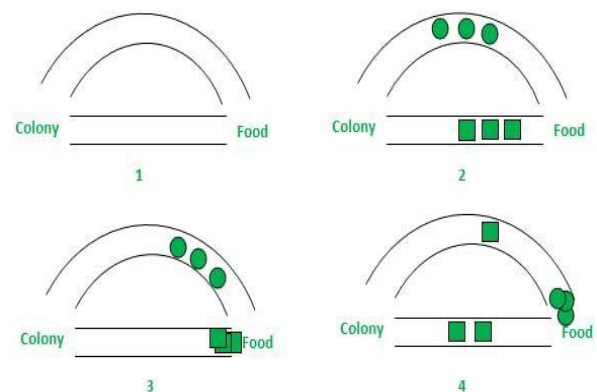

Figure 3: ACO For Finding Food

Swarm understanding, which draws its inspiration from the social behaviours of diverse animals and insects, is, for the most part, a more effective way to think about making decisions[4]. In particular, a multitude of methods have been inspired by insects, the most popular and successful of which is the universally beneficial improvement method known as insect settlement streamlining. Insect state streamlining (ACO) was inspired by a few types of underground insects[4,7]. These underground insects deposit pheromone on the ground to attract the attention of other people living there. In order to resolve concerns with improvement, a comparable approach is used in insect province enhancement. ACO has drawn the interest of a rising number of researchers since the principal insect province enhancement calculation was first proposed in the middle of the 1990s, and there are currently a wide range of helpful applications accessible.

Additionally, a substantial corpus of fictitious findings is growing, offering experts and researchers helpful direction for additional ACO applications.

3. Results and Discussions

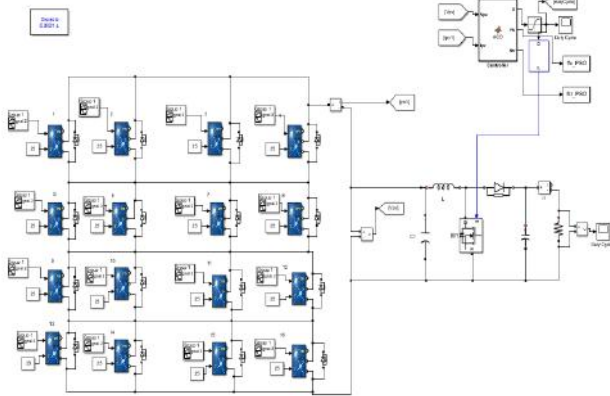

Figure 4: Simulink block model of 4x4 PV array based model.

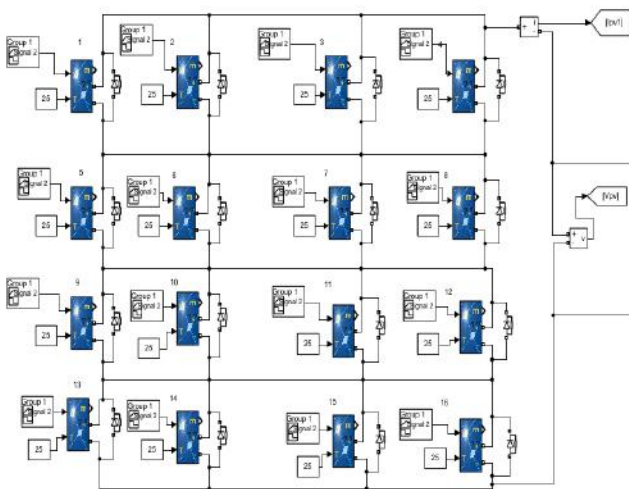

Figure 5: PV array model detailed view for 4x4 based configuration.

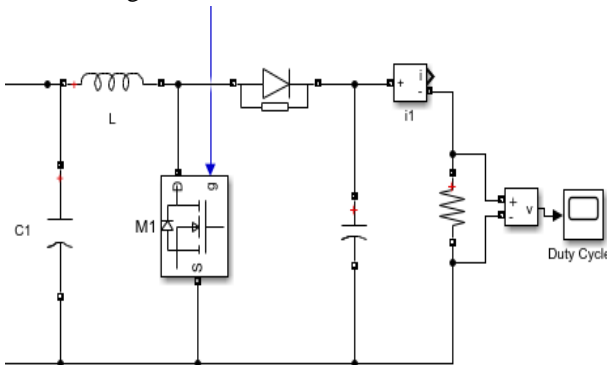

figure 6: DC-DC converter connected to PV module output and controlled by optimal controller.

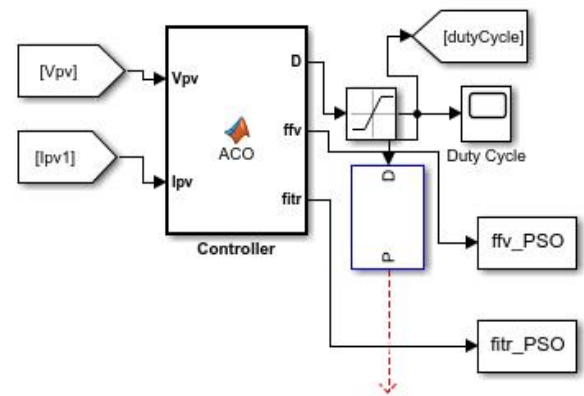

Figure 7: ACO controller for generating controlled pulses to DC DC converter.

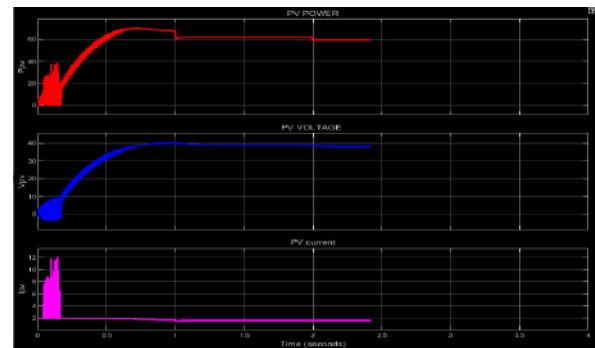

Figure 8: Power, Voltage and Current response at the output of PV array.

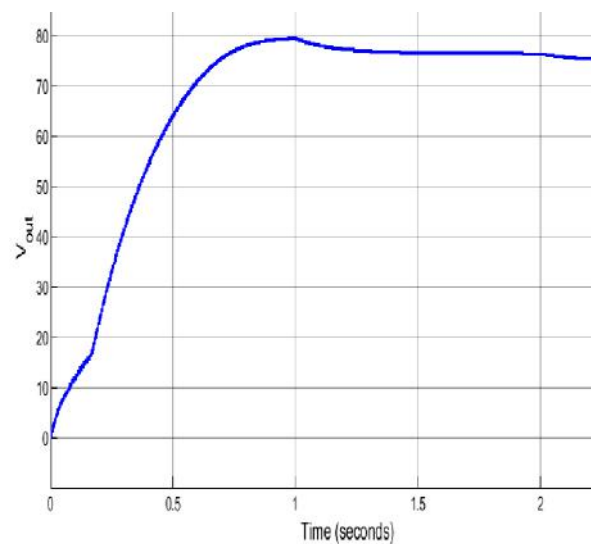

Figure 9 : Output voltage at the Load connected to DC-DC converter.

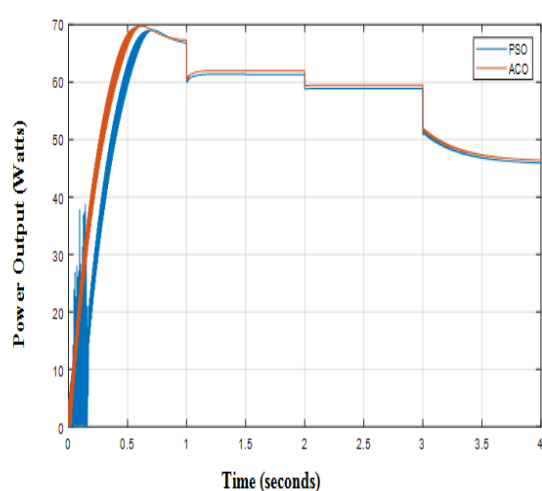

Figure 10: Dynamic response of optimum power output under different partial shading conditions.

Conclusion

Partial shade is one of the key problems that lowers the maximum power from the PV array. The literature lists a number of solutions to decrease these effects, including multilayer inverters, distributed MPPT, bypass diodes, PV module connectivity, and reconfiguration approaches. However, the primary focus of this study is on reconfiguration strategies for increasing maximum power under partial shade and mismatch issues. For these techniques, there are two different sorts of reconfiguration procedures: dynamic and static. The first two conclusions drawn from the review study and presented in this report are as follows. First off, dynamic optimization-based reconfiguration procedures are better to static techniques for reducing partial shading or any other issues. Second, it was determined that the Total-Cross-Tied (TCT) design with an ACO-based method was the best PV array configuration since it offered a well-organized optimisation and greater flexibility for reconfiguration methods. The reconfiguration strategies present new issues to the industries aiming to create greater maximum power. In the upcoming years, converting fixed PV facilities to reconfigurable ones might be a commercial objective.

References

1. A.G. Olab The 3rd international conference on sustainable energy and environmental protection SEEP 2009 – Guest Editor's Introduction Energy (2010)
2. B.R. David *et al.* Comparative environmental life cycle assessment of conventional energy storage system and innovative thermal energy storage system Int. J. Thermofluids (2021)
3. S. Abdo *et al.* Numerical study with eco-exergy analysis and sustainability assessment for a stand-alone nanofluid PVT/T Therm. Sci. Eng. Progress (2021)
4. K. Obaideen *et al.* On the contribution of solar energy to sustainable developments goals: case study on Mohammed bin Rashid Al Makhtoum Solar Park Int. J. Thermofluids (2021)
5. S. Mehranfar *et al.* Comparative assessment of innovative methods to improve solar chimney power plant efficiency Sustain. Energy Technol. Assess. (2022)
6. A.H. Alami *et al.* Novel and practical photovoltaic applications Therm. Sci. Eng. Progress (2022)
7. N. Khordehghah *et al.* Computational study and experimental validation of a solar photovoltaics and thermal technology Renewable Energy. (2019)
8. M. Venturelli *et al.* Comprehensive numerical model for the analysis of potential heat recovery solutions in a ceramic industry Int. J. Thermofluids (2021)
9. V. Guichet *et al.* Experimental investigation and analytical prediction of a multi-channel flat heat pipe thermal performance Int. J. Thermofluids (2020)