

PV Integrated UPFC

Authors: Nusheen Afza¹; Imran Khan²; Malik Rafi³

Lucknow, Uttar Pradesh, India^{1,2}; RR Institute of Modern Technology, Lucknow³

Email: nausheenafza8@gmail.com¹; pe.imran@gmail.com²; malik_rafi@rediffmail.com³

Abstract—This paper is based on integration of PV and unified power flow controller (UPFC) which will help us to reduce the harmful effects on environment due to generation of electricity through conventional sources of energy and it would also help us in compensation of reactive power which will lead to improvement in power quality and power factor. In this paper a UPFC is integrated to a PV connected grid which makes it environmental friendly and provides it long life with higher quality of power. The PV module is using MPPT controller so that we could extract maximum energy of the day and other than this we are using boost converter to step up the voltage level so that it could satisfy the need of power demand. At the output of boost converter we will get the dc and therefore we need to convert it into ac voltage and for this we have used inverter through which we will get ac voltage. Next step is to integrate UPFC so that reactive power could be compensated and we get high quality of power supply. To develop this model we have MATLAB/SIMULINK software and results obtained are eco-friendly as well as efficient and dynamic.

Index Terms— Integration, MATLAB, PV, reactive power, UPFC.

I INTRODUCTION

Due to the dwindling of reserves of fossil fuels and increase in global warming day by day alternative energies are gaining popularity. From all the alternative sources of energy available maximum attention is towards solar energy as it is available in abundance [1]. Solar cells and solar thermal are the two technologies that employ the solar energy [4]. A solar cell employs the phenomenon of photovoltaic effect. Because of several advantages of solar energy such as they are eco-friendly and do not add pollution to the environment therefore they are employed in number of applications such as solar water pumps, satellite power systems etc.

UPFC is a device that belongs to the family of FACTS which can be used to regulate number of parameters such as power factor, voltage, power or phase angle [7]. It helps in multi-tasking control on different parameters of the system as well as it also provides flexibility to the system [4]. When we incorporate this device into the transmission line then it helps to improve the quality of power by reactive power compensation which results in increasing flow of active power and thus makes the system more efficient.

Due to the several advantages of PV module and UPFC as described above we have integrated these devices to get environmental friendly and high quality of power which would also be less expensive as it is more efficient as compared to the power that we get through the conventional sources of energy [2][3]. In order to integrate these two powerful devices we took the help of MATLAB/SIMULINK software.

II PV MODULE

A power conversion unit of a PV generator system is a PV module. Solar insolation and cell temperature are the two factors on which characteristics of PV module is dependent. The characteristics of PV module are non-linear and therefore it was necessary to model the design and simulation of maximum power point tracking or a number of applications of a PV system. The figure shown below is the equivalent circuit of PV module.

In the below module by applying Krichoff's law we could obtain (I) which is the current flowing through the module.

Here I represents the current at the output terminals I_{ph} stands for the current of the photocell I_d stands for the current flowing through diode and I_{sh} stands for the current through the shunt resist

$$I_d = I_o \left[e^{\left(\frac{V}{nVT} \right)} - 1 \right]$$

Here I_0 stands for the reverse saturation current. The voltage due to thermal effects can be given as

$$V_t = kT/q$$

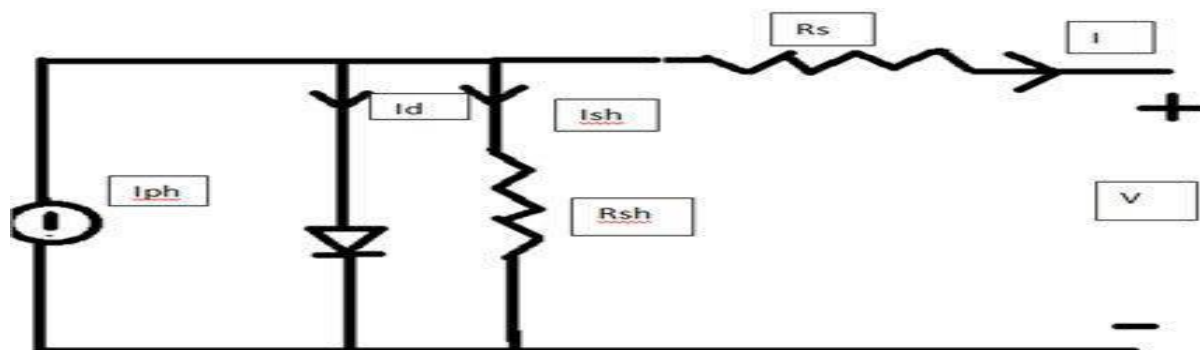

Figure1,PV MODULE The current flowing through shunt resistance can be given as

$$I_{sh} = V_j / R_{sh}$$

---[4]

By placing these above defines equations in equation 1 we get following equations

$$I = I_{ph} - I_0 \left\{ e^{\left(\frac{V + IR_s}{nV_t} \right)} - 1 \right\} - \left(\frac{V + IR_s}{R_{sh}} \right)$$

where I_{ph} is given as

$$I = N_p * I_{ph} - N_p * I_{sh} \left\{ e^{\left(\frac{q(V + IR_s)}{(N_s n k T)} \right)} - 1 \right\} - (V + IR_s) / R_{sh}$$

$$I_{ph} = [I_{sh} + K(T - 298)] * \left(\frac{G}{1000} \right)$$

[6]

The current through the module can be found out using

$$I_{module} = N_p * I_{cell} \text{ and } V_{module} = N_s * V_{cell}$$

[7]

[8]

Using these equations modeling of PV was done and results are as follows.

The output of so developed PV cell is shown in results as I_{PV} and V_{PV} [1]. The output of the PV cell is converted and displayed as V_{DC} and I_{DC} [2]. After this d.c component is removed out to get the pure a.c content which is represented in the figure 2 as I_{BOOST} and $V_{D.C}$.

The PV module is using MPPT which stands for maximum power point tracking so that maximum power can be tracked and converted into electricity which has helped in improving the power factor and hence the stability of the system. MPPT is able to track and capture maximum power and we have been able to built most efficient and eco-friendly system to generate power with long time and low losses as more and more reactive power can be transferred with least amount of reactive power and this also helps in increasing the efficiency of the system[5].

“ “

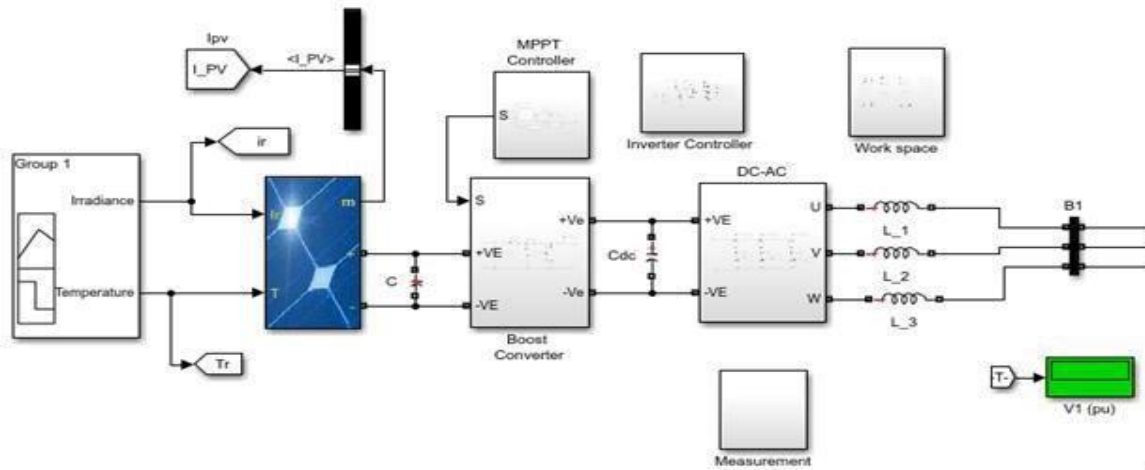

Figure 2, SOLAR SUPPLY SYSTEM

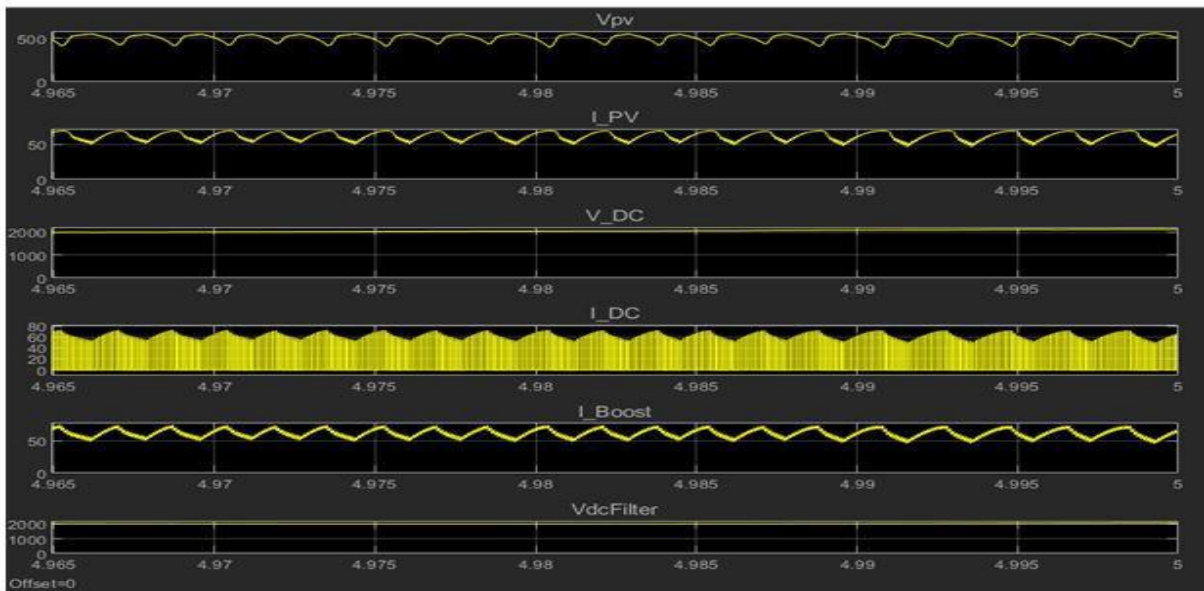

Figure 3 SOLAR POWER RESPONSE CURVES FOR VOLTAGE AND CURRENT

---III UPFC

UPFC is a device that belongs to the family of FACTS device. It is one of the most power device as it can control several parameters of the power system. It is a combination of static series synchronous compensator (SSSC) and static synchronous compensator (STATCOM). This device can perform the functions of thyristor controlled reactor (TCR), thyristor switched capacitor (TSC) or STATCOM and it can also perform functions by the combination of above defined controllers[9]. It helps in regulating the real as well as reactive power flow.

The UPFC as shown in figure consist of comprises of two branches. With the help of transformer voltage source converter injects a voltage in series while in shunt of the power system we connect a inverter at its input end[11]. An another inverter is connected in series with the ac transmission system. UPFC is able to exchange real power as it can inject voltage to the circuit of varying magnitude and phase angle.

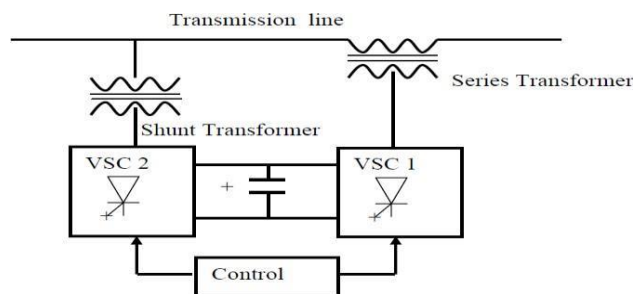

Figure 4, SCHEMATIC DIAGRAM OF UPFC

The UPFC at its shunt connected output provides reactive power support and satisfies the need of transmission line while at its series connected output it can control the real power transmission. UPFC is very versatile device as it can control the flow of real and reactive power independently[10].

IV POWER FLOW CONTROL OF UPFC

In order to control the flow of active and reactive power we have discussed control capability of UPFC. Series part of UPFC has more effects on power flow control as compared to shunt part of UPFC. Therefore more focus is kept towards the series part so as to control more and more flow of power. In UPFC this control capability can be done by two methods[9].

- a) By load control capability
- b) By remote control capability

When the angle of series voltage is varied and magnitude is kept constant then we could obtain an elliptical region. It was seen that the area under this region is the region that could be controlled through the series voltage and with the decrease or increase of injected voltage this controllable shifts.

The series part of UPFC has its own advantages. It is helpful in remote control capability as by changing the parameters of the series part it is capable of controlling power flow through the other lines[11]. Therefore both series and shunt part of UPFC has their own contribution in controlling power flow by the regulation of operating parameters respectively. In spite of their independent significance the conclusion can be drawn that the series part is more powerful as compared to shunt part of UPFC and controlling character of UPFC is more dependent on the series part. To have a better understanding

“of UPFC simulink model of UPFC is developed and results are as shown.

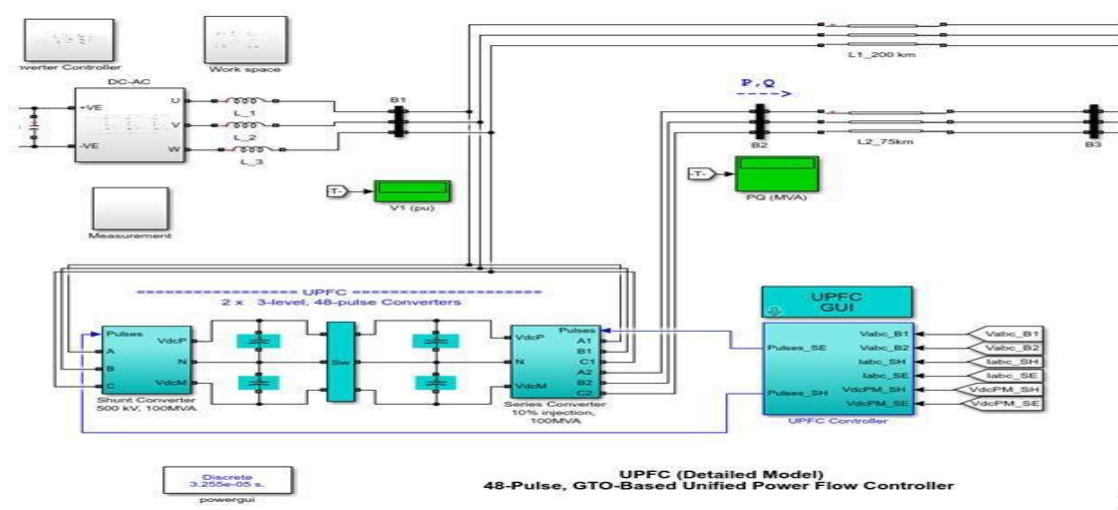

Figure 5, SIMULINK MODEL OF UPFC

“The above diagram is the next part of my simulink model which demonstrates UPFC as a FACTS device

connected to a 3 phase transmission line. It is capable of both series and shunt conversions. The pulse involved for controlling the series and shunt converters is controlled by UPFC controllers [4] [7]. By the use of feedback measurement the controller provides firing pulses to the shunt and series converter thus regulating the power quality. The following waveforms of figure 6 show that active and reactive power under the different conditions of load and irradiation the response is capable of tracking the reference power demand while maintaining low value of reactive power.

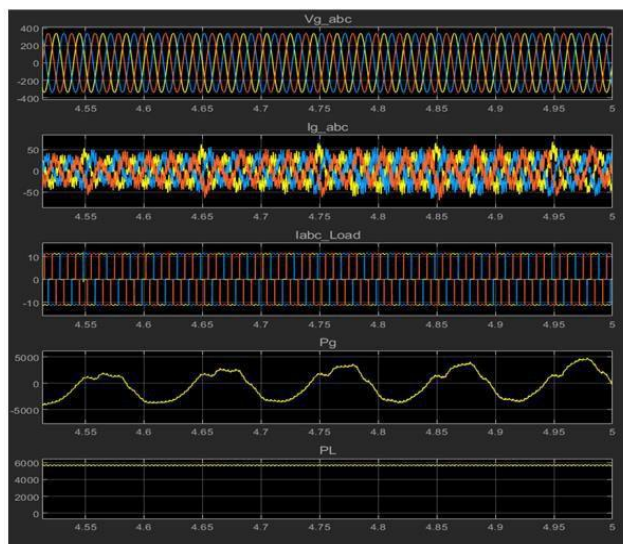

Figure 6, ACTIVE POWER VARIATION

V INTEGRATION OF PV AND UPFC

With the increase in demand of energy it is becoming imperative for us to think about the alternative sources of energy and the most easily available source of energy is solar energy that could be harnessed through PV cell and utilized to satisfy the ever-growing demand of ever-growing population. Therefore in my project I have integrated PV module to the UPFC [11].

We know that UPFC is capable of compensating reactive power and helps in improving the power quality and thus improving the efficiency of the system and PV helps to make the system more reliable in terms of life and also makes the system eco-friendly. It means that by we integrating these two systems then we can achieve two targets at the same time that is we will drift towards the non-conventional sources of energy and at the same time we have improved the power quality by reactive power compensation [3][2][7].

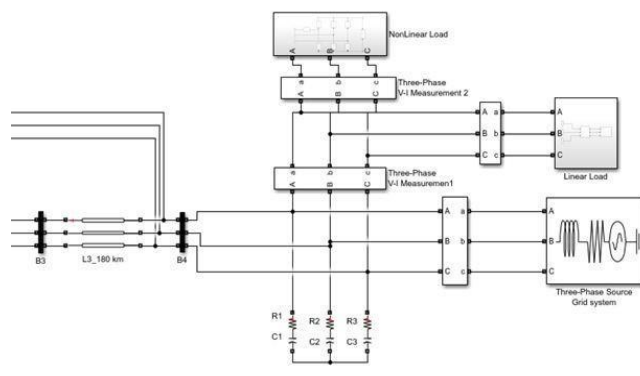

Figure 7, GRID CONNECTED TO BUS WITH SOLAR AND UPFC

“A unit which acts as an interfacing unit in my model is UPFC as it improves power factor and is also capable of providing reactive power as required by the transmission line. Another important role which is being performed by UPFC in my model is the exchange of solar energy source from load to grid [8][9]. If the power demands of load are more than the power that the source can supply then UPFC can satisfy this requirement and alter the flow of active and reactive power accordingly. In a similar way if the output that we get from solar energy

source is greater than the power demand of load then this excess power is delivered back so that it could be used at the time of need.

VI RESULTS

In my work a solar PV based grid connected model of the system is developed using the simulink under power quality regulations using one of the most powerful device of the family of FACTS and this device is UPFC which can control more than one parameters of the system simultaneously. The results that we have obtained on interfacing the UPFC to the PV connected grid are as follows.

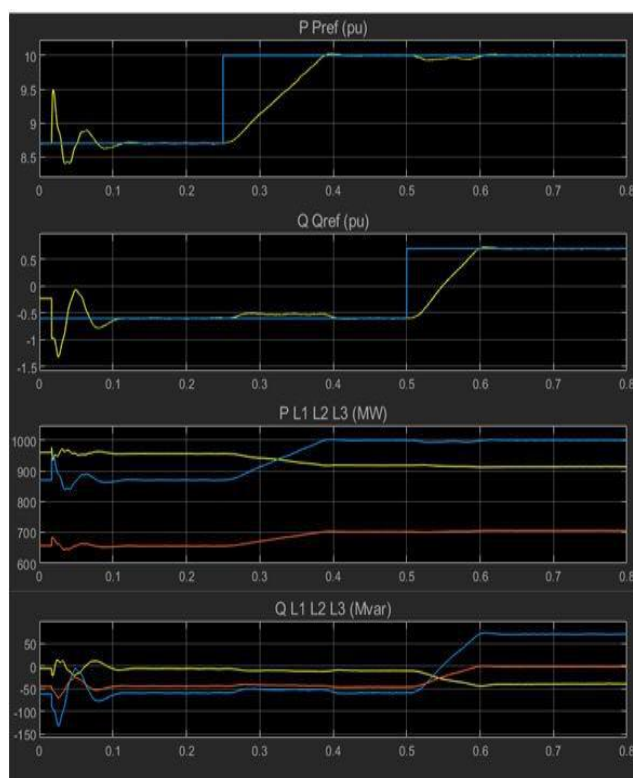

Figure 8, OUTPUT OF SIMULINK MODEL

From the waveforms that have been traced at the oscilloscope it can be observed that when UPFC is interfaced to a PV connected grid then also we could maintain the lowest reactive power values and use of PV also makes the system eco-friendly with its long life.

CONCLUSION

We know that demand of energy is increasing day by day with the increasing population and due to excessive use of non renewable sources of energy our environment is facing the problems of global warming, pollution and these resources cannot be replenished again so we need to take care of these resources. Considering all these reasons we need to shift our focus towards the other renewable sources of energy which are available in abundance. The best resource available to us is solar energy. When we interface the UPFC to the PV connected grid then and analyzed the model under the voltage, current and power at different buses then it was observed that reactive power is reduced significantly and power factor has been improved. In future we could make use of hybrid technology instead of solar energy to further improve the performance of the system.

REFERENCES

- [1] Mohammad Nazlum Islam Sarkar, Lasantha and Manoj Dutta, "Reactive Power Management in Renewable Rich Power Grids: A Review of Grid- Codes, Renewable Generators, Support Devices, Control Strategies and Optimization Algorithms," 2018 IEEE. Translations Volume 6, 2018.
- [2] Eklas Hossain, Mehmata Rida, Sanjeev Kumar and Intiaj Khan, "Analysis and Mitigation of Power Quality Issues in Distributed Generation Systems Using Custom Power Devices," 2017 IEEE. Translations, Volume XX, 2017.
- [3] Kavitha V and Dr. K. Subramaniam, "Investigation of Power Quality Issues and Its Solution for Distributed Power System," 2017 International Conference on Circuits Power and Computing Technologies [ICCPCT], 978-1- 5090-4967- 7/17/\$31.00 © 2017 IEEE.
- [4] Abubakar Siddiqui, Yonghai Xu, Waseem Aslam and Muhammad Rasheed, "A Comprehensive Study on FACTS Devices to Improve the Stability and Power Flow Capability in Power System," 2019 The Asia Power and Energy Engineering Conference, 978-1-7281-1590-0/19/\$31.00 ©2019 IEEE.
- [5] Shazma Khan, Balvinder Singh and Prachi Makhija, "International Conference on Innovations in Power and Advanced Computing Technologies [i-PACT2017]," 978-1-5090-5682-8 /17/\$31.00 ©2017 IEEE.
- [6] Rakesh Ranjan Sahoo and Madhu Singh, "Improved Mathematical Modelling for PV module using MATLAB/Simulink." 978-1-4673-8262-5/16/\$31.00_c 2016 IEEE.
- [7] R. Banu Priya and R. Ruban Raja, "Power Quality Improvement using UPFC with SOLAR CELLS by MPPT," International Journal of Advanced Research in Computer Engineering & Technology (IJARCET) Volume 3 Issue 7, July 2014.
- [8] Rinchin W. Mosobi, Toko chichi and Sarsing Gao, "Modeling and Power Quality Analysis of Integrated Renewable Energy System," 978-1-4799- 5141-3/14/\$31.00©2014 IEEE.
- [9] Xianzhong Duan and Yifang Luo, "Power Flow Control With FACTS Devices," 0-7803-6420-1/00/\$10.00 (c) 2022 IEEE.